

# THE CHARGE STATE BREEDER BRIC: STATUS REPORT

V. Variale, V. Valentino, INFN sezione di Bari, Bari, Italy

A. Boggia, G. Brautti, T. Clauser, A. Rainò, Dipartimento di fisica Università di Bari e INFN sezione di Bari, Bari, Italy

Y. Boimelshtein, P. Logatchov, B. Skarbo, M. Tiunov, BINP, Novosibirsk, Russia

## Abstract

The "charge state breeder" BRIC (BREeding Ion Charge) is in construction at the INFN section of Bari (Italy). It is based on EBIS scheme and it is designed to accept Radioactive Ion Beam (RIB) with charge state +1 in a slow injection mode. It will be tested at ISOL/TS facility of LNL (Italy). Furthermore, it could be considered also as a technical solution of the charge breeder of the SPES project under study also at the LNL.

The new feature of BRIC, with respect to the classical EBIS, is given by the insertion, in the ion drift chamber, of a RF - Quadrupole aiming to filtering the unwanted masses and then making a more efficient containment of the wanted ions. In this paper, the charge breeder BRIC status and the related construction problems with the first test results will be reported.

## 1 INTRODUCTION

The increasing interest in nuclear astrophysics and nuclear structure studies has led, in the world, many laboratories to project and build ISOL facilities for the production of RIB accelerated up to several MeV/u [1]. Among them there is the SPES project of Legnaro National Laboratory (LNL) (Padua) that it is in advanced phase of study. In the framework of SPES, our INFN group, in Bari, is involved in the development and testing of a "charge state breeder" device based on an EBIS source type: BRIC [2]. In the SPES project, the foreseen accelerated radioactive atoms will have, with the most probability, masses lying in the range 80-150 a.m.u then the using of a charge state breeding technique will give a more efficient RIB post-acceleration. For this reason the BRIC device test could be of big interest for SPES.

In this paper the status report of the BRIC experiment with the main construction problems faced up to now will be presented and shortly discussed with the first tests.

## 2 BRIC EXPERIMENT

The Breeding Ion Charge (BRIC) experiment, funded by the INFN agency, will test an EBIS slow injection breeding scheme[3]. As mentioned before, in BRIC the EBIS design has been modified by adding, in the region of the drift tubes, an RF quadrupole field with the aim to increase the breeding containment efficiency. Preliminary simulations have been in order to verify that the typical selective rf containment is not lost by the effect of the

simultaneous presence of rf, solenoid and electron beam space charge fields on the ions.

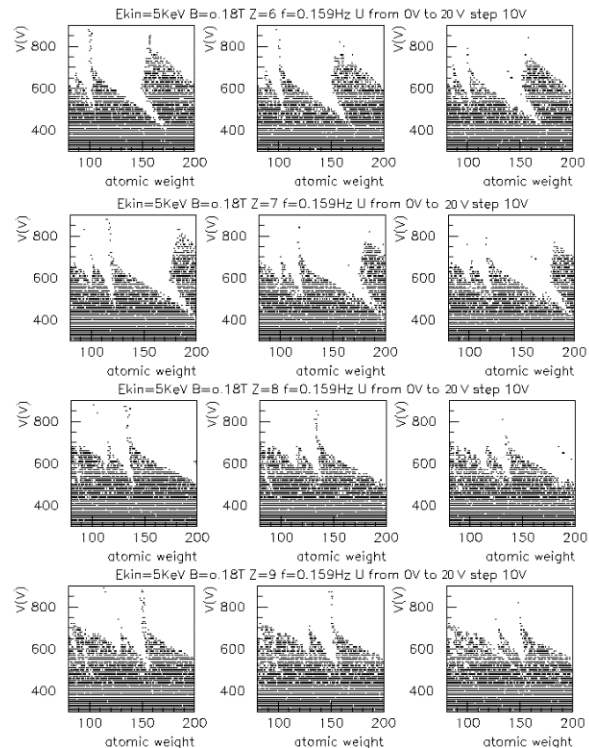

Figure 1: Stability regions for ion masses in the region 80 – 200 Amu in function of the rf amplitude, V, for different ion charge state and DC amplitudes, U. The space charge term is obtained by  $I_e = 100$  mA,  $\nu=159$  kHz and  $B=0.18$  T.

To this purpose a code that simulates the ion motion inside the rf quadrupole field in the presence of the electron beam space charge and solenoid field has been developed. Furthermore, to make the simulations more close to the real situation the ion charge state evolution and the space charge compensation to the electron beam well potential depth, due to ionisation process, have been implemented in the code more recently [4].

From the simulation results of fig. 1, it can be seen that although the presence of the magnetic field and the space charge effect, stable zones in function of the rf parameters (as the DC amplitudes U and rf amplitudes V) can be still obtained. In those figures, the ion stable motion conditions are indicated by black dots. The formation of stable ion motion zones, then, indicate that the adding of

the rf quadrupole field for selective containment could be helpful to increase the production efficiency of radioactive ions with desired charge state for re-acceleration.

The BRIC set-up assembly without the solenoid, needed for electron beam focusing and transport, is shown in fig. 2. It is practically an EBIS except for the rf electrodes inside the drift tube chambers that gives the rf quadrupole field and also the longitudinal potential well.

The detailed design of the device has been already presented in ref. [3]. Here, for sake of clarity, we will describe again, shortly, the device features.

The BRIC electron gun (see fig. 2) does not have the usual Pierce focusing electrode. The electron beam focusing will be realized only by the increasing axial magnetic field given by the solenoid. In this way, the scallopes produced in the electron beam flow due to unbalance between the electric and magnetic focusing forces will be reduced [5,6]. This choice is due to relatively low solenoid magnetic field that can be reached with the funds available for this experiment. With the axial magnetic field obtainable, the designed current density (less than 10 A/cm<sup>2</sup>) can be reached by increasing of a factor 2 the perveance of the electron gun through the removal of the Pierce electrode [5]. The gun cathode is of dispenser type. It has 5 mm of diameter and is capable of providing a current up to 1.5 A. The electron beam output energy can be raised up to 10-15 keV. The transverse dimensions of the beam are maintained practically constant (immersed flow configuration) along the drift tube up to the collector by the axial magnetic field of the solenoids placed on the ion chamber. Actually, the solenoids are made of coils designed in an appropriate way to be mounted together to form a solenoid [5]. This technique, which has been successfully used by the BINP institute of Novosibirsk to construct the solenoid for the E-Cooling system of GSI, can reach a field precision of 10<sup>-5</sup>.

The collector (see fig. 2) has, at the end, an ion extraction electrode which has also the task to repel the electrons by opening them further and focus the ions at the exit hole where there is another electrode that can be used to give the start and stop signal for the Time Of Flight (TOF) system, for charge state analysis, that will be placed at the end of the BRIC to analyse the ion charge states.

An EBIS ion chamber is usually designed to accommodate the drift tubes with the aim to give the barrier potential for the longitudinal ion trapping. In our case the cylinder shaped rf electrodes giving the RF-Quadrupole field, being separated in 4 sectors, will create also the longitudinal potential well. All the feed troughs

for DC voltage and RF power supply, diagnostics and so on, have been inserted in the central zone of the chamber (see fig. 2). For this reason, the solenoid that generates the longitudinal magnetic field for all ion chamber (110 cm length) is divided in 2 parts (see fig. 4). The current, in the winding coils forming the solenoid, can be greater than 130 A and a maximum field of about 2 k Gauss could be obtained on the axis with this current. The chosen field value on the axis, compatible with the fund obtained by INFN for the experiment, permits to obtain a value of J (electron beam current density) less than 10 A/cm<sup>2</sup>. Notice that, for this current density (following the SPES project requirements), if an ion mass of about 100 a.m.u. and a charge state of 10 (charge over mass ratio = 1/10) is considered, a “breeding parameter” [7]:

$$J \cdot \tau_c \approx 3 \div 4 \text{ [A} \cdot \text{sec/cm}^2\text{]}$$

can be obtained by using the Lotz formula [8] as ionisation cross section. For a charge state of 10, This value gives confinement times of about 300 ms, a large value for radioactive ions. However, it is enough to test the charge state breeding efficiency increase obtainable with the adding of rf quadrupole field which is the main purpose of the BRIC experiment. In fact, in this case, we can content ourselves to a lower charge state. An improvement of BRIC to increase J will be, of course, in order in the case the SPES facility will use it as charge breeder.

### 3 EXPERIMENT STATUS AND CONCLUSIONS

BRIC experiment will be carried out in two stages. The first one the test of BRIC device as a stand alone highly charge state ion source, in the latter, the same device will be used as charge breeder of an ISOL facility based on the CN accelerator located at LNL called ISOL-T/S. Now we are involved in the first stage. Up to now, all the part of the BRIC device have been built except the coils that will form the solenoids. However, all the coils are in an advanced phase of construction and for the end of September the BRIC solenoid will be ready.

In fig. 3, one of the already built coils is shown. From that figure it can be seen, in the upper part, 2 kinds of metallic wings needed to align the coils to the beam axis and so minimize the magnetic field error. The main problem, for the coils alignment with respect to the electron beam axis, is given by the presence of rf feed through in the middle of ion drift chamber that prevents to it the possibility of entering, once assembled, the solenoid.

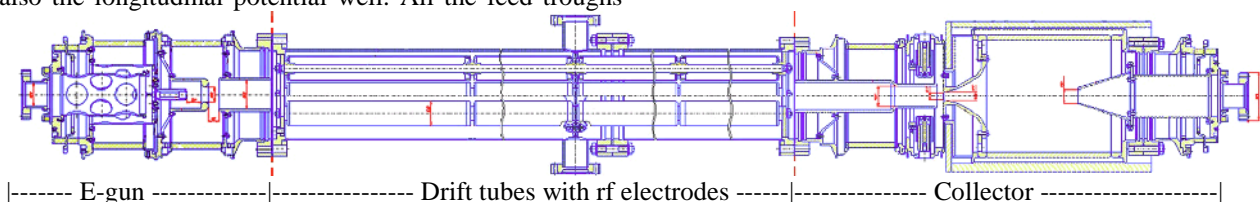

Figure 2: BRIC set-up assembly design, without the solenoids for the electron beam focusing.

On the other hand, it is very difficult to align the solenoid



Figure 3: A built coil that will form, together to the others 19, the BRIC solenoid.

coils with the ion drift chamber inside. For this reason, two different supports have been designed, the first one for the complex: gun, ion drift chamber, collector and the latter only for the solenoid (see fig.4). In this way, the solenoid will be assembled and aligned on its support separately and once fixed the right coil positions on the support, the solenoid will be disassembled and the reassembled around the ion drift chamber.

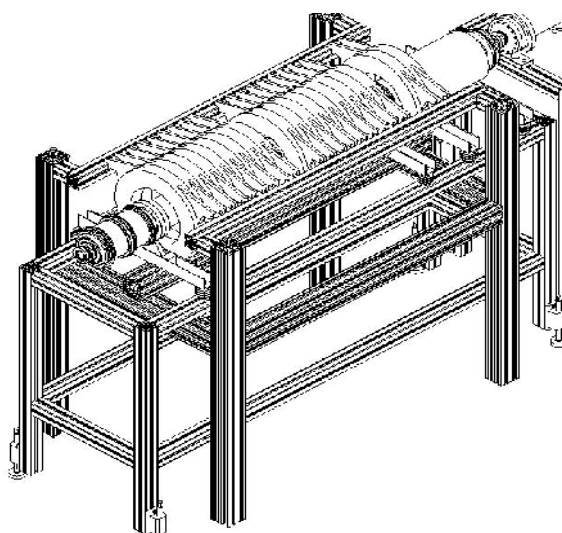

Figure 4: BRIC and Solenoid support design.

The coil alignment will be realised through a mirror attached on a small permanent magnet dipole free to rotate inside the solenoid field. A laser beam impinging on the mirror will be reflected outside the axis in presence of field errors.

Although the solenoid coils, as already mentioned, are still not ready, all the parts of the BRIC device have been mounted, as shown in fig.5, to test the device vacuum tight, the electron gun, the collector and the TOF system.

The construction of 4 home made coils ( $B_{max} = 250$  G) has allowed the electron beam transport from the electron gun to the collector at low power. The electron beam current measured at the collector has been of 16 mA

corresponding to a recovery efficiency of 80%. In the test, the cathode potential has been put to  $-500$  V and the extraction electrode to  $+500$  V, then an electron gun Perveance of  $0.65 \mu P$  has been evaluated.



Figure 5: Low power test for the electron beam transport in BRIC.

The ion extraction, from the collector to test the TOF system, is now underway. From fig. 5, it can be seen that the TOF system is composed of 2 parts. In the first part is located a drift tube with deflecting plates for correction that will be removed in the second stage of the experiment. That will allow the insertion of a deflecting tube for the injection of the ions  $+1$  coming from the ISOL/TS facility.

Up to now the high vacuum reached in the BRIC chamber has been about  $8 \times 10^{-9}$  mbar, not so high. However, this not so good value depends on the presence of PVC in our home made coils which did not tolerate the heating of the chamber for more than  $100^\circ C$ .

In conclusion, we think to finish these preliminary tests for the end of September when all the coils will arrive. In October we will start with the solenoid mounting and alignment to the LNL. Then for the end of the year the experiment will start.

#### 4 REFERENCES

- [1] SPES Project study, LNL-INFN (REP), 145/99.
- [2] G. Brautti et al., 'BRIC: An EBIS design for charge state Breeding in RIB', EBIS/T 2000, Upton, New York.
- [3] U. Koster et al., Rev. Sci. Instrum., 69 (1998)1316.
- [4] V. Variale et al., 'BRICTEST: A Code For charge Breeding Simulations', EPAC2002, Paris, June2002.
- [5] A. Boggia et al., 'An EBIS For Charge State Breeding in the SPES Project', in pub. On the Proceedings of the Conference HIAT 2001 (New Delhy) India.
- [6] V. G. Abdul'manov et al., 'Electron-Optic System of the multicharged Ion Source (MIS-1)', EBIS/T 2000, Upton, New York.
- [7] M. C. Vella, Nucl. Instrum Meth., 187(1981)313.
- [8] W. Lotz, Z. Phys. 206 (1967) 205.