

STABILITY IMPROVEMENT OF THE SPRING-8 LINAC

S. Suzuki[†], T. Asaka, H. Dewa, T. Kobayashi, A. Mizuno,
T. Taniuchi, H. Tomizawa, K. Yanagida and H. Hanaki,
SPRING-8/JASRI, Mikaduki, Hyogo, Japan

Abstract

The SPRING-8 linac has been improved the beam stability by means of reinforcement of monitor systems, reduction of RF fluctuation, and energy compensation: A BPM system adopting a logarithmic detector has been developed and its VME control system employing shared memories for fast data acquisition has been completed in this spring. A quasi non-destructive profile monitor using OTR was installed in a 1-GeV chicane section to observe the beam energy and energy spread before an Energy Compression System (ECS). A beam trigger pulse and a master RF signal (2856 MHz) were synchronized to stabilize beam bunches. The ECS was installed in 2000 to compensate the energy variation and reduce the energy spread due to beam loading. As a result, a beam energy fluctuation of 0.01 % (rms) has been achieved and reduced energy spread realized the high-current injection into the 8-GeV booster synchrotron.

1 INTRODUCTION

The SPRING-8 accelerator complex is composed of a 1-GeV electron linac, an 8-GeV booster synchrotron and an 8-GeV storage ring. The linac injects electron beams into the booster synchrotron and also into the 1.5-GeV storage ring NEWSUBARU which was completed in the SPRING-8 site in 1998 of the Himeji Institute of Technology.

The linac has been operated since August 1996, when beam commissioning began, and until the early summer of 2002 has not encountered any significant problem. The cumulative operation hours from the beginning of the user service operation till this summer has reached about 23,000 hours.

The instability of the linac's beam energy has been investigated since 1997. As a result, we reduced variations in the RF power and phase by stabilizing the temperature drift of the atmosphere and cooling water and by readjusting the de-Qing efficiency of klystron modulators in order to reduce the PFN voltage fluctuation. Finally, a minimum energy fluctuation of 0.03% (rms) was achieved and the reappearance of the injection current was considerably improved [1].

Following the first refinement mentioned above, we aimed to make the linac more stable and more reliable by improving an RF system and reinforcing beam monitor systems. As a result, a short-term energy stability of a 1-ns beam, for example, reached 0.01% rms and a beam energy spread was reduced. At moment a diagnosis of the

linac comes easier and automatic control programs such as feedback control are also under development. The upgrade programs has been intensively carried out and will be completed in this fiscal year.

2 DETAILS OF IMPROVEMENT

After the first stabilization mentioned above, the following programs have been performed to improve the beam stability:

- Renewal of control system, 2000
- Installation of ECS, 2000
- Installation of synchronous reference generator, 2001
- Upgrade of booster klystron, 2001
- Reinforcement of beam monitor, 2001-2002
- Phase stabilization of drive line, 2002
- Optimisation of RF power for pre-bunchers, 2002

Details of important programs are described in the following sections.

2.1 Synchronous RF reference generator

An electron-gun-trigger signal is produced by dividing a storage ring's RF reference of 508.58 MHz. A beam pulse from the gun, however, was not synchronous to a linac's reference of 2856 MHz, since the frequency of 2856 MHz is not an integral multiple of 508.58 MHz. Therefore, a bunch number of a beam holding 1-ns pulse width, for example, is two or three according to a beam timing asynchronous to the 2856-MHz reference. Consequently, the charge amount in each bunch was not stable and thus beam loading varied bunch-by-bunch. This random variation finally caused shot-by-shot fluctuation of the beam energy center.

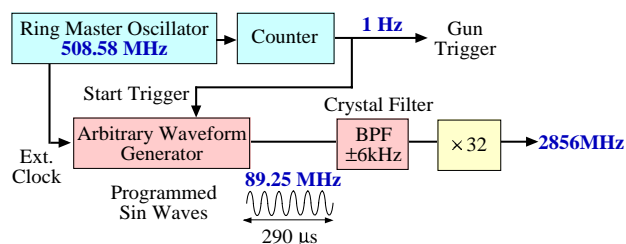

Fig. 1 Block diagram of RF reference generator.

In order to reduce the energy fluctuation, a new method was invented to realize complete synchronization of the beam trigger and the linac RF as shown in Fig. 1 [2]: A master oscillator generates a reference signal of 508.58 MHz. A beam trigger of 1 Hz is produced by counting the 508.58-MHz reference. Sinusoidal waves of 89.25 MHz

[†]shin@spring8.or.jp

with a duration of 290 μ s, whose frequency is 2856 MHz divided by 32, are programmed in an arbitrary waveform generator. The waveform data were automatically programmed by sampling ideal 89.25-MHz sinusoidal waves at the reference frequency of 508.58 MHz. The 1-Hz beam trigger starts the generator to oscillate by referring to the external 508.58-MHz clock, and thus an 89.25-MHz burst signal is generated which synchronizes with the 508.58-MHz reference. This intermediate signal is filtered by a high-Q crystal filter with a bandwidth of 12 kHz to reduce phase noises. Finally, the filtered signal is multiplied by 32 to generate the 2856 MHz reference. Note that this RF reference signal is not CW but burst waves.

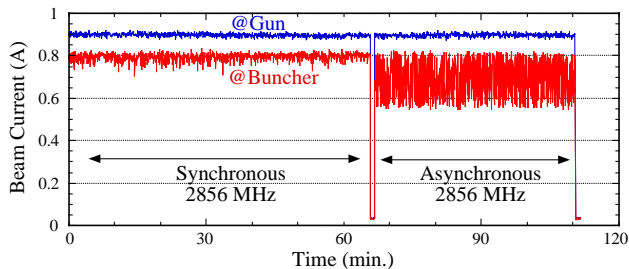

Fig.2 Stability of single-bunched beam

The electron gun can generate a 250-ps beam. The buncher compresses a part of the beam, and then forms a single bunch. Figure 2 shows an example of beam current measurement in single bunch acceleration. The fluctuation of current observed when using the previous asynchronous system, through it does not appear in the new synchronous system. This measurement clearly proves that the new 2856-MHz reference signal synchronizes with the beam trigger.

2.2 Upgrade of booster klystron

Before 2001, one 7-MW klystron, called booster klystron, fed an RF power to a buncher section and driven twelve 80-MW klystrons. A modulator for the 7-MW klystron was manufactured in the early stage of development of SPring-8, therefore it is lacking in reliability compared with modulators for the 80-MW klystrons. Moreover, this unique modulator spoiled maintainability of the RF power source, since it could not share spare components with the 80-MW klystrons' modulators.

The first 80-MW klystron has fed an RF power of 40 or 50 MW only to the first regular accelerator column and left the sufficient margin of its output power. Therefore the RF output power branched to the buncher section and a drive line for the other 80-MW klystrons as shown in Fig.3, thus the 7-MW klystron amplifier was excluded in the summer of 2001.

Consequently, all the klystron systems were unified into Toshiba E3712 and the maintainability was improved.

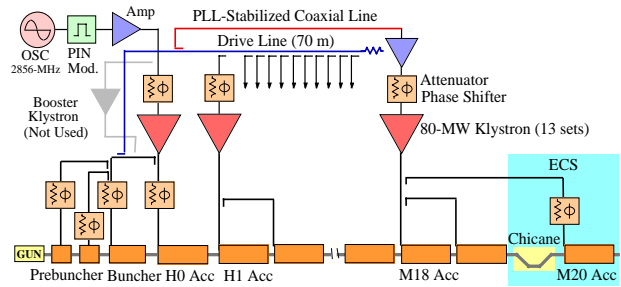

Fig.3 Diagram of improved RF

2.3 Installation of ECS

In order to narrow the beam energy spread caused by beam loading and consequently to extend the upper limit of the injection current, a conventional type energy compression system (ECS) was introduced [3].

The terminal beam energy is sensitive to the RF phase, which the beam bunches meet in an accelerator column of the ECS, since the phase value is around zero where the field gradient referring to a phase is the maximum. Hence, the RF phase has to be strictly regulated to stabilize the energy of the beam compensated by the ECS. Reducing the phase fluctuation of the ECS's klystron, a phase-locked-loop technique was applied to an independent drive system for the klystron, as shown in Fig. 3.

It was observed that the ECS compressed the full energy spread of the 40-ns beam at high current of 350 mA, from 3.6 % to 1.4 % which is narrower than the energy acceptance of the booster synchrotron.

The ECS can also reduce the energy fluctuation according to the same principle. For example, the ECS suppressed the energy variation of 0.06% (rms) down to 0.01% (rms) for the 1-ns beam acceleration when the synchronous generator transmitted the reference RF. Thus the ECS is useful to maintain the shot-by-shot and long-term beam energy stability.

2.4 Stabilization of drive line

The drive line for exiting twelve klystrons is a 70-m long waveguide filled with nitrogen gas. As shown in Fig. 4(a), a phase drift of 18.5 degrees was observed at the terminal of the waveguide. This phase variation clearly caused the beam energy variation, the terminal beam energy, however, was stabilized by the ECS. Although correlations among the phase variation, room temperature, and a nitrogen gas pressure were observed, an original source of the variation has not been found yet.

Therefore the gas pressure control was primarily tried to reduce the phase drift. Figure 4 indicates that the gas pressure drift was compressed from 3 to 0.21 kPa. On the contrary, the RF phase variation was reduced from 18.5 to 4.8 degrees. This fact indicates that the true origin still affects the phase.

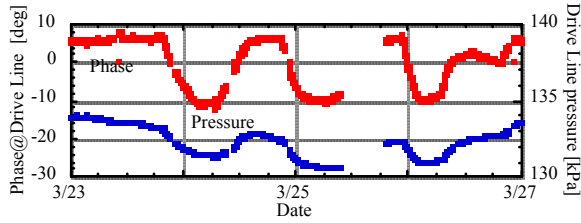

Fig. 4(a) N₂-gas pressure and driveline phase drift (Feedback off)

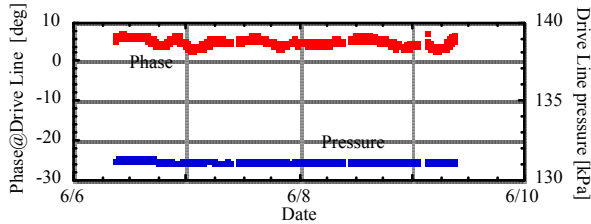

Fig. 4(b) N₂-gas pressure and driveline phase drift (Feedback on)

2.5 Reinforcement of beam monitor

For a diagnosis of an electron beam or feedback beam control, non-destructive beam monitors such as BPM or energy monitor are useful in practice.

A BPM system employing a strip-line type pickup and a logarithmic detection method has been developed and was installed in 2001. The system has a dynamic range wider than 45 dB and a maximum position resolution of few tens of micron meters (2σ). A data acquisition system was required to process data of all the channels synchronizing with 60-Hz beam pulses to represent a one-pass beam orbit of the linac. Therefore, a shared memory method was introduced for synchronized data acquisition by several VMEs, as shown in Fig. 5[4]. The data acquisition system is almost completed and an automatic beam steering program has been made and it is currently undergoing testing. The shared memory network will function soon.

It is very important in practice early to detect troubles of accelerator equipments by monitoring the beam energy and energy distribution before being compensated by the ECS. For this reason, a beam-penetration type thin foil screen monitor was introduced in the center of the 1-GeV chicane where the energy dispersion is 1 m. The screen is a 12.5- μm thick Kapton film coated with 0.4- μm aluminium. A CCD camera captures OTR (Optical Transition Radiation) emitted by beam irradiations on the screen. The captured beam images are analyzed to determine the beam energy and its spread. This analysis is executed automatically and the results are accumulated in the database. The 1-GeV beam has an emittance of $5 \times 10^{-8} \pi$ mrad and the screen increases it to $5 \times 10^{-7} \pi$ mrad. This emittance growth is negligible. Therefore, the screen is inserted to monitor the energy during beam injection into the synchrotrons.

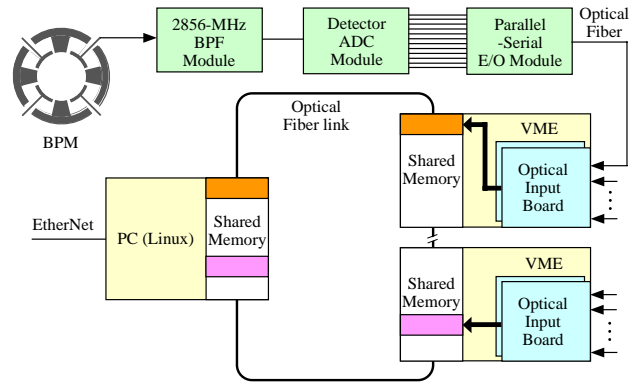

Fig.5 Block diagram of BPM data acquisition system

3 ACKNOWLEDGEMENT

The synchronous RF reference generator was invented and developed by staffs of the storage-ring's RF group. The control group developed the BPM data acquisition system. Staffs of SES helped us to stabilize the drive line. We are grateful to them for their very large contribution to the linac's stability improvement.

4 REFERENCES

- [1] T. Asaka, H. Hanaki, T. Hori, T. Kobayashi, A. Mizuno, H. Sakaki, S. Suzuki, T. Taniuchi, K. Yanagida, H. Yokomizo, H. Yoshikawa: "Stabilization of the rf system at SPring-8 linac": Nucl. Inst. Meth. A488(2002)26-41
- [2] K. Kawashima et al., "New synchronization method of arbitrary different radio frequencies in accelerators", Phys. Rev. ST Accel. Beams 4, 082001(2001)
- [3] T. Asaka, H. Dewa, H. Hanaki, T. Kobayashi, A. Mizuno, S. Suzuki, T. Taniuchi, H. Tomizawa, K. Yanagida: "Performance of the Energy Compression System at the SPring-8 Linac", proceedings of EPAC 2002, Paris, France
- [4] K. Yanagida, T. Asaka, H. Dewa, T. Fukui, H. Hanaki, T. Kobayashi, T. Masuda, A. Mizuno, S. Suzuki, R. Tanaka, T. Taniuchi, H. Tomizawa and A. Yamashita: "Installation of The SPring-8 Linac BPM System": in this conference.