

A NEW TECHNIQUE FOR HIGH PRECISION ALIGNMENT
OF LINEAR ACCELERATORS

Hans D. Betz

Kansas State University*
Manhattan, Kansas
66502

This paper presents a new alignment and surveillance technique of high accuracy. Utilizing asymmetrical effects produced in the light distribution of a laser beam, this new method shows remarkable advantages: any number of object-points can be placed on a straight line and displacements of 0.01 mm, for example, are detectable in distances from zero to several kilometers, provided that the disturbing influences of turbulence and refraction in the atmosphere are eliminated. The setup is very simple, and all targets representing object-points are identical. Therefore, the equipment to be used, including the detection unit, is independent of all distances involved. The alignment can be done simultaneously in two dimensions, both visually and fully automated. Special applications to linear accelerators with lengths up to several kilometers will be discussed and compared with conventional and existing alignment techniques. Limitations and distorting effects will also be considered.

*Former address: University of Heidelberg

Introduction

Alignment of accelerators has become a serious problem, because both the demands for accuracy and the lengths of the accelerators are steadily increasing. The conventional alignment techniques where cross-wires or fiducial marks are observed by means of a telescope¹, can no longer meet all requirements. New methods are desired in order to detect displacements of a target at any distance within a neglectable time, fully automated and without the help of qualified specialists.

Fortunately, coherent laser light is well suited for such new techniques exceeding the "classical" ones with respect to accuracy and practicality. Several methods using laser light are already in use, but all of them are based on the maximum principle, i.e. aligning means to find the maximum in the light distribution of a laser beam. The new technique, however, the asymmetry method to be described in this paper, is based on the minimum principle. Therefore, it seems to be appropriate

to discuss briefly the main features of the maximum methods.

Maximum Method

It is rather simple to stabilize the fundamental frequency of a laser (TEM-00-mode, circular light spot) and therefore an optical axis can be defined by the center of the beam. At any distance this axis is represented by an absolute maximum of intensity in the beam cross section, detectable with a certain error Δx . Although a laser radiates a very bunched beam, the divergence is not neglectable and at a distance of 1 km the beam diameter will be approximately 1 m. Because of both technical reasons and also the accuracy, such a spot size is not desirable.

It is advantageous to place a telescope behind the laser, focused to infinity. Then, in the example mentioned above, the beam diameter can be reduced from 1 m to about 10 cm. The quality of the optical system has to be perfect enough to preserve the coherent wave fronts so that no disturbing diffraction occurs. Such telescopes are already available and, since no focus control is necessary, they don't have moving parts. In order to detect the central maximum of intensity, various devices have been developed, such as quadrant detectors or centering units. Whatever the method of detection may be, assuming most favorable conditions, the accuracy with which the axis can be determined, is given by the relation:

$$(1) \quad \Delta x = \frac{h}{4} \cdot \frac{\Delta I}{I_m}$$

ΔI represents the smallest detectable deviation of intensity, I_m is the maximum intensity in the center of the beam, h is the beam width and Δx the resulting uncertainty of the measured center. Let us assume, for instance, a realistic intensity resolution of $\Delta I/I_m = 8\%$ and a beam width of $h=5$ cm, then the minimum error of the detected center is $\Delta x = \pm 1$ mm. The same relation refers to the second dimension (y-axis, perpendicular to the x-axis in the plane of observation).

A disadvantage of this maximum method is that the beam width is rather large in the whole system, especially if a telescope is used, which necessarily enlarges the beam at the beginning of the system to about half the value of the optimized beam diameter at the end of the system. Therefore, for a given intensity resolution, the accuracy can only be improved if the beam width is reduced. It seems to be efficient to introduce a focusing device into the beam. For short systems with a length of a few meters, this can be done with normal glass lenses, whereas Fresnel lenses could be employed in long systems. If such a zone plate is illuminated by coherent light (laser light), a line focus is produced. Using zone plates with central symmetry, a point focus can be obtained. The focal length of such a lens is dependant on the size of the zones, the sharpness of the focus is determined by the total width D of the lens. Let λ be the wave length of the laser light, then the angular width of the focus is given by λ/D . Inserting this result in equation (1) the accuracy with which the axis of the system can be detected at a distance equal to the focal length L , becomes

$$\frac{\Delta x}{L} = \frac{\lambda}{4D} \frac{\Delta I}{I_m}$$

With $D=10$ cm, $\lambda=6328 \text{ \AA}$ (red light) and $\Delta I/I_m=8\%$ an accuracy of 10^{-7} rad (0.02 seconds of arc) is obtainable. A maximum method like this is in use for the alignment system of the two-mile linear accelerator at Stanford².

The maximum method, however, has another disadvantage. The system is of little flexibility and Fresnel zone plates are difficult to manufacture. The optical axis of the system can only be determined in, or very close to the focus at the distance L . In order to align at another distance, the lens has to be replaced by another one with another focal length. That is a handicap of all maximum methods, because a sharp maximum of intensity can only be produced locally, according to the principal laws of optics. Therefore, we may ask if there is an alternative to the way of defining the axis by means of a maximum. This is the case because of the excellent coherence of the laser light which enables us to control both the phase and the amplitude of the light resulting in effective diffraction patterns.

The Asymmetry Method

Definition of the optical axis

A promising possibility is to define the axis of the system by means of an absolute minimum of intensity. This means that we need a laser beam in the center of which there is no light over the entire length of the system where alignment will take place. It will be shown that using an absolute

minimum, the disadvantages of the maximum method mentioned above, are becoming irrelevant and neither the beam width nor the distance in which an object has to be aligned are of decisive interest. At first, however, two possibilities are demonstrated for the production of a "zero-intensity line" within a laser beam:

- 1) The geometry of the laser-resonator can be changed so that certain higher normal modes of transversal vibrations are emitted, showing the desired central minimum.
- 2) The laser radiates the fundamental transverse mode and an external phase shifting plate is placed into the beam, producing the minimum by means of diffraction.

It is a very old idea to produce zero lines of intensity by interfering beams of opposite phase and many authors have studied this effect, especially in connection with general considerations about the symmetry of diffraction patterns³⁻⁶. Some more applications--before the invention of the laser--are given by H. Wolter⁷ and can be found analogously in the radio wave techniques

The possibilities 1) and 2) can be performed so that both one and two perpendicular planes of intensity zero are produced, separating maximums of intensity. In the second case, the axis of the system is represented by the intersection of the two planes and the beam cross-section shows two dark lines, so to speak, the beam is carrying its own "cross-wires" all over the path.

It is rather inconvenient to produce those "cross-wires" by means of method 1), especially because of the instability of the higher modes and the increased divergence of these modes. Method 2), however, can easily be used; the phase shifting plate consists of four parallel and homogeneous layers, the thicknesses of which have to be chosen so that the resulting phases of adjacent parts of the beam are differing by $\lambda/2$. Those plates can be made without difficulties and they are already available from the optical industry, although made for quite different purposes.

The effect of this phase shift layer on the coherent light impinging on it can be described by a complex "modulating" function $\phi(w)$. Here, w is a normalized coordinate derived from x , so that $\phi(w)$ becomes independant of r and s , the distance between light source and phase plate, and phase plate and plane of observation, respectively:

$$w = \sqrt{\frac{\pi r}{\lambda s (r+s)}}$$

The actual intensity of the observed diffraction pattern, is given by the product of $|\phi^2(w)|$ with the intensity $I(w)$, which would be seen without phase plate in the beam. In any case, a central absolute minimum of intensity will be observed, as well as two adjacent maximums (fig. 1); if s is small additional insignificant maximums of decreasing intensity will be seen for larger values of x .

To give an idea of the width Γ of the central minimum we express Γ as a function of r and s , obtaining the result

$$(2) \quad \Gamma = \sqrt{\lambda s \cdot \frac{r+s}{r}}$$

Apparently, the width Γ is equal to zero at the phase plate where $s=0$, and increases proportional to the square root of s , provided that s is small compared with r . If s finally exceeds r , the width Γ increases linear with s , analogous to the beam width. Table 1 presents some characteristic values of Γ for different distances s under the assumption $r \gg s$.

s	1m	10m	100m	1km
[cm]	0.08	0.25	0.79	2.5

Although the production of an absolute minimum of intensity is completely sufficient for the alignment method to be described and although the sharpness of the minimum is theoretical without any interest, practical aspects may urge to reduce Γ in some cases. Therefore, we consider three possibilities:
 1) The combination of a laser and a phase shifting plate, shown in fig. 1, can always be used if $s \leq r$. Then, according to equation (2), Γ remains rather small and no modification of the layout is necessary.

2) It may occur that the relation $r \geq s$ cannot be satisfied, either if r is limited to a small distance or if the path s is very long, and the consequently resulting width Γ is too large. Then, a telescope focused to infinity should be placed into the beam between the laser and the phase plate. The effect is that the distance r becomes fictitiously enlarged. It seems, that the light source is displaced to a distance rV^2 , provided that the telescope with a magnification V is positioned directly in front of the phase plate. At the end of a 1 km-system the minimum width will decrease to about 3.5 cm.

3) To get the smallest minimum widths which are possible, a focusing device is needed. For this purpose, the phase plate can be combined with a Fresnel lens, resulting in values $\Gamma \approx \lambda s / D$, where D denotes the effective aperture of the lens. In analogy to the maximum method, that sharpness will only be observed at a certain distance s equal to the focal length of the lens. The axis of the system, however, is still defined by a line of zero-intensity.

The expediency of those three possibilities, however, can not be seen without having discussed the second part of the minimum method with respect to the principle and accuracy of the detection of the axis.

Detection of the Optical axis - asymmetry method

The optical axis of a system, which is defined by a line of no intensity, can be detected by means of a method, divided into four steps of increasing accuracy:

- Step 1: The central minimum is observed visually. If better accuracy is desired, step 1 can be used for preliminary alignment.
- Step 2: The central minimum of intensity is mechanically scanned by means of the same device which would be used for scanning a maximum of intensity.
- Step 3: The excellent coherence of the laser light permits to apply a very simple method which yields extremely high accuracy. In the plane PA where the axis is to be detected, either an ordinary slit or a rectangular aperture (detection in one or two dimensions, respectively) is placed into the minimum. Then, a certain light distribution is produced in a distance t behind PA, observable on a screen PB (fig. 2). If the aperture is exactly centered to the axis, this second diffraction pattern on PB is exactly symmetrical and looks nearly alike to the first diffraction pattern on PA. Essentially, the distribution on PB shows four symmetrical maxima, separated by two lines of zero intensity ("cross-wires"). A displacement between the aperture and the axis, however, results in characteristic asymmetries in the diffraction pattern on PB. This asymmetry, especially of the intensity of the maxima, is increasing with the displacement of the aperture. Therefore, both the amount and the direction of such a displacement can be measured by watching and comparing the intensity of the four maxima on PB. The asymmetry can be observed visually.
- Step 4: Analogous to step 3, the light distribution, however, is measured by means of photo-elements or other detectors sensitive to light (automatical test for symmetry).

Fig. 3 illustrates the asymmetry effects in one dimension, experimentally obtained with step 3 and 4. The diffraction pattern was scanned by a linear slit integrating over y and the resulting intensity distribution was plotted as function of x .

Fig. 3a shows a symmetrical distribution, the aperture (say slit) was aligned to the axis. A displacement of the slit in PA of 1%, 2%, 4% and 10% of its width results in the asymmetrical patterns shown in fig. 3b. to 3e.

The sensitivity of that asymmetry method is high enough to detect, for instance, an alignment shift of 0.01 mm, if a slit with a width of 1 mm is used (fig. 3b.). Moreover, this can be done visually. The diffraction pattern, however, is very simple and therefore the test for symmetry can be automated. A general calculation of that asymmetry leads to the formula

$$(3) \quad \frac{\Delta x}{d} = \frac{1}{g} \cdot \frac{\Delta I}{I_m}$$

where Δx represents the displacement between the slit and the axis of the system, d is the width of the slit, ΔI is the difference of the intensity of the two principal maxima and I_m denotes the maximum intensity in the case of symmetry. The factor g is somewhat dependent on the distance t (see fig.2.), an average value, easy to verify, is $g \approx 10$. Choosing shorter distances t , higher sensitivities are available. Of course, equation (3) is also valid for the coordinate y perpendicular to x .

The most important features and advantages of the asymmetry method can be summarized as follows:

- 1) Essentially, a laser and a phase shifting plate are the only substantial devices necessary to perform the alignment by means of the asymmetry method. An additional detection device is needed for an automated measurement, or if higher precision is demanded (two or four photocells would be sufficient). If the system is very long, ($s \geq 100$ m) it may be convenient to place a beam-bunching telescope in front of the phase plate.
- 2) Using step 1 and 2 the method is applicable in cases where no extreme accuracy is demanded. Nevertheless, alignment problems can be solved, where high precision is necessary (step 3 and 4, perhaps step 1 and 2 for initial alignment). The measurement can always be done both visually and automatically. In an extreme case, a precision of 10^{-8} rad is available ($\Delta x=0.01$ mm in a distance $s=1$ km, using an object slit with $d=1$ mm and detecting an asymmetry as large as $\Delta I/I_m \approx 10\%$). The clearly detectable asymmetrical effect $\Delta I/I_m$ is increasing linearly with increasing alignment shift Δx . Generally, that linearity is not disturbed before the relative displacement $\Delta x/d$ exceeds 10%.
- 3) The width d of the aperture is not subjected to any condition. The smaller d , the higher the accuracy of detecting the axis. It is important to point out the difference between relation (1) and

(3), the forms of which are looking quite similar. Equation (1) describes the alignment sensitivity for scanning a maximum and h denotes the width of the beam. This width, however, is a given quantity at all positions where objects are to be aligned, and therefore h can not be varied in (1). The width d , in contrast, can be changed even during the measurement. Therefore, the sensitivity of the asymmetry method can easily be increased or decreased, according to the demand. It should also be noted that the asymmetry method is neither affected by the width h of the laser beam nor by the width Γ of the minimum (that's why a telescope has no influence on (3)). The existence of the absolute minimum along the axis is sufficient to perform the alignment steps 1 to 4.

4) One of the most important features of the asymmetry method is the independence of the uncertainty Δx of both the distances r and s . Wherever the axis of the system has to be detected, either close to the phase plate ($s=0$) or at any distance s , the uncertainty Δx is always given by (3) and can be detected by means of the same device.

5) The asymmetries appear simultaneously in the two dimensions of the plane PB of observation. Nevertheless, the alignment can be done either in one or in two dimensions. In the last-named case it is possible to measure in the two dimensions both separately and simultaneously.

The advantages of that asymmetry method are obvious and its consequences on practical alignment of linear accelerators will be discussed in the following chapter.

Example for an accelerator alignment system⁸

Due to the flexibility of the asymmetry method, always the same principal experimental set-up can be used (fig. 1). Details are dependant on the special requirements for an accelerator in question. To give an example, we discuss a possible alignment system for a long linear accelerator, where any number of targets has to be placed to a straight line with an error of less than about 0.01 mm for all targets over an entire length of, say 1 km.

Fixed plane of observation. We assume that an eventual displacement of any target should be detected at a fixed plane of observation PB at the end of the accelerator. Then, the asymmetry method can be performed as indicated in fig. 4. All targets are represented by phase plates of the same kind, the center of which has to be aligned to the axis of the system. One target at a time is to be inserted in the laser beam and produces the described line of zero intensity. Therefore, information about the position of that target is transmitted to the plane of observation.

The detection unit consists of a quadratic aperture PA and, for example, of four photocells in PB. The center of this aperture represents one of the two points defining the axis of the system. For a given aperture, the location of all photo cells during the alignment remains constant and therefore, even for high precision alignment, the whole detection unit does not necessarily contain neither any movable parts nor any element of precision. If $I_1 \dots I_4$ denotes the signal (current) detected with the four photo cells, the displacement of the target in question is given by:

$$\begin{aligned} \Delta x &\sim A + B & A &= I_1 - I_3 \\ \Delta y &\sim A - B & B &= I_2 - I_4 \end{aligned}$$

According to (3), the alignment sensitivity is independent of the target position. If the laser output is high enough (~ 1 mW), displacements of any target of about 0.01 mm should be detectable visually on the screen PB.

The phase plates may have any size. A radius of the order of the first Fresnel-zone with respect to the distance to PA is sufficient. For a 1 km-system, the maximum radius would be less than 3 cm. The precision of the phase layer is examined later.

Variable plane of observation. Another possibility is to observe displacements close behind the target in question. In this case, only one fixed phase plate is needed at the beginning of the system and all targets are to be represented by quadratic apertures. Then, the alignment takes place in the usual manner as described above. A special possibility, however, is worth being mentioned.

In general, the laser beam should not be interrupted on its path to a target to be aligned. Therefore, if an aperture A2 at a distance s_2 is being aligned, any other aperture A1 at a shorter distance s_1 has to be removed. The asymmetry method, however, enables us to elude this restriction by means of a simple modification, shown in fig. 5. All diaphragms A1, A2... have to be replaced by mirrors M1, M2, ... of a corresponding size, positioned diagonally into the beam. The mirrors are reflecting a light distribution out of the beam, observable on screens PB1, PB2, ... at the side, which is completely identical to the diffraction pattern produced by a corresponding diaphragm. Thus, the center of a mirror is aligned on the axis, if the reflected intensity distribution is symmetrical. So far, the alignment itself does not change. The advantage, however, is evident. The optical axis behind an adjusted mirror M1 is still correctly defined by zero-intensity and, therefore, other mirrors M2, M3 ... can successively be aligned at increasing distances without removing the mirrors which are already adjusted. The limit of this method is given

by two facts: firstly, any remaining alignment shift of a mirror causes a certain distortion of the optical axis behind this mirror and secondly, each mirror takes some intensity out of the center of the beam and although light is diffracted to the following mirrors, the intensity impinging on them will decrease steadily. It should be mentioned that the unavoidable mounting supports of the mirrors are in no way disturbing, provided that they are symmetrical.

Limitations and Distorting Effects

According to equation (3), the accuracy Δx of the asymmetry method remains constant whatever distance of the object point is chosen. Therefore, the question arises, what effect is limiting the validity of (3) and, more general, what kind of effects are distorting the method in practical operation.

It is easy to explain the independence of the alignment sensitivity on both r and s . Relation (3) shows only the ratio $\Delta I/I_m$, but not the absolute values ΔI and I_m . An increase of s , however, results in decreasing intensities ΔI and I_m . Thus, the detection will cause serious problems if I_m becomes too small in a certain maximum distance S_L . Fortunately, the energy density in a laser beam is so high (even if the total output is only 1 mW) that other effects are distorting at much shorter distances than S_L . Hence, the intensity available for the detection must not be considered to be a problem and equation (3) can always be applied in practical cases. All other theoretical limits for the asymmetry method, such as the finite coherence length of the laser light, are insignificant and will not be discussed. Real problems may arise due to insufficiencies of the laser and the phase plate and possibly a telescope:

Laser: a simple He-Ne gas laser is sufficient for our purposes. The beam emitted in the normal transverse mode, should boast an excellent rotational symmetry. This is within reach by an appropriate choice of the construction and the mirrors of the laser. In the same way, the mechanical stability and the spatial constancy of the radiation (emission into a constant direction) can be controlled. Occasional variations of the intensity are not disturbing if differences like ΔI are measured.

Telescope: We have already mentioned that we can meet all requirements made on a telescope, which is eventually used. It is important to place the telescope symmetrically into the beam, that means the center of the laser beam and the optical axis of the telescope must coincide. For

high precision alignment, especially if large distances are involved, it is advantageous to use a spatial filter inserted into the telescope. By that, distorting rays can be masked and the beam becomes extremely pure and parallel. We point out that such filters can also be utilized in the detection unit in order to eliminate distortions of the absolute minimum to be detected.

Phase shifting plate: Assuming a pure laser beam, the phase plate is the only element which determines the maximum accuracy within reach. The phase plate consists of two different layers, which have to satisfy two conditions. At first, each homogeneous layer has to be of constant thickness, so that parallel wave fronts are remaining parallel while passing through and secondly, the two layers must be of different thicknesses, so that adjacent parts of the beam passing through are showing opposite phases. The better the second condition is fulfilled, the better is the maximum accuracy available with the asymmetry method. Any deviation from the ideal phase difference gives rise to asymmetrical contributions of intensity in the diffracted beam, thus distorting the optical axis of the system. A calculation of this effect shows that such errors can be made small⁸. At a distance of 1 km, for example, the shift of the minimum defining the axis can easily be kept below 0.1 mm (10^{-7} rad). Nevertheless, it should be possible to produce more precise phase plates. Moreover, compensation methods could be used. Although the phase shift layer must be a precision element, it is not at all introducing a technical limit for the accuracy of the alignment. We note, that the high precision of the phase plate is necessary only if rectilinearity is desired, in contrast to the detection of small movements of "fixed" object points.

High precision alignment in air is limited by turbulence and refraction. Therefore, if the accelerator is larger than say 30 m, the laser beam should be guided through an evacuated pipe. A pressure of about 10 micron will be sufficient so that high precision alignment is not disturbed.

Conclusion

Within the scope of this paper, only a rough perspective could be presented. Necessarily, a lot of details had to be omitted, which are closely related to the alignment of linear accelerators. The

asymmetry method is also of use for the adjustment of beam lines and other equipment in research laboratories. In addition, a great variety of very different alignment problems can be solved. Special designs of the asymmetry method should be developed such as devices for the detection of the asymmetrical intensities and a combined unit of telescope, spatial filter and phase plate. Finally, the future development of gas lasers promises to yield interesting results with respect to stability, handling, service life and beam quality. All that might contribute to an improvement of high precision alignment techniques with laser light.

Acknowledgement

It is a pleasure to thank Professor Ch. Schmelzer for his encouragement to this work, and many valuable discussions are gratefully acknowledged.

References

- 1) A. C. S. v. Heel, Progress in Optics, Vol. I, North-Holland Publishing Company, Amsterdam (1961).
- 2) W. B. Herrmannsfeldt, Proc. of the Lin. Acc. Conf., LA-3609, Los Alamos (1966).
- 3) H. Talbot, Phil. Mag. (3), Vol. 10, 364 (1837).
- 4) H. Bruns, Astr. Nachr. 104, No. 2473, 1 (1833).
- 5) Handb. d. Exp. Phys. 18, 306 (1928).
- 6) Handb. d. Phys. 20, 52 (1928), 21, 928 (1928), 24, 372 (1958), and Rev. Opt. 29, 307 (1950).
- 7) H. Wolter, Ann. d. Phys. 6, 341 (1950).
- 8) H. D. Betz, UNILAC-report No. 2-67, University of Heidelberg, Inst. f. Angew. Phys., (1967).

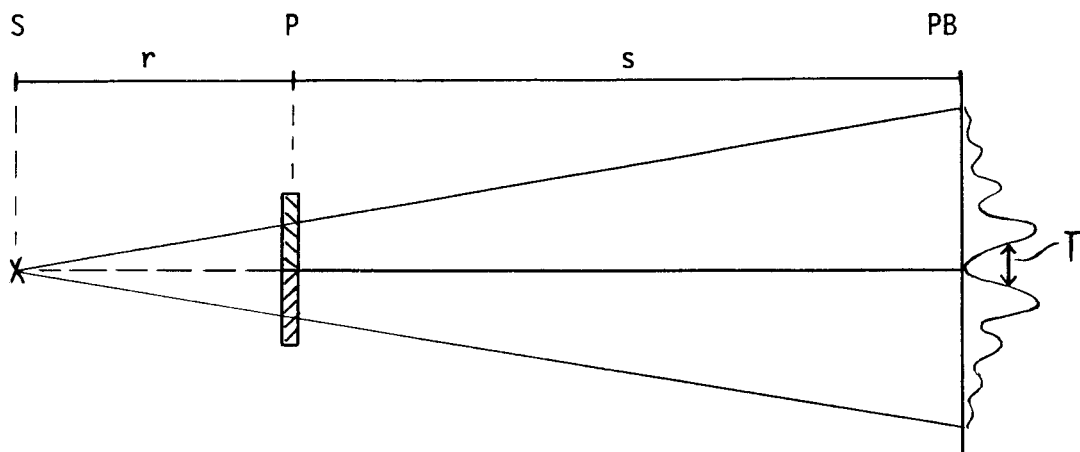

Fig. 1: Demonstration of the minimum principle. (S=laser source, P=phase plate, PB=plane of observation).

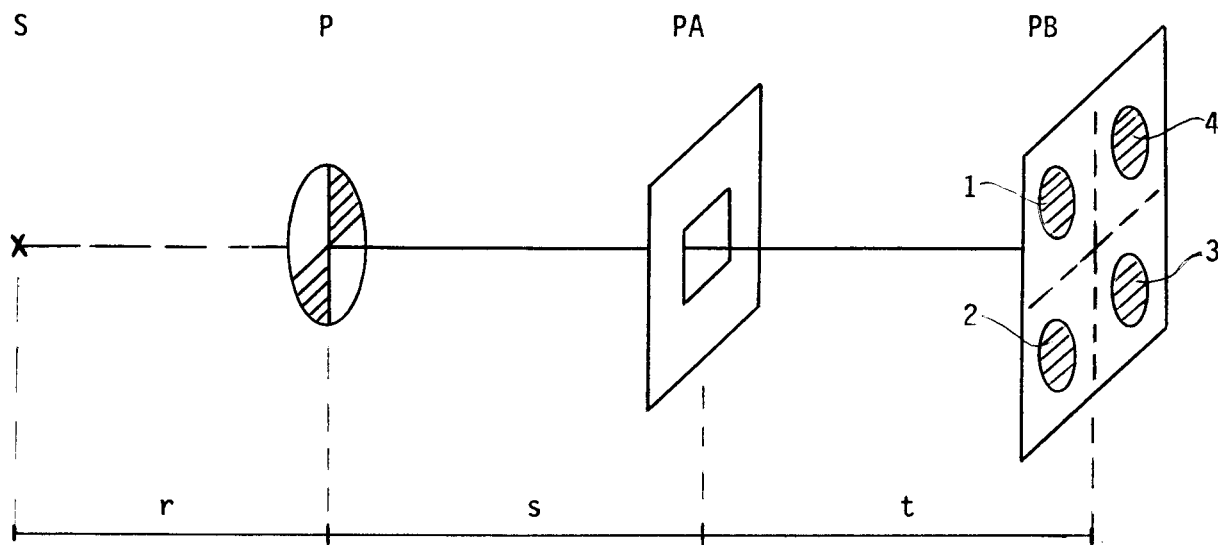

Fig. 2: Principle of the asymmetry method in two dimensions.

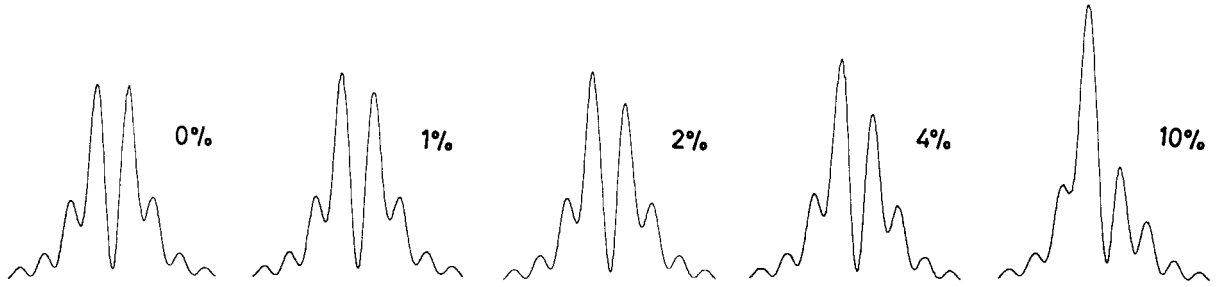

Fig. 3: Experimental intensity distribution, obtained at PB with the asymmetry method in one dimension. The slit to be aligned in the plane PA was displaced 0%, 1%, 2%, 4% and 10% of its width.

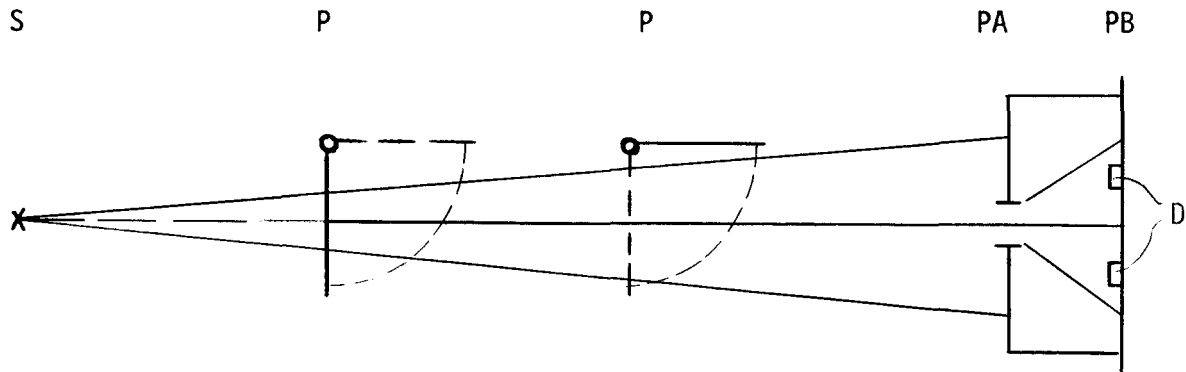

Fig. 4: Schematic diagram for an alignment system based on the asymmetry method with fixed detection unit (D=detectors).

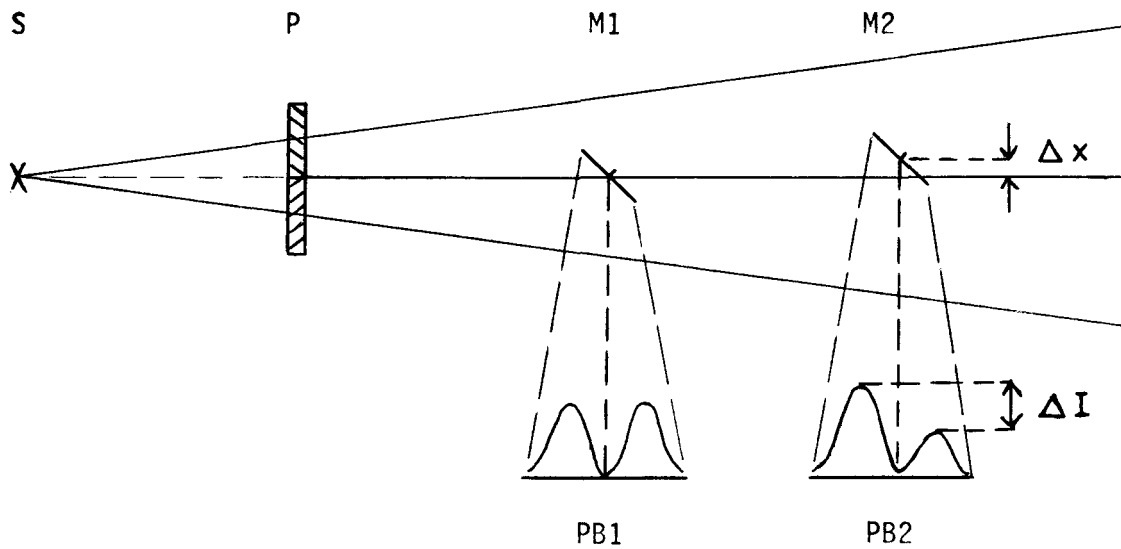

Fig. 5: Asymmetry method with variable detection plane and simultaneous alignment control (M1, M2 = mirrors).