

FIELD MEASUREMENTS OF VARIABLE  $\beta$  MULTI-STEM ACCELERATING STRUCTURE\*

S. Giordano and J. Hannwacker  
 Brookhaven National Laboratory  
 Upton, New York

Introduction

The purpose of this paper is to measure and evaluate the axial electric field distribution of a single and multi-stem drift tube support for a variable  $\beta$  cavity. Tests were performed on a cavity as shown in Fig. 1, the dimensions of which are shown in Table I. This model has a much greater change in  $\beta$  over its length as compared to a realistic cavity design.

Of primary interest are the changes of the average electric field caused by a frequency detuning perturbation, and the corresponding improvement one obtains with a four stem drift tube support as compared to a one stem case.

The variable  $\beta$  cavity is made up of different cells each having the same resonant frequency but a different length, resulting in a mismatch of fields between each cell. A consequence of this field mismatch is an intrinsic field variation. In some of the measurements, a tapered tuning bar was placed along the wall of the cavity to reduce the intrinsic field variation.

Method

Field measurements were made, using a standard technique employing a slaved oscillator and metal bead as shown in Fig. 1. The frequency perturbation measurements were recorded on tape, and a computer program was written to calculate and plot the values of  $E(z)$  [when  $E(z)$  is the peak electric field on the axis at the point  $z$ ]. Figure 2 shows a typical electric field plot across a single gap, as printed out on a recorder. From the above we can compute  $E_0$ , the value of the average electric field across each cell where

$$E_0 = \frac{1}{L_0} \int_0^{L_0} E(z) \sin\left(\frac{\pi z}{L_0}\right) dz,$$

and where  $L_0$  is the cell length.

Cavity Design

The electrical design of the cavity was based on both published<sup>1,2</sup> and unpublished data. The physical dimensions are as shown in Table I, and the stem diameters chosen resulted in a structure having the dispersion curve shown in Fig. 3. An undercompensated case was purposely chosen. In order to study the effects introduced by a variable  $\beta$  structure, this model was built with a grossly exaggerated change in  $\beta$  per unit length. This exaggerated change, which is eight times greater than the actual design of the 200 MeV Brookhaven Linac, clearly demonstrates any electrical field distortions that are introduced by

the changing  $\beta$ .

Results

Figure 4 is a plot of  $E_0$  along the axis of a cavity for both the one stem and four stem cases, without any compensation or perturbations. For the one stem case we see the severe field variations along the cavity, resulting from the mismatch of the fields between adjacent cells. For the four stem case, as seen in Fig. 4, there is a marked improvement in the field distribution. It should be pointed out that for the four stem case the Q was lower than the one stem case only by an amount directly proportional to the additional stem losses.

In order to better evaluate the four stem vs. one stem cases, a tapered tuning bar was placed along the wall of the cavity to reduce the intrinsic electric field variation caused by the change in  $\beta$ . Figure 5 shows the average electric field variation along the cavity with a tapered compensating tuning bar. Comparing Figs. 4 and 5 we can clearly see the effect of the tuning bar.

We now deliberately perturb the cavity by placing a shim under the half drift tube (making the half drift tube slightly longer) at the low energy end, resulting in a lowering of the resonant frequency. The resulting field tilt, for both the one stem and four stem cases are plotted in Fig. 6. From Fig. 6, we see that the resulting tank tilt caused by the perturbation is considerably less for the four stems as compared to the one stem supports. We can now define an improvement factor

$$I = \frac{E_0(\text{max})(1 \text{ stem}) - E_0(\text{min})(1 \text{ stem})}{E_0(\text{max})(4 \text{ stems}) - E_0(\text{min})(4 \text{ stems})}$$

From Fig. 6, substituting in the above equation we get  $I \approx 6$ . It should be pointed out that the improvement factor is directly related to  $L/\lambda_0$ , where  $L$  is the length of the cavity, and  $\lambda_0$  is the free space wavelength of the resonant frequency. The above measurements were made at 840 Mc and on a cavity 45" long. For a 60-foot cavity, operating at 200 Mc, the improvement factor would be approximately 25.

Conclusion

It has been clearly demonstrated that multi-stems can substantially reduce the electric field distortions introduced by both the change in  $\beta$  and those caused by detuning perturbations.

\*Work performed under the auspices of the U.S. Atomic Energy Commission.

The above model has a change in  $\beta$  per unit length eight times greater than the BNL design, and the spacing between the  $TM_{010}$  and  $TS_{001}$  mode (Fig. 3) is 43 Mc, while in the final design of the BNL linac this mode spacing will be considerably less (between 0 to 10 Mc).

Even with the above conditions, the improvement factor brought about with multi-stem is quite good. In the actual linac where the  $\beta$  variation and mode spacing will both be less, the improvement factor will be many times greater.

Table I

<u>Cell No.</u>	<u>Cell Energy</u>	<u>Cell Length (inches)</u>	<u>Stem Diam.</u>
1	50 MeV	4.160	.190
2	60	4.558	.238
3	70	4.945	.262
4	80	5.340	.286
5	90	5.718	.333
6	100	6.060	.357
7	110	6.340	.405
8	120	6.587	.429

Acknowledgement

We wish to acknowledge the valuable contributions of Messrs. R. Stoehr, and R. Coligny for obtaining the experimenter's data.

References

1. MURA - Extensive MESSYMESH Data
2. S. Giordano and J. Hannwacker, IEEE Trans. Nucl. Sci., NS-14, No. 3, 290 (1967).

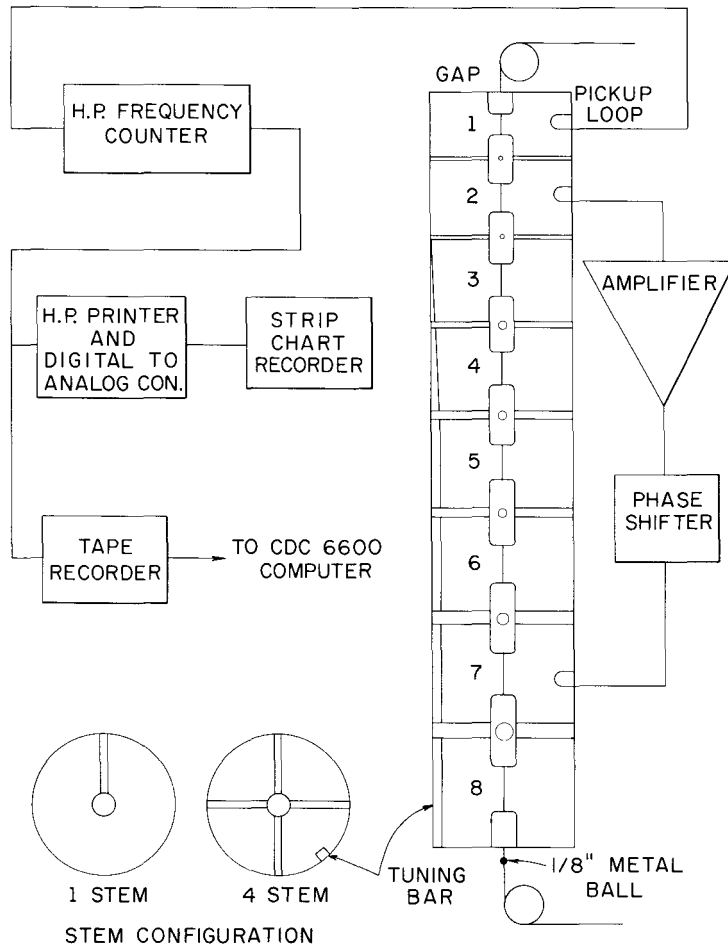

Figure 1 - Bead Pulling Instrumentation

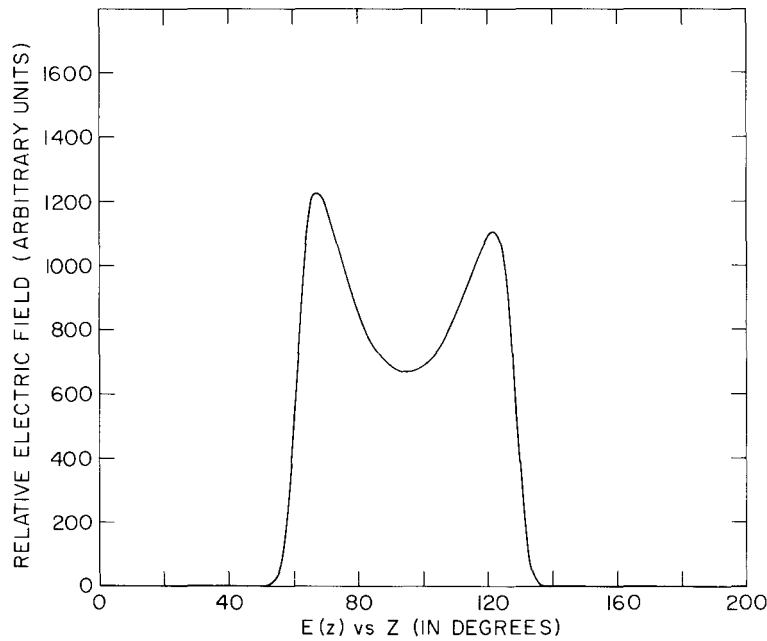

Figure 2 - Typical Electric Field Profile of One Gap as Produced by the CDC 6600 Cal Comp Plotter

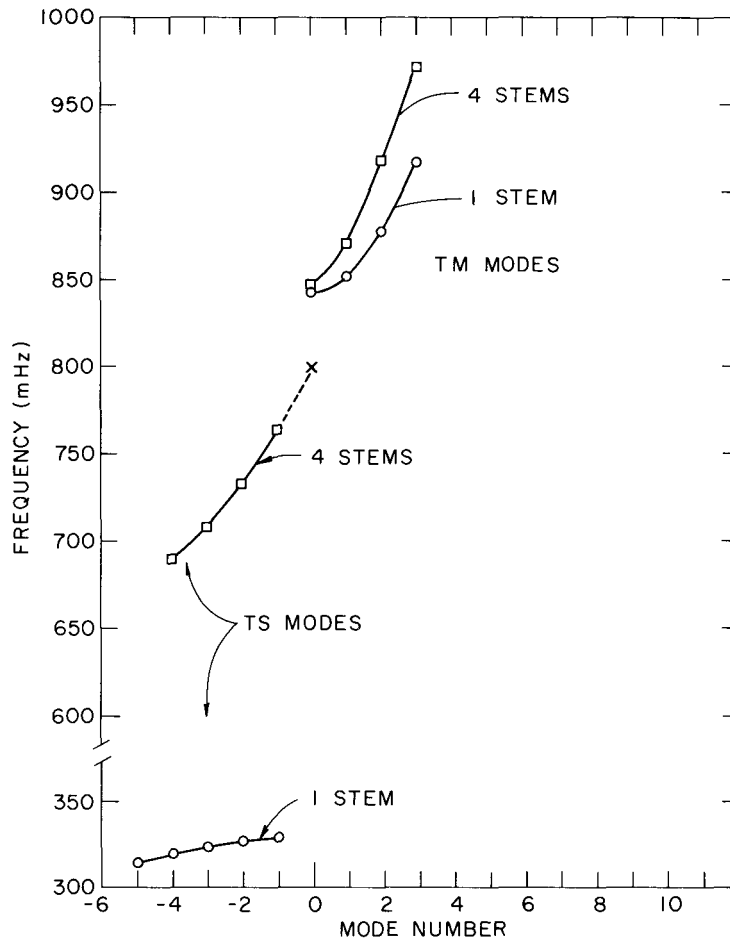

Figure 3 - Dispersion Curve for Variable  $\beta$  Cavity for One and 4-Stem Configurations

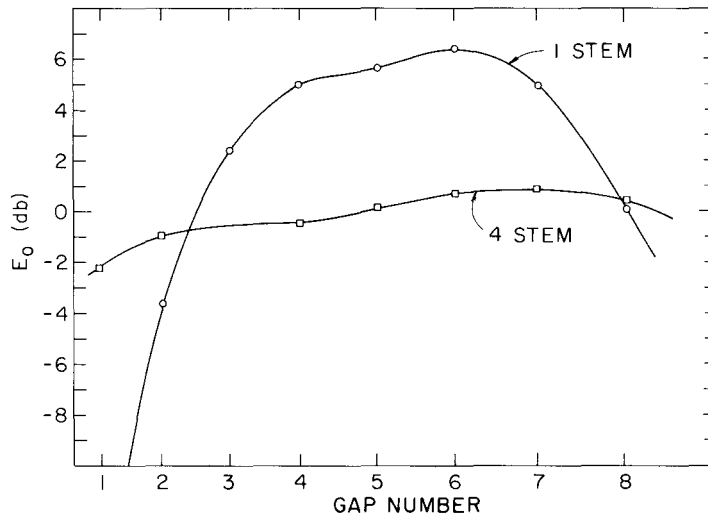

Figure 4 -  $E_0$  for One Stem vs 4-Stem Without Compensation and With No Perturbations

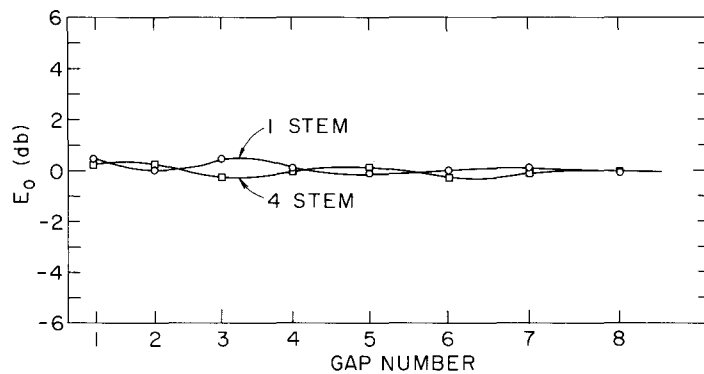

Figure 5 -  $E_0$  for One Stem vs 4-Stem with Compensating Bar and With No Perturbations

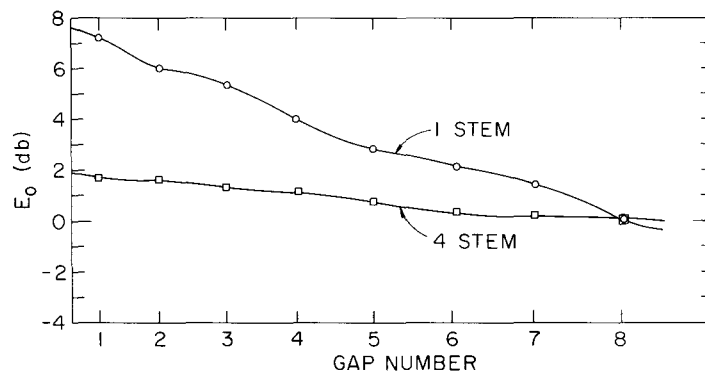

Figure 6 - Actual Electric Field Measurement of the Bar Compensated Cavity With a Perturbation Added