

RECENT DEVELOPMENTS AT SLAC *

R. H. Helm, G. A. Loew, R. H. Miller, and R. B. Neal
 Stanford Linear Accelerator Center
 Stanford University, Stanford, California

The objective of this paper is to report some of the recent results obtained at SLAC in conjunction with the operation of the two-mile accelerator and to describe various key improvement programs which are now under-way or projected in the near future.

1. SLAC Operating Statistics

The SLAC accelerator has been engaged in a program of particle physics research since the last quarter of calendar year 1966. Since then, the number of operating shifts per week devoted to particle physics has steadily increased while the shifts used for machine physics have decreased. This trend is illustrated in Fig. 1. Because of budgetary limitations, the total number of scheduled shifts has declined in the two most recent quarters shown but is expected to increase somewhat during the last quarter of the fiscal year 1968.

A more detailed account of operations during the first three quarters of FY 1968 is given in Table 1. In addition to showing the number of hours devoted to machine physics and particle physics, a breakdown of the non-productive hours is given. The general trend of these non-productive hours is downward but continuing efforts are being made to understand and further reduce lost time in the various categories. The total experimental hours accumulated for particle physics in the three end stations exceed the actual beam hours for particle physics, reflecting the fact that several experiments are often carried out simultaneously using time-interlaced beams. In Table 2, the times devoted to the various tasks are expressed as percentages of the total manned hours during each quarter.

2. Experience With High Power Klystrons

There is a total of 245 high power klystrons attached to the two-mile accelerator. These tubes are rated at 21 MW peak and 21 kW average power. They operate typically at a pulse length of $2.5 \mu\text{sec}$ (flat top) and 360 pulses per second. Their gain is $\sim 50 \text{ dB}$ and their efficiency $\sim 35\%$. At the present time, the 245 klystron sockets along the accelerator are filled with 101 RCA tubes, 86 Litton tubes, 55 SLAC tubes and 3 tubes from earlier contracts with Eimac and Sperry.

Klystron usage and failure data are shown in Table 3. Operating hours, number of failures, and mean age at failure are given on a quarterly and also on a cumulative basis. Altogether, the results cover a time span of about 2 years. During the past four quarters, an average of about 300,000 klystron hours per quarter has been experienced. From another point of view, this means that each of the 245 klystron stations attached to the accelerator has operated about 57% of the available time during the past year. Operations were restrained to this level by the available operating budget, rather than by klystron (or overall machine) capability or physics demand.

During the past year the number of klystrons failing per quarter has averaged 24, or one failure for every 12,600 hours of klystron operation. The history of mean time between failures (MTBF) is shown more completely in Fig. 2. One notes that, except for occasional setbacks, the trend of the MTBF has been generally upward. A value somewhat above 15,000 has been attained in the most recent quarter shown. Also shown in Fig. 2 are the mean age of all operating tubes on the accelerator (now about 6000 hours) and the mean age at failure during each quarter (about 4500 hours during the most recent quarter). Both of these quantities have increased steadily and should (for a normal failure distribution) eventually approach the MTBF. However, it should be emphasized that the failure mechanisms (window failures, gassing, development of oscillations, instabilities, etc.) which now curtail tube life will not necessarily continue to be the dominant causes of failure as the mean age of the tube population increases. True "wearout" (cathode depletion, etc.) has not yet been encountered to any degree, but it could begin to take its toll at any time.

Another look at the MTBF data, omitting the results experienced with the tubes of the least successful manufacturer, is shown in Fig. 3. Here, MTBF is given on both a quarterly and a cumulative basis. Neglecting the one anomalous quarter when the MTBF rose to the extraordinary level of $\sim 29,000$ hours, it may be observed that both the quarterly and cumulative values of MTBF have hovered about the 14,000 hour level during most of the past year. Because of the uncertainty concerning future failure mechanisms in the aging tube population, as discussed above, it is still too early to predict mean tube life with very great accuracy. It would be premature at this time to predict a mean life as high as 14,000 hours. On the other hand, a mean life of 8,000 - 10,000 hours can be projected with reasonable conservatism. Further basis for such a prediction is given by the plot of age distribution of klystrons now in service as shown in Fig. 4. The observation that the peak of this distribution lies in the 7,000 - 9,000 hour range and the fact that wearout phenomena have not yet been exhibited to a noticeable degree in the oldest tubes now operating, lend credibility to the mean life projection made above. As noted in the figure, the mean age and the median age of all tubes connected to the accelerator as of May 1, 1968 were 6,000 hours and 6,950 hours, respectively.

Klystron failure probability per unit time (percent failure per 1000 hours) is shown in Fig. 5. Within statistical accuracy, the probability of failure is constant over the range of 2,000 - 8,000 hours. From the same data, the survival ratio shown in Fig. 6 can be plotted.

Attempts have been made to determine mean life of klystrons under different operating conditions. The principal parameters which have been varied are beam voltage and pulse repetition rate. Beam voltages from ~ 200 to 250 kV and repetition rates between 60 and 360 pulses per second have been set up in different sectors of the accelerator (there is a total of 30 sectors, most of which

* Work supported by the U.S. Atomic Energy Commission.

contain 8 klystrons each). No significant effect of pulse repetition rate upon mean life has been found. The total number of hours of operations may not have been great enough to reveal a small effect. Similarly, no significant effect on life has yet been observed as a function of beam voltage. However, it has been found that the number of troubles of all types reported during a given time interval at klystron-modulator stations in sectors operating at 245 kV are about twice as numerous as in sectors operating at 235 kV klystron beam voltage. It is not yet clear how the trouble report rate and klystron life are correlated, if at all. The gathering of data of this type is continuing. At the present time, six sectors of the accelerator are being operated on a standard basis at 245 kV while the remaining 24 sectors are being operated at 235 kV.

SLAC has extended warranty contracts with its two principal klystron subcontractors, RCA and Litton. Under these contracts, SLAC purchases the initial tubes outright; during operation SLAC pays the manufacturer an hourly rate which depends upon the length of time the tube has been in service. When the tube fails, the manufacturer replaces it without further cost to SLAC. The hourly rates paid to the two companies and the average hourly cost as a function of tube life are shown in Fig. 7. The meritorious feature of these extended warranty arrangements is that both the manufacturers and SLAC have strong financial incentives to achieve long tube lives.

3. Development of High Efficiency Klystrons

The power output vs. beam voltage of all the tubes originally connected to the accelerator (November 1966) is shown in Fig. 8. The mean power output is approximately 12 MW at 200 kV and 21.7 MW at 250 kV. The standard deviation and the maximum and minimum power outputs vs. beam voltage are also shown.

There are obvious reasons why it is desirable to increase the efficiency of the klystrons from the original value around 35% to a higher value. Such improved tubes of a given input rating can continue to be operated in the same sockets and powered by the same modulators while their higher output would result in greater energy imparted to the accelerated electrons. Moreover, the transition from lower to higher efficiency tubes can be accomplished on a gradual basis as the older tubes fail and are replaced. For these reasons, a program to improve klystron efficiency has been underway at SLAC since 1963 and has produced results which are illustrated in Fig. 9. The improvements shown have resulted from the gradual optimization of the basic tube design parameters (drift distances, drift tube diameters, cavity gap lengths and magnetic field configuration). This process is still continuing. Best results to date are ~30 MW at 250 kV and ~34 MW at 270 kV. Using a special test modulator, tubes have produced ~43 MW at 300 kV.

The present goal is to build a significant number of laboratory tubes which can duplicate the best performance (~34 MW) achieved at 270 kV. This is the maximum voltage at which the existing modulators can be operated. If this objective is met, it is hoped that production tubes of this design will be able to produce 30 MW consistently at 260 to 265 kV. Gradual replacement of failed tubes with higher efficiency tubes will start in FY 1969. Hopefully, the excellent life experience of the existing tube types will be equalled by the new tubes. The

slow rate of replacement should result in reduced risks because of the fact that time for corrective measures will be available; alternately, continued use of the older tube types for a period of time is a possible fall-back position.

When all the existing ~20 MW tubes connected to the accelerator are replaced with ~30 MW tubes, the principal result will be an increase in maximum beam energy by a factor of $(30/20)^{1/2} \approx 1.22$, i. e., to the level of approximately 24.5 GeV. The maximum beam current should be increased by the same factor.

4. Second Injector

The original plans for the SLAC accelerator included three injectors. The second and third (or "off-axis") injectors were to be in rooms shielded from the main accelerator tunnel and located respectively at the one-third and two-third points along the two-mile accelerator. They were intended to serve two primary functions:

1. Permit easier and higher current operation at energies well below the design energy of the accelerator.
2. Improve machine reliability by having three injectors, any one of which could be repaired while the electrons from either or both of the others were being accelerated.

The 35 MeV beams from the off-axis injectors were to be deflected into the accelerator by an isochronous, achromatic magnetic inflection system.¹ However, these off-axis injectors were deleted from initial construction to reduce cost.

The experience of 18 months accelerator operation indicates that it would be desirable to have a second injector for low energy beams for the following reasons:

1. Low energy beams exhibit poor energy spectra because the beam loading energy transient occupies approximately half of the beam pulse and its magnitude is proportional to the length of accelerating structure through which the beam must pass. For the entire two-mile machine, the beam loading transient is 35 MeV/mA whether the accelerator sections are driven or idle.
2. The beam breakup current threshold² decreases with increasing length of accelerating structure through which the beam must pass.

However, the cost of installing the second injector in a room shielded from the main accelerator tunnel no longer seems justified for several reasons. Routine maintenance of the components of the injector which are mounted in the tunnel can be easily accomplished during scheduled down periods and extremely little operating time has been lost because of failure of tunnel-mounted injector components. Furthermore, residual radioactivity in the main accelerator tunnel presents no problem to maintenance except near the positron source, and radiation levels in the accelerator tunnel during operation are very low and should not reduce the useful life of any of the tunnel-mounted components of a second injector.

Consequently the installation of a second injector is being considered with all beam components in-line with the accelerator except for the electron gun and one gun lens. This injector will be used when the required energy

is about one-third or less of full energy. A schematic layout of the proposed second injector is shown in Fig. 10. As shown, use will be made of the klystron, klystron modulator, klystron control, interlock and monitoring circuitry, accelerator support structure, alignment hardware, and part of the high power waveguide which are already installed at the location of the proposed second injector. The klystron output power will be split with 50% going to the injector buncher and accelerator section, and 25% going to each of the next two 10-foot accelerator sections through the existing couplers and waveguides. This arrangement will reduce the energy contributed to a beam by this klystron by about 15%. Installation of the new injector on the axis of the accelerator and the resultant use of already installed equipment will reduce the cost by a factor of about 4 below the cost of the originally planned off-axis injector.

The 80 keV beam from the gun will be bent into the main accelerator axis before bunching because the velocity modulation produced in the bunching process would significantly complicate the inflector design. On the other hand, the weak rf fields used in bunching will have a completely negligible effect on the relativistic beam from the main injector. The inflector will be a small iron core dc magnet with a field of a few hundred gauss. An identical magnet powered in series, with the field reversed, will cancel the transverse impulse given by the inflector to a relativistic beam from the main injector. The transverse offset given such a beam is completely negligible.

5. Positron Source Developments

The positron beam at SLAC³ is generated by a technique similar to that used at other electron linacs. An electron beam is accelerated in the first third of the machine; at an energy of about 6 GeV, it strikes a radiator located on the axis of the machine. The radiator is several radiation lengths thick. A small fraction of the positrons emerging from the radiator is focused and accelerated in the remaining two-thirds of the machine in which the rf phase is shifted by about 180°. The positron beam is characterized by a maximum energy which is two-thirds of the maximum electron beam energy, by an intensity which is a few percent of the intensity of the electron beam striking the radiator, and by a transverse phase space which is much larger than that of the usual electron beam. In fact, the phase space is about the maximum that the machine will transmit, $0.15\pi(\text{MeV}/c)(\text{cm})$.

The SLAC system differs from other positron systems largely because of the high power available in the incident electron beam (up to several hundred kilowatts) and the high energies involved. The high power gives rise to severe thermal problems, both pulsed and steady-state, and also to significant radiation problems. Levels on the order of 10^7 rad/hr exist near the radiator when it is in use at full beam power, and residual radiation levels in excess of 10 rad/hr have frequently been encountered. Since the incident electron beam has an energy of 5 to 6 GeV, the radiator should have a thickness about equal to the shower maximum at this level; in copper, this thickness is several inches. The system that has been built has a wide positron energy acceptance. Such a system seemed promising because the initial energy spread of the positrons at the source (typical useful range between 5 and 15 MeV) becomes unimportant

at the end of the machine in relative value when the positrons emerge at energies of several GeV.

The decision to locate the radiator one-third of the way from the injector was rather arbitrary. It represented a compromise between the conflicting desires of high positron intensity, which requires high electron power incident on the radiator, and high final positron energy which requires that the radiator be placed toward the front end of the accelerator. The experimental uses for the positron beam are the scattering of positrons on protons, the generation of a monochromatic photon beam by positron-electron annihilation, and injection into the proposed positron-electron storage ring.

The positron source has operated approximately 1300 hours. The running time has been about equally divided between three targets: (1) a "slug", (2) a "wheel", and (3) a "wand".

The slug is a fixed cylindrical block of OFHC copper which has been slotted radially for water-cooling channels to a depth that keeps solid copper throughout the beam path. The beam path through the copper is 2-1/8-inches long. The slug is designed for, and has been run at, incident powers up to 70 kW.

The 2-inch-wheel target (see Fig. 11) is a solid copper ring, 2.1 inches along the beam axis. The wheel is moved in a circular path without rotating so that a fixed incident beam traces a two-inch circle centered on the ring. Outside the beam path, the wheel is slotted to provide water-cooling passages. The wheel has been run with incident beam power up to 140 kW at an orbital speed of 135 rpm. After accumulating approximately 20 MW-hours of incident beam, the wheel was removed from service (before failing) because of the beam damage shown in Fig. 12. The damage consists primarily of radial cracks emanating from the locus of the beam exit. The cracks appear to stop approximately 3/16-inch short of the inner diameter of the water-cooling passages. The shower diameter is believed to be about 5 mm at the beam exits,⁴ and at 135 rpm the target moves by the beam spot with a speed of 35.5 cm/sec, or almost exactly 1 mm per beam pulse. With 140 kW average incident beam power, the transient temperature rise has been calculated to be 190°C. The average temperature during full power operation has been measured with thermocouples on the inner cylindrical surface near the beam exit as $\sim 200^\circ\text{C}$. An identical replacement 2-inch-wheel target is now being installed. It will be operated at the same power levels, but with the orbital velocity increased to 190 rpm. This should reduce the transient temperature rise about 30%.

At present the incident beam power at full repetition rate is limited by beam breakup to 210 kW, or 50% more than the 2-inch wheel can handle. The limiting factor in the orbit diameter that can be used is the availability of bellows for sealing the drive arm. The bellows must survive millions of cycles with a stroke equal to the orbit diameter. A bellows has been successfully tested with a 3-1/2-inch stroke. In the summer of 1968, a 3-inch wheel will be installed using this bellows design. When the beam breakup program discussed in Section 6 of this paper is completed, it should be possible to deliver a 300 kW beam to the positron target. To handle this beam, development of a 5-inch wheel and suitable bellows is planned.

The wand target is used when only a few pulses per second of positrons are needed for a bubble chamber experiment; electrons are accelerated for the remaining machine pulses. The wand target is a thin arm which swings through the beam one to three times a second, blocking the beam aperture for about 25 milliseconds on each passage. The principal difficulty with this mode of operation is finding a suitable compromise for steering and focusing the electron and positron beams, since the steering dipoles and quadrupoles along the accelerator are all dc except for two sets of pulsed dipoles at the positron source. While a suitable compromise is possible, and several reasonably satisfactory wand runs have been made with interlaced electron and positron beams, the setup and maintenance of such beams is a delicate operation. Installation of pulsed quadrupoles and additional pulsed dipoles is planned at selected locations along the machine to facilitate these runs and multiple energy electron beam runs.

The positron yield was disappointing during early operation of the source, but has improved significantly. The biggest improvement occurred when the high field (~ 14 kG) solenoid at the target was realigned, and compensation was added to cancel the stray transverse fields from the busses to the uniform field solenoid. Since then, it has been possible to get 4% electron-to-positron conversion (positron current measured at end of accelerator) with a 6 GeV incident electron beam. Two-thirds of the positron current falls within a 1% energy spread.

6. Beam Breakup Remedial Program

As has been described in several recent papers (see for example Ref. 5), the beam breakup problem at SLAC is now reasonably well understood. An analytic solution has been successfully proposed⁶ and a computer method² is capable of predicting most of the beam breakup phenomena observed on the two-mile accelerator. The beam breakup threshold which, at turn-on of the machine, occurred at approximately 20 mA for a pulse length of 1.6 μ sec and an energy of 16 GeV, has now been raised to slightly over 40 mA. This improvement is entirely due to the focusing system installed during the course of 1967. This system, which is described in detail elsewhere,^{2,7} consists of quadrupole singlets every 40 feet in the first six sectors of the accelerator (≈ 600 meters) and strong doublets at the end of each sector from there on. At the maximum operable level, it results in beta-tron wavelengths of 125 and 400 meters, respectively.

While the beam currents obtainable with the present system are adequate to satisfy the majority of SLAC users, there are still strong demands for current increases and for further research and improvement. When several beams are accelerated simultaneously, the focusing system lacks operational flexibility because it must always be adjusted to the lowest energy beam to avoid stop-bands. In the limit of short pulses (≤ 100 nsec) or in the case of bunching at low subharmonics, a large number of the resonant modes of the accelerator section^{2,5} act cooperatively: as has been shown, the beam breakup thresholds drop abruptly and it becomes difficult to obtain computer agreement with experiment. Finally, the starting conditions of beam breakup are still not well understood.⁵ The failure of an array of 30 dB 4140 and 4428 MHz filters installed on the first ten klystrons to produce any threshold change, seems to have

eliminated klystron noise power as the prime source. However, it is still not clear which of the remaining contenders, namely shock excitation ($\sim I^2$) or injector shot noise ($\sim I$) is dominant.

Present efforts are directed at trying to produce a substantial threshold increase (of the order of 30 percent) by shifting the beam breakup resonant frequencies in one part of the accelerator with respect to another. Improvement factors to be expected by detuning several sectors are plotted in Fig. 13 vs. frequency. Extensive microwave tests on existing spare accelerator sections have confirmed that the first resonance (4139.6 MHz) and all subsequent ones (4147.50, 4154.00, 4159.72 MHz, etc. . . .) can fairly easily be shifted upwards by 2 to 4 MHz. Such shifts can be obtained by permanently tuning or "dimpling" a few of the cavities in which the resonances take place in each 10 ft. accelerator section. The optimum detuning of the first three or four of these resonances is achieved by applying the external deformations at four points per cavity at 45° with respect to the direction of the input coupler, in cavities 3, 4 and 5. With this orientation, both vertical and horizontal frequencies, which in some sections differ by as much as 1 MHz because of initial mechanical asymmetries, are shifted equally. A 3 MHz increase corresponds to an average of 9 degrees phase shift per cavity at the accelerating frequency (2856 MHz). The resulting decrease in energy gain would thus be negligible since a total of about 30 degrees phase shift (accumulated in the first five cavities out of 86) can be easily compensated by a small phase change at the input of the corresponding klystron. The resulting increase in input VSWR also appears to be controllable to within adequate limits (< 1.1).

Present plans are to test the final feasibility and safety of the "dimpling" technique on one of the first accelerator sections in the machine. A simple tuning tool and phase bridge are being prepared. If no surprises are found under high power operation, it is planned to apply this technique in the summer of 1968 to several sectors of the machine. Figure 14 gives the improvement factors that can be expected from possible "dimpling" schedules. Which of these will be adopted has not been decided at this point.

7. Breakdown of Main Drive Line

A major equipment failure which took place in April 1968 seems worthwhile reporting here because it was totally unexpected and it kept the entire accelerator inoperative for several days. The failure appeared in the form of an electrical short and a small local fire in the main drive line. This main drive line, which has been described in detail elsewhere,⁸ is a commercially built 3-1/8-inch coaxial line which extends along the entire length of the accelerator and supplies each of the 30 sectors with approximately 4 watts of cw power at 476 MHz. The cause of the initial reflection which eventually precipitated the short is still unknown but the result manifested itself in two severely burned center conductors, interconnecting bullet and expansion joint at the end of sector 6 (see Fig. 15). With an input power of 17 kW cw at the beginning of the line and an attenuation of 0.25 dB/100 ft., the normal power level at this point is only about 6 kW. Subsequent examination of the line revealed several other problems which had not been apparent before, namely: intermittent contacts between

twenty-foot drive line sections due to bowed flanges and loose connecting bullets; bowed teflon insulators; signs of arcing in the first 600 feet of line; arcing and poor sliding contacts in some of the expansion joints; and a general degradation of the VSWR of the line from original values of ~ 1.05 to ~ 1.2 or greater. The poor flange and bullet contacts and bowed insulators in the early part of the accelerator were most probably due to the stresses and strains caused by the differential expansion of the outer conductor which is temperature controlled to 113°F with respect to the inner conductor which, at maximum power, can heat up to approximately 160°F . Arcing may have taken place because of accidental, intermittent reflections and an unfortunate failure to use dry air in the pipe during an unknown period of time. In view of these problems, the first half of the line (one mile) was entirely disassembled, cleaned, the flanges faced off, the bullets replated with silver and rhodium flashed, the teflon insulators replaced and all expansion joints cleaned and reworked. Within less than ten days, the entire line was reassembled, the VSWR was considerably improved and the system was back in operation except for the water cooling and insulation which are gradually being reinstalled. Plans for the near future are to procure four new couplers for the downstream end of the line which will allow a general relocation of all other couplers upstream. This shift will allow reduction of the input power by 3 dB and the entire system to be run at a more conservative level. In addition, other mechanical improvements and a carefully planned preventive maintenance program are being prepared.

8. Instrumentation and Control Improvements

The quest for greater operating efficiency and improved beam quality requires continual upgrading of the Instrumentation and Control systems. Some of the improvements which have recently been incorporated or are presently being installed are listed below:

- a. Installation of a video switching system which enables the operators in the Central Control Room to select and view such video pulses as klystron rf envelopes, phasing pulses from the automatic phasing system, and beam pulses from a given sector toroid current monitor.
- b. Switchable 180° phase shifters at each sector input which enable the operator to use any one of the sectors, not only for positron acceleration, but also for electron deceleration when low energy beams have to be made compatible with simultaneous high energy beams.
- c. Remote balancing of the diodes which are used to obtain beam position information; these diodes are required to operate over a wide range of beam currents and require frequent rebalancing.
- d. Installation of a high fidelity communications system between the Central Control Room, the Data Assembly Building and the various experimental stations in the research yard. In addition to higher fidelity, this system is being built with a flexible switching matrix which enables the operators to establish conference calls with several groups of experimenters without degrading the overall quality of the system.

In addition to these and other changes, plans are being made to increase operational flexibility and beam

quality through the incorporation of three features operable on a pulse-to-pulse basis: pulsed steering, pulsed focusing and pulsed beam loading compensation. These three features, after proper design and prototype development, may be installed on a few sectors of the accelerator and used for the separate control of simultaneous beams. Eventually, they should result in better individual beam spots, pulse shapes and energy spectra.

In parallel with these improvements on individual systems, several programs are being implemented in both the Central Control Room and the Data Assembly Building to improve overall operation. For the Central Control Room, procurement of a PDP-9 computer and associated disk for control purposes is in process. An extensive list of control and data logging jobs for this computer has already been outlined and it is hoped that by the end of 1968, the computer will have been delivered and the first task, namely an automatic klystron replacement program, will be underway. In the Data Assembly Building, plans are presently being made to redesign and relocate the entire control console. In the new design, dual beam controls will be installed so that during periods of peak demand on the operators, separate operators will be able to control separate beams from different, symmetrical positions in the console.

In addition to the console redesign, the SDS-925 computer control system in the Data Assembly Building which has been inoperative for several months is being reactivated.

For the more distant future, studies are being carried out to examine the feasibility of eventually unifying the controls of the two control rooms. Various incremental plans are being studied. These range from minor improvements in the present system, computer communication between the two control rooms, to a complete transfer of all the equipment racks and control consoles presently in the Central Control Room to the Data Assembly Building.

9. RF Particle Separator

During 1967, it was decided that an rf separated K beam would be built in the extension of the central leg of the SLAC beam switchyard. This installation was built in less than six months and has been operating successfully in conjunction with the LRL-SLAC 82-inch bubble chamber since early February 1968.⁹ The radio-frequency system consists of a 2856 MHz drive signal derived through multiplication by 6 and amplification of a 476 MHz signal. The latter is obtained from an extension of the SLAC main drive line. The rf separator is powered by a standard SLAC 24 MW klystron-modulator complex, pulsed at 60 pps, although the repetition rate of the bubble chamber beam is only 1-2 pps. The rf separator structure design (LOLA IV) closely resembles earlier SLAC proposed designs.^{10,11} The relative group velocity (v_g/c) of -0.0189 was chosen as a compromise between best acceptance, highest shunt impedance and lowest susceptibility to electrical breakdown at high power. The original plan was to build a 10-foot structure but warnings from other laboratories^{12,13} of possible breakdown at 24 MW prompted a last-minute increase to a 12-foot section which could yield the same deflection at a slightly reduced input power. Table 4 gives a summary of the separator's characteristics. Except for some difficulties encountered in matching and tuning an early

test section, the fabrication of the structure was achieved without problems. The early difficulty was eliminated when it was discovered that the first few cavities shrank slightly during the brazing operation.

Under normal operating conditions, the rf separator gives a peak-to-peak deflection of 4.6 milliradians to an incident 12 GeV π^+K^+p beam. When kaons are desired, the pions and protons are rejected, and vice-versa. The transverse momentum of 27.6 MeV/c is obtained at an operating klystron power level of ~ 22 MW. So far, no signs of electrical breakdown have been apparent, even at powers as high as 25 MW.

10. Use of the SLAC Laser Alignment System For Interferometric Measurements of Earth Strains

Ever since the inception of the SLAC laser alignment system,¹⁴ it has been thought that under certain modifications, the system could be transformed into a long interferometer to measure earth strains. Recently, a proposal¹⁵ suggesting the utilization of the system for this purpose has been submitted to various agencies. The principle of the proposal is illustrated in Fig. 16. While the present lasers used for alignment point from East to West, the interferometer laser would be at the West end. The interferometer proper would consist of two arms: a short stable reference arm at the West end, and a long arm which would use part of or the entire length of the alignment tube. A cube-corner light-reflector would be placed on an existing concrete monument at the end of this arm. Any change in length of the 1.6 or 3.0 km arm would then manifest itself in a fringe displacement at the detector. A six-kilometer light path is equivalent to approximately 10^{10} wavelengths of the light emitted by a helium-neon gas laser (6328 angstroms). With a fringe counter sensitive to a shift of 1/4 of a fringe, the limiting sensitivity of the system would be approximately one part in 4×10^{10} , yielding a strain measurement of $\Delta\ell/\ell = 2.5 \times 10^{-11}$.

While there are admittedly several technological problems to be solved, namely laser stability ($1:10^{11}$ for short term), laser pointing control (to within 10^{-5} radians), improved vacuum (from the present 2×10^{-2} torr to 2×10^{-4} torr), specialized reflector and fringe counter design, and overall compatibility with the alignment system, none of them appears unsurmountable.

Furthermore, there is very interesting geophysical knowledge¹⁵ to be gained from the measurements of earth strains caused by local or teleseismic sources. Measurements in the 10^{-11} range have not been achieved before over such long distances and would open a new field of investigation.

A hint of the sensitivity that can be achieved with the present system¹⁶ is illustrated in the recording of Fig. 17. In this case, the image of the alignment laser from a Fresnel target, situated roughly 100 meters away, was detected and recorded for several hours before, during, and after the April 26, 1968, Nevada underground nuclear test. The trace exhibits some "natural" very low-frequency noise, but superimposed on it one can see a higher frequency oscillation (~ 10 cycles per minute) starting roughly three minutes after the explosion (7:03 A. M.). This delay coincides very nicely with the "time-of-flight" of the disturbance from the test site to the San Francisco Bay Area.

Acknowledgements

We are grateful to our colleagues at SLAC for their helpful participation in the various programs discussed in this report. In particular, we would like to thank Dr. J. V. Lebacqz, Head of the Klystron Department, for supplying us with the graphs illustrating klystron performance and life.

References

1. W. B. Herrmannsfeldt and R. H. Miller, "A 45° Inflection System for the Stanford Two-Mile Accelerator," IEEE Trans. Nuc. Sci. NS-12 (No. 3), 842 (1965).
2. R. H. Helm, G. A. Loew, and W. K. H. Panofsky, Beam Dynamics, Chap. 7 of The Stanford Two-Mile Linear Accelerator, W. A. Benjamin, Inc., New York, N. Y. (to be published in 1968).
3. H. Brechna, K. E. Breymayer, K. G. Carney, H. DeStaebler, R. H. Helm, and C. T. Hoard, The Positron Source, Chap. 16, of The Stanford Two-Mile Linear Accelerator, W. A. Benjamin, Inc., New York, N. Y. (to be published in 1968).
4. J. Pine and H. DeStaebler, "Pulse Thermal Stresses in the Positron Radiator," SLAC-TN-66-31, Stanford Linear Accelerator Center, Stanford, California (July 1966).
5. E. V. Farinholt, R. H. Helm, H. A. Hogg, R. F. Koontz, G. A. Loew, and R. H. Miller, 1967, Progress Report on Beam Break-Up at SLAC, Sixth International Conference on High Energy Accelerators, Cambridge Electron Accelerator, Cambridge, Massachusetts.
6. W. K. H. Panofsky and M. Bander, 1968, Rev. Sci. Instr., 39, No. 2, 206.
7. G. A. Loew, 1967, IEEE Transactions on Nuclear Science, NS-14, No. 3, 529.
8. Z. D. Farkas, C. J. Kruse, G. A. Loew, and R. A. McConnell, 1967, IEEE Transactions on Nuclear Science, NS-14, No. 3, 223-228.
9. J. Murray, SLAC, Private Communication.
10. O. H. Altenmueller, R. Larsen, G. A. Loew, 1964, Rev. Sci. Instr., 35, 438.
11. O. H. Altenmueller and G. A. Loew, 1965, Design and Applications of RF Deflecting Structures at SLAC, Fifth International Conference on High Energy Accelerators, Frascati, Italy.
12. Ph. Bernard, H. Lengeler, R. Romyn, and V. Vaghin, 1967, Experimental Breakdown Study of CERN Deflecting Structures, CERN/D. Ph. II/SEP 67-6.
13. H. Hahn, B. N. L., Private Communication.
14. W. B. Herrmannsfeldt, SLAC Alignment System, 1966 Linear Accelerator Conference, Los Alamos, New Mexico, October 3-7, 1966.
15. Proposal for the Development of a Six-Kilometer-Light-Path Optical Interferometer for the Study of Earth Strains From Local and Teleseismic Sources, Stanford Linear Accelerator Center and the Department of Geophysics, Stanford, California, November, 1967.
16. W. B. Herrmannsfeldt and J. J. Spranza, SLAC, Private Communication.

DISCUSSION

LEWIS, AECL: Do you have any statistics on the failure of klystrons? What are the most common causes?

NEAL, SLAC: The causes of failure have varied from one supplier to another. We have three separate suppliers including SLAC. With one manufacturer, the dominant cause has been window failure. In the case of another, it was the development of gassiness in the tubes. In the case of the third supplier, it was the development of instabilities. There is no single cause and even with a single manufacturer, the causes vary from time to time.

WARD, AECL: How many times have you had all units functional on the system, and do you have any statistics about the number of units out at any one time?

MILLER, SLAC: I am not sure that all klystrons have been functional at one time but fairly often we have only several which are not functional. In general there are always a number undergoing routine maintenance such as "tuning the pulse" line, and the operator routinely turns klystrons over to the maintenance people for "checkout". I guess that on the average 5 to 10 of the 245 klystrons are truly out of commission and are not out just for routine maintenance.

FEATHERSTONE, CERN: With regard to your remarks about difficulties of gassiness with one manufacturer: will all of these klystrons have built-in ion pumps?

MILLER, SLAC: It is the choice of the manufacturer. I believe that RCA is the only one incorporating ion pumps. It is the opinion of our klystron group that if there are serious problems, the small appendage-type ion pumps won't handle them. They may be more useful as diagnostic instruments than as an actual pump.

FEATHERSTONE, CERN: From your talk it sounded as though the first task of the control computer was to remove a defective klystron and plug another in.

MILLER, SLAC: What I meant was, if one klystron trips off several times, the computer will put another on the line. We always have klystrons on standby except on some high energy runs where we have had bad luck.

FEATHERSTONE, CERN: Are the ones on standby pulsing but pulsing at the "wrong time"?

MILLER, SLAC: Yes. To put them on line the pulsing is just shifted to the correct time to accelerate.

FEATHERSTONE, CERN: Will this computer be independent of the computer working in the beam switchyard?

MILLER, SLAC: Yes, initially. Eventually there may be a link between them.

TUNNICLIFFE, AECL: Have you any statistics of the total accelerator component failure rate in comparison with the klystron failure rate?

NEAL, SLAC: I am not sure but I believe the total number of faults is dominated by klystron modulator station faults. Many of these are recycling faults. The modulators momentarily kick out and then there is an automatic system which puts them through a "cycle" and then returns them to the line. I would say that klystron-modulator station faults exceed by 3 or 4 any other component or system. On the other hand, as Miller pointed out, this is responsible for a very small fraction of the time the beam is off.

WATERTON, AECL: When a klystron is out of service, do you do anything special to prevent the unexcited tank from absorbing energy from the beam?

MILLER, SLAC: No. About all you can do is detune the tank and we don't have facilities for doing that on individual sections.

BRAMHAM, CERN: I would like to ask about the improved klystrons. They give 30 megawatts output with the same voltage. What is the main difference and why didn't you make klystrons like that before?

MILLER, SLAC: It is a matter of optimizing all parameters, adjusting the drift tube lengths, drift tube diameters, cavity Q's and cavity frequencies, and especially the magnetic field configuration.

DOME, CERN: Is the capture section of the second injector similar to the capture section at the beginning of the accelerator?

MILLER, SLAC: Yes, except that the gun is off the axis and there is a bending magnet. The intent is to have exactly the same structure.

DOME, CERN: I suppose the effect on the main beam is negligible?

MILLER, SLAC: That's right.

HARVEY, AECL: Can you say something about your alignment experience? You have a very sensitive system for detecting misalignment. Have you found the structure to be stable? Have you done any realignment since the initial installation?

MILLER, SLAC: We realign about twice a year. The structure has been very stable with one striking exception. We had one region of the accelerator that for a period of several months appeared to move about 1 mil per day. We were quite upset about this. It moved about 100 mils but seems to have stopped now. Aside from that, the structure

DISCUSSION CONTINUED

has been very stable. We do not see alignment effects on earthquakes; at least not after the earthquake is over. We have had only minor earthquakes.

The alignment system is accurate to several mils. However, the effective rf field misalignment is much larger and we do not understand this. Each section of the accelerator gives a transverse impulse that in some cases corresponds to a misalignment of 1/4 inch. We check such a section three different ways. Externally, such a section appears to be aligned but we still have these effects of transverse impulse produced by the rf field.

TABLE 1
ACCELERATOR OPERATIONS

	1st Qtr. FY 1968	2nd Qtr. FY 1968	3rd Qtr. FY 1968	Year to Date FY 1968
I. Physics Beam Hours				
1. Machine Physics	130	82	74	286
2. Particle Physics	<u>909</u>	<u>735</u>	<u>958</u>	<u>2,602</u>
Total Physics Beam Hours	1,039	817	1,032	2,888
II. Non-Physics Hours				
1. Scheduled Maintenance	136	98	70	304
2. Accelerator Failure	109	85	78	272
3. BSY or End Station Equip. Failure	54	49	29	132
4. Search or Shut-Down	43	18	12	73
5. Accelerator Tune-Up	97	64	59	220
6. BSY and End Station Equip. Tune-Up	47	43	36	126
7. Beam Off-Accel. Physics Request	23	21	18	62
8. Beam Off-Research Area Request	73	69	45	187
9. Other	<u>3</u>	<u>---</u>	<u>---</u>	<u>3</u>
Total Non-Physics Hours	585	447	347	1,379
III. Total Manned Hours	1,624	1,264	1,379	4,267
IV. Experimental Hours				
1. Machine Physics	164	104	103	371
2. Particle Physics				
a. End Station A	730	593	785	2,108
b. End Station B	658	524	691	1,873
c. End Station C	<u>110</u>	<u>45</u>	<u>495</u>	<u>650</u>
Sub-Total Particle Physics	1,498	1,162	1,971	4,631
Total Experimental Hours	1,662	1,266	2,074	5,002
V. Total Klystron Hours	334,859	265,745	306,463	907,067
VI. Klystron Failures	27	23	20	70

TABLE 2
ACCELERATOR OPERATIONS
(EXPRESSED AS PERCENT OF TOTAL MANNED HOURS)

	1st Qtr. FY 1968	2nd Qtr. FY 1968	3rd Qtr. FY 1968	Year to Date FY 1968
I. Physics Beam Hours				
1. Machine Physics	8.0	6.5	5.4	6.7
2. Particle Physics	<u>56.0</u>	<u>58.1</u>	<u>69.4</u>	<u>61.0</u>
Total Physics Beam Hours	64.0	64.6	74.8	67.7
II. Non-Physics Hours				
1. Scheduled Maintenance	8.4	7.8	5.1	7.1
2. Accelerator Failure	6.7	6.7	5.6	6.4
3. BSY or End Station Equip. Failure	3.3	3.9	2.1	3.1
4. Search or Shut-Down	2.6	1.4	0.9	1.7
5. Accelerator Tune-Up	6.0	5.1	4.3	5.2
6. BSY and End Station Equip. Tune-Up	2.9	3.4	2.6	2.9
7. Beam Off-Experimenters Request	<u>6.1</u>	<u>7.1</u>	<u>4.6</u>	<u>5.9</u>
Total Non-Physics Hours	36.0	35.4	25.2	32.3
III. Total Manned Hours	100%	100%	100%	100%

TABLE 3
KLYSTRON USAGE AND FAILURES

Dates	Operating Hours		Overall			
			Quarter		Cumulative	
	Quarter	Cumulative	Number	Mean Age at Failure	Number	Mean Age at Failure
To 6/30/66	118,000	156,000	17	234	39	256
To 9/30/66	127,000	283,000	14	594	53	350
To 12/31/66	176,000	459,000	23	1070	76	575
To 3/31/67	228,000	687,000	28	1670	104	860
To 6/30/67	303,000	990,000	26	2166	130	1130
To 9/30/67	335,000	1,325,000	27	2881	157	1433
To 12/31/67	265,500	1,590,500	23	3833	180	1739
To 3/31/68	310,000	1,900,500	20	4487	200	2013

TABLE 4
LOLA IV RF SEPARATOR STRUCTURE

Mode family		HEM ₁₁
Phase shift per cavity		$2\pi/3$
Periodic length (cm)	d	3.5
Disk thickness (inches)	t	0.230
Cavity ID (inches)	2b	4.5805
Iris aperture diameter (inches)	2a	1.7670
Suppressor holes diameter (inches)	2p	0.750
Suppressor holes offset (inches)	c	1.457
Steel ball height (inches)	h	1.7440
Ball diameter (inches)	2r	2.2503
Disk hole edge radius (inches)	ρ	0.1215
Flatness (inches)	s	0.031
Disk thickness (inches)	t	0.230
Outside diameter (inches)		5.417
Coupler dimensions:		
Disk hole diameter (inches)	2a	1.7670
ID (inches)	2b	4.5010*
Cutoff hole length (inches)		2.750
Waveguide iris aperture (inches)	i	1.350
Length of section including both couplers (cm)	l	364.0
Cold test frequency (75°F, air) (MHz)	f	2856.2
Quality factor	Q	12,100
Relative group velocity	v_g/c	-0.0189
Attenuation per meter (NP/m)	α	0.131
Attenuation (NP)	αl	0.477
$(1 - e^{-\alpha l})\sqrt{2\alpha l}/\alpha l$		0.775
Deflection obtained with K ⁺ , π^+ beam (MeV/ \sqrt{MW})	$p_{\perp c}/\sqrt{P_0}$	5.9
$E_0/\sqrt{P_0}$ (MV/m/ \sqrt{MW})	\sqrt{Z}	2.05
Transverse shunt impedance (M Ω /m)	$r_{0,T}$	16
Maximum operating klystron power (MW)	P_0	25
Typical operating klystron power (MW)	P_0	22

* For best match, iris lips had to be bent in; hence, in retrospect 2b_{CPL} should have been made smaller (~ 4.495 inches).

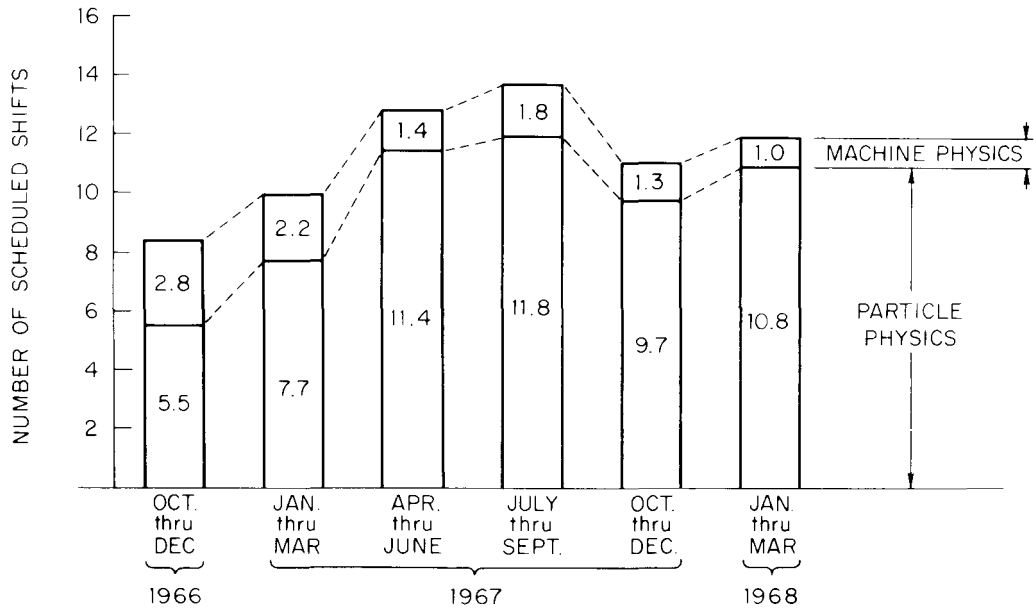

Figure 1. Scheduled shifts per week.

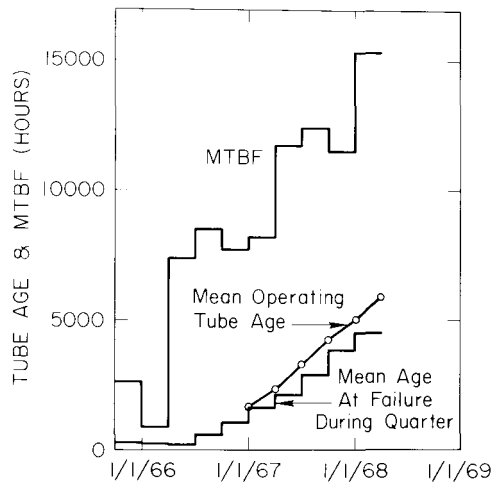

Figure 2. Tube age and mean time between failures (all vendors).

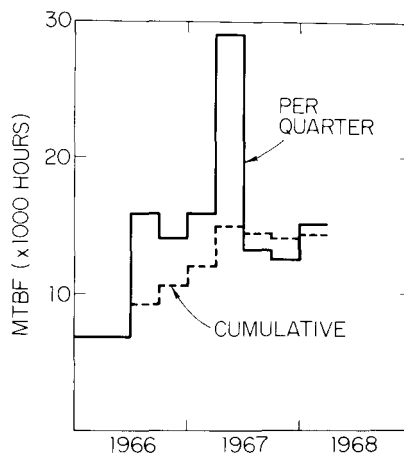

Figure 3. Mean time between failures (omitting least successful vendor).

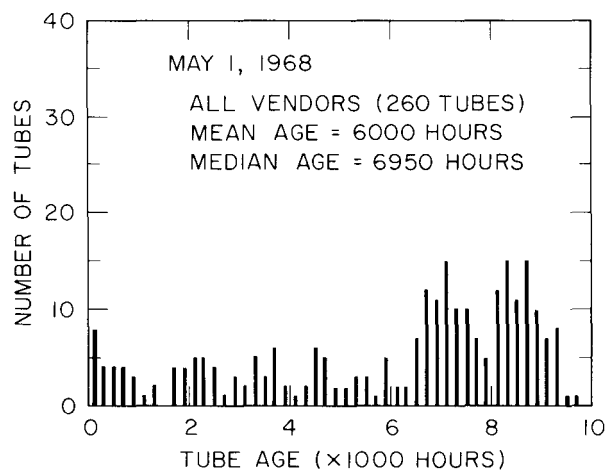

Figure 4. Klystron age distribution in 200-hour increments.

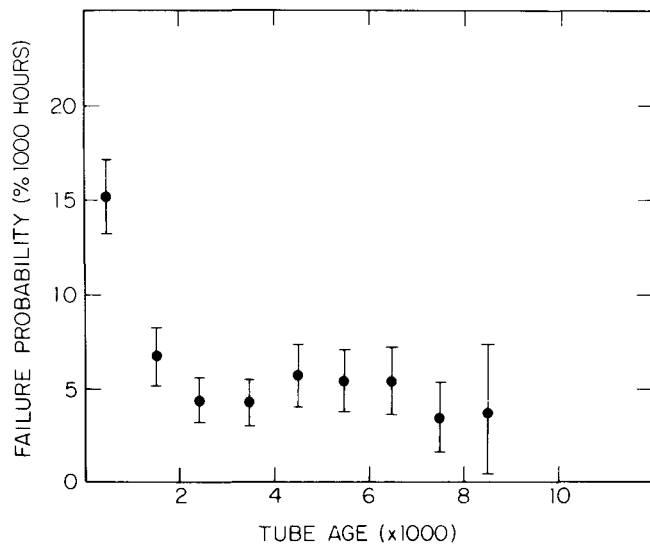

Figure 5. Klystron failure probability per unit time.

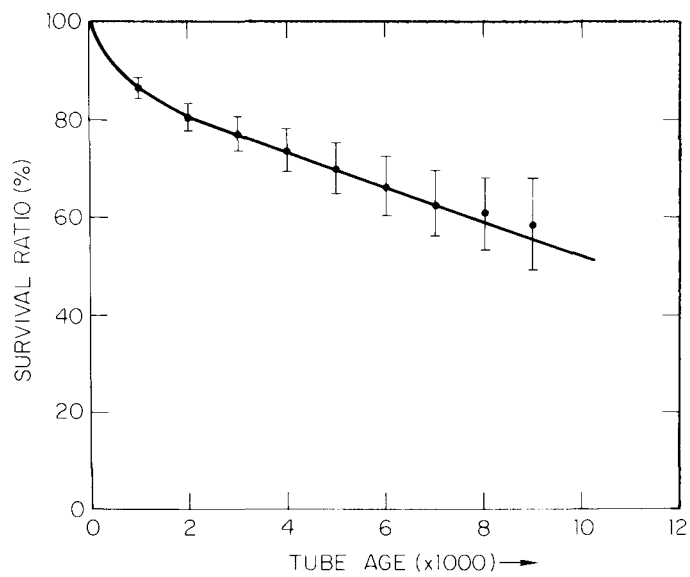

Figure 6. Klystron survival curve.

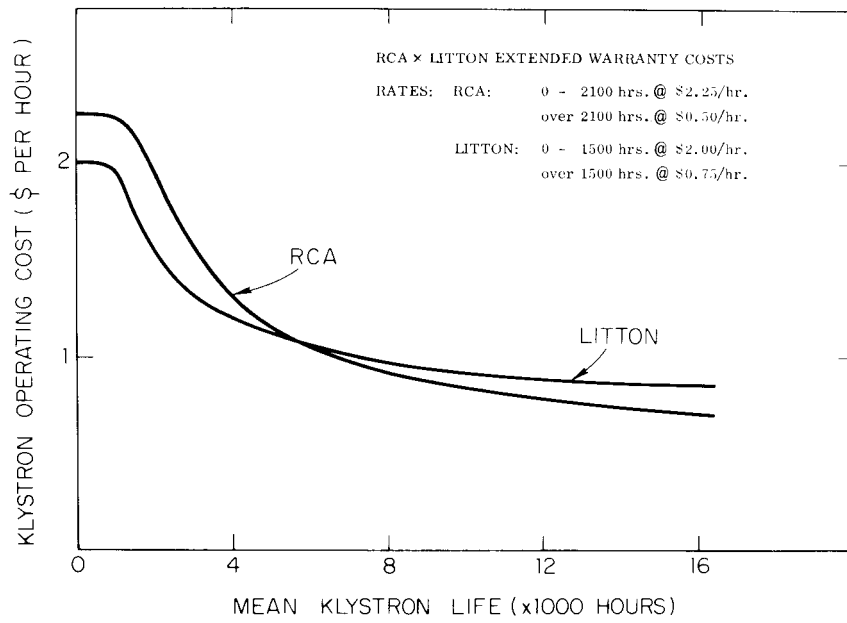

Figure 7. Klystron operating costs per hour under extended warranty contracts.

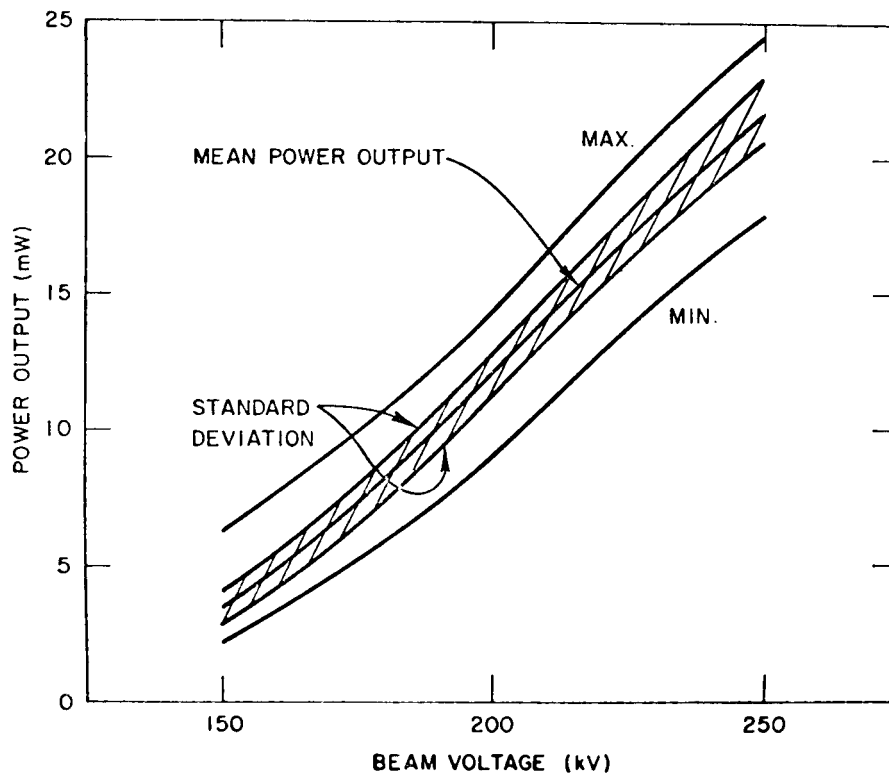

Figure 8. Power output of initially installed tubes (November 1966) versus beam voltage.

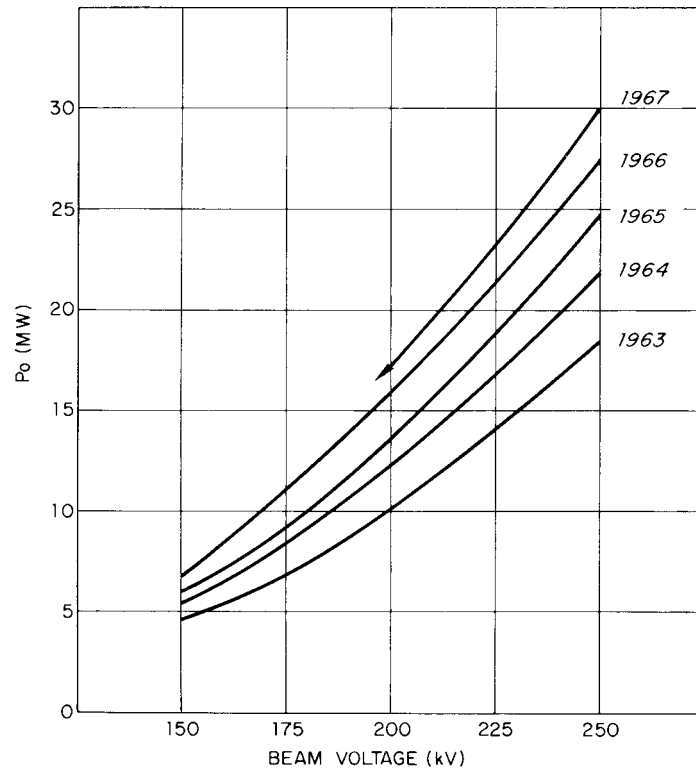

Figure 9. SLAC klystron performance versus beam voltage showing improvements in efficiency.

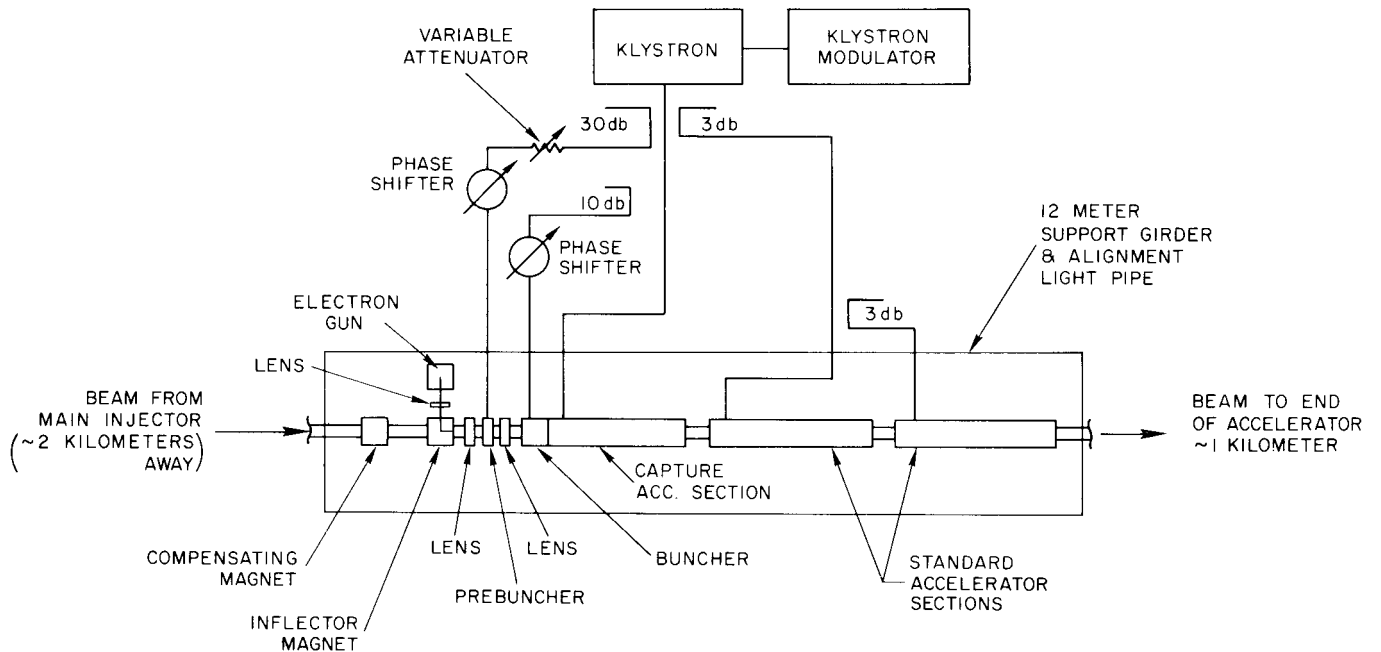

Figure 10. Second injector layout.

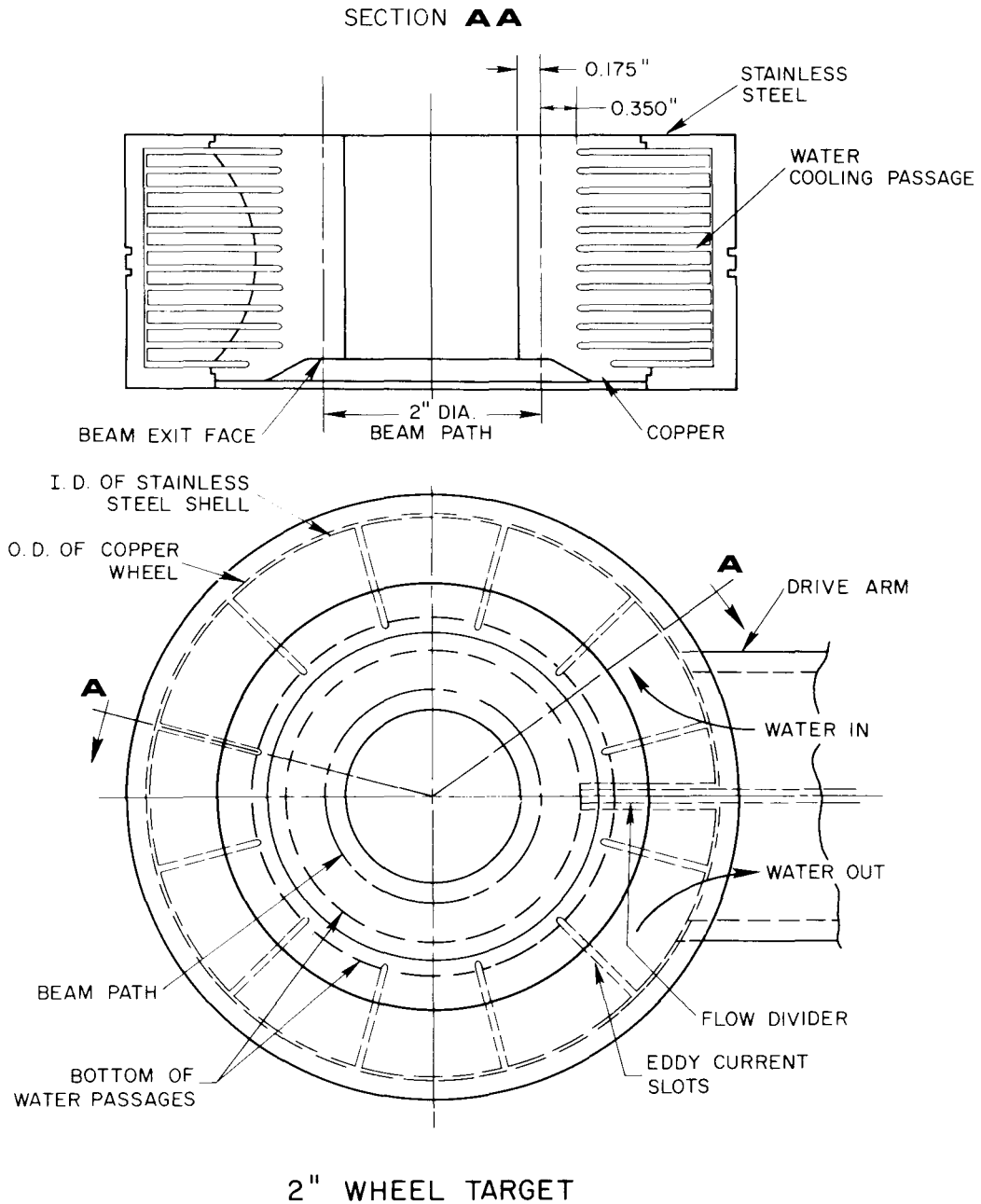

Figure 11. Simplified drawing of 2-inch positron target.

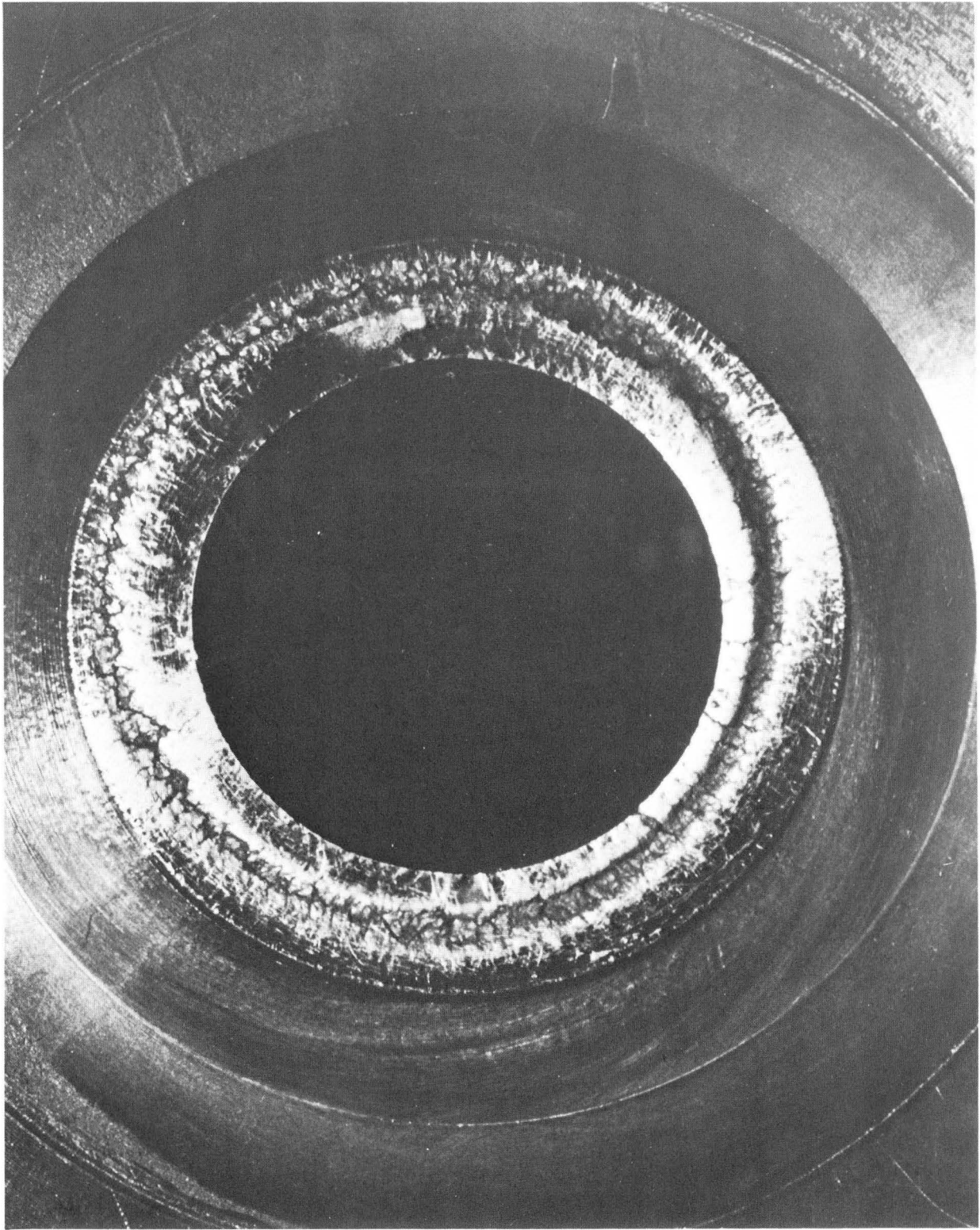

Figure 12. Beam damage on 2-inch positron target.

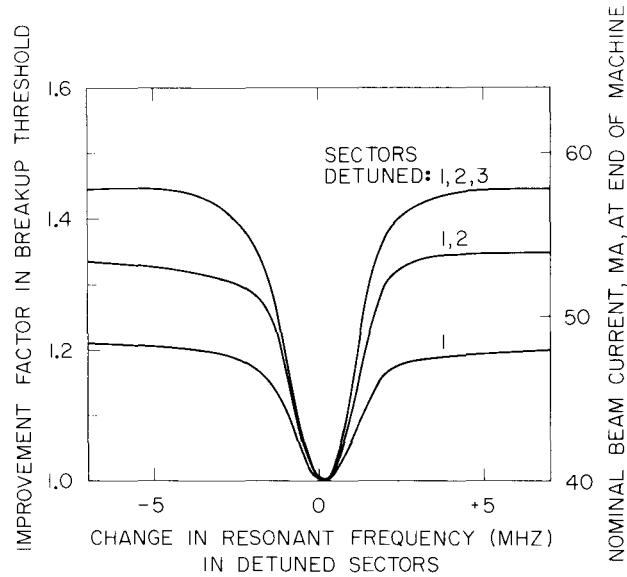

Figure 13. Predicted beam breakup threshold improvement at SLAC versus frequency change in HEM_{11} mode in sectors 1, 2 and 3.

Final energy: 18 GeV. Pulse length: $1.6 \mu\text{sec}$. Focusing: Sectors 1 through 6, 40-ft. spaced quadrupole singlets ($\lambda_{\beta} \approx 150 \text{ m}$); sectors 7 through 30, sector doublets ($\lambda_{\beta} \approx 500 \text{ m}$).

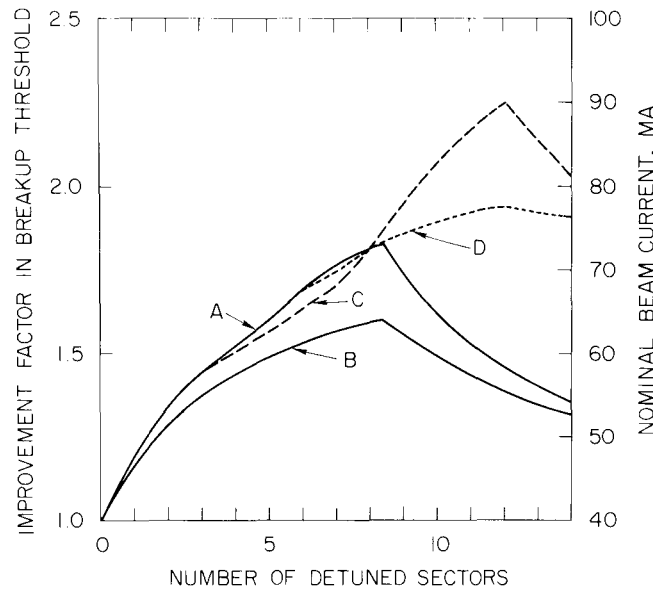

Figure 14. Beam breakup threshold improvement factor at SLAC versus number of detuned sectors. Accelerator conditions same as in Fig. 13.

Curve A: $\Delta f = +4 \text{ MHz}$ in all detuned sectors.

Curve B: $\Delta f = +2 \text{ MHz}$ in all detuned sectors.

Curve C: $\Delta f_1 = +4 \text{ MHz}$ in sectors 1, 2, 3; $\Delta f_2 = +2 \text{ MHz}$ in remaining detuned sectors.

Curve D: $\Delta f_1 = +4 \text{ MHz}$ in sectors 1 through 6; $\Delta f_2 = +2 \text{ MHz}$ in remaining detuned sectors.

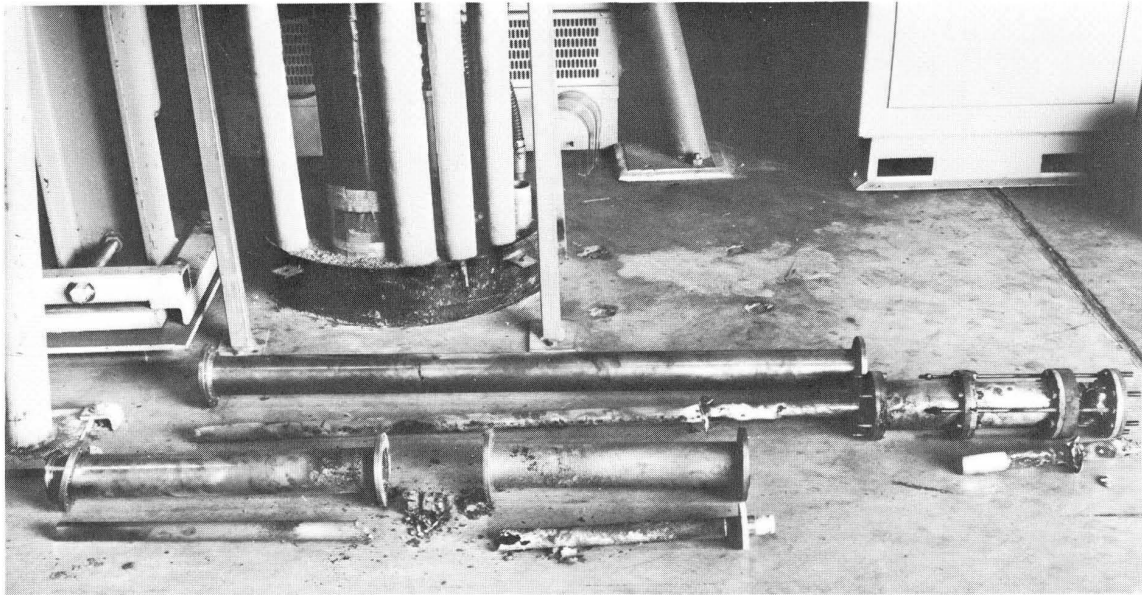

Figure 15. Severely burned elements of damaged main drive line (April 1968).

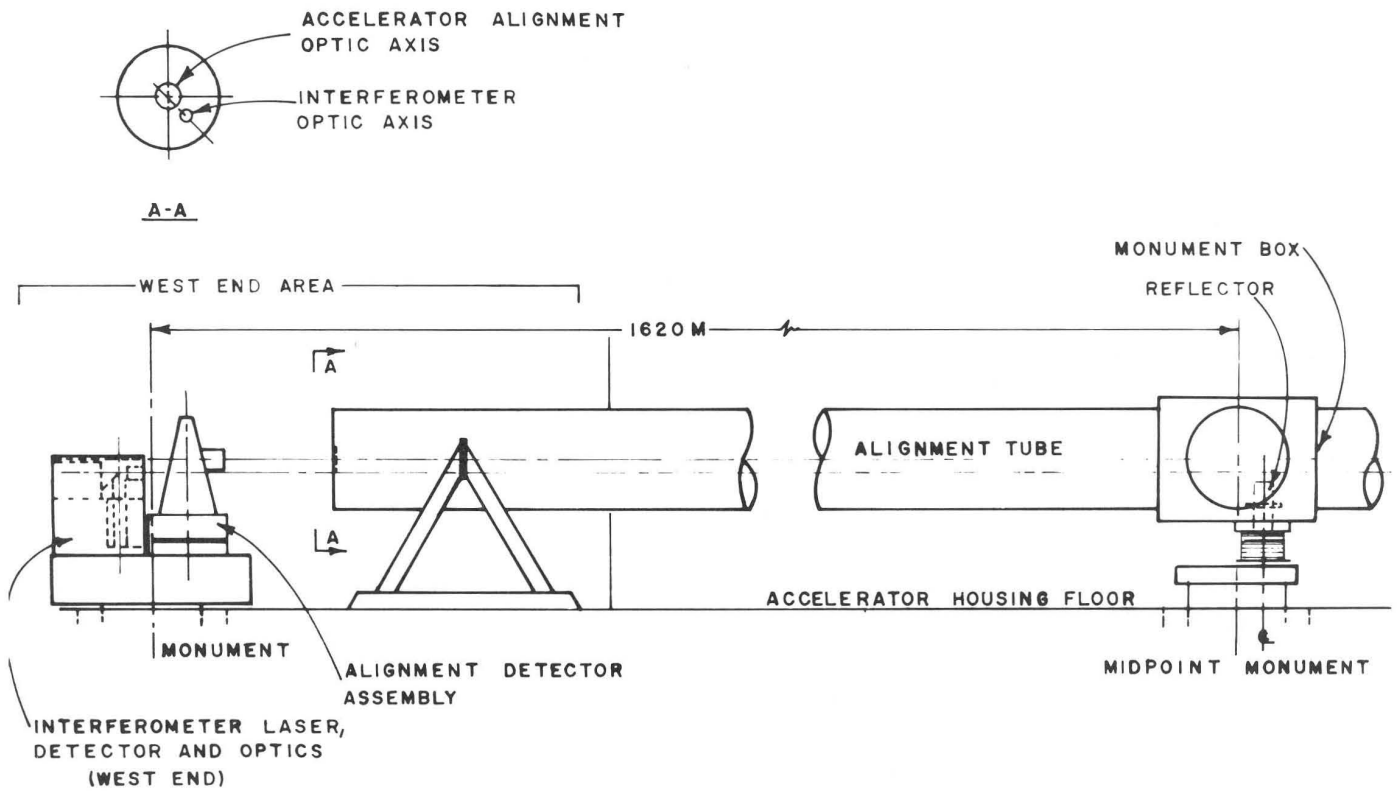

Figure 16. Proposed interferometer installation in two-mile linear accelerator light pipe.

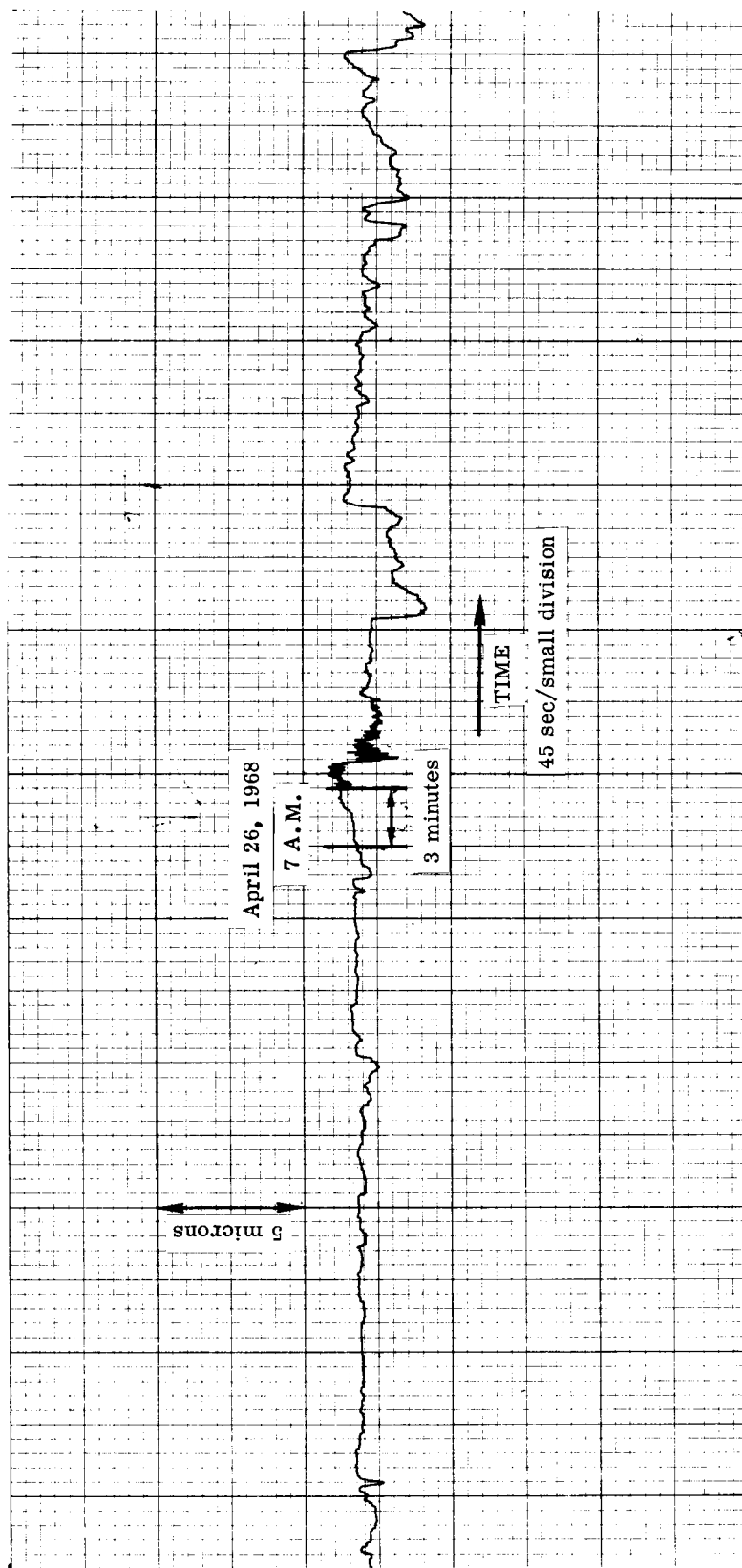

Figure 17. Recorder trace of SLAC laser alignment detector output taken on April 26, 1968.

In this case, the laser at the end of the accelerator was being imaged by a Fresnel target (No. 28-9), roughly 200 meters upstream, giving a magnification of ~ 15 .