

OPERATION OF THE BNL 200 MeV LINAC\*

K. Batchelor  
Brookhaven National Laboratory  
Upton, New York

Introduction

The BNL 200 MeV Proton Linear Accelerator(1) accelerated a beam to full energy for the first time in November, 1970. At this time operation was possible only from ten local control stations situated throughout the machine complex. In the ensuing year installation of the Data Acquisition Control and Display System (DACADS) and remote turn on controls for the machine systems allowed operation to be transferred to the Injector Control Room and for early injection studies to be made during the latter part of this period. In October 1971 the High Energy Physics Program was started with the new injector in operation and accurate machine operational data is available from that time. This paper will therefore deal largely with the operation of the Linac for the period from October 1, 1971 to August 31, 1972 at which time a major AGS failure caused an unscheduled shutdown of the AGS complex.

Overall Operation

For the purposes of fault logging the machine has been divided into a number of sub-divisions and hours lost and corresponding percentages for these lost hours as a function of the total time lost has been calculated on a month by month basis. The results of this analysis can be seen in Table I. It can be seen from this Table that the rf system accounted for the major part of the fault time (57.9%) and that the preinjector was the next most significant contributor (18.3%). However, the nature of the faults in these two areas was somewhat different in that 90 hours out of 125 hours lost due to preinjector faults were due to two major faults, an ion source failure and a failure of the drive shaft to the alternator in the Cockcroft-Walton generator dome; whereas the rf system failures generally were many failures of a shorter duration distributed throughout the nine rf stations. The lower percentages of lost time due to rf failure in October 1971 and March 1972 are clearly due to these major failures of the preinjector. Furthermore a series of power failures in November 1971 and a series of vacuum failures in newly installed interlocks resulted in a reduction of the rf fault percentage in July 1972. Figure 1 shows the overall operation percentages for the eleven month operational period. It can be seen that there has been a gradual increase in machine availability from 82% to 95% giving an overall operating percentage of 88% for the first year of operation. The 74 hours of time lost in March 1971 due to the preinjector drive shaft failure shows up as it was the only month where the percentage fell below 82%.

The average peak 200 MeV beam current and maximum peak 200 MeV beam current have also been recorded in Fig. 1. This shows a gradual increase in average and maximum current during the first six

months of operation followed by a period of operation at a fairly constant current level. This pattern is largely due to the demands of the AGS since during the first six month period various peak currents and pulse lengths were tried in an attempt to increase the output current from the AGS. The highest currents up to the maximum of 95 mA achieved in March 1971 were usually associated with an accelerator physics study period. For the past five months the current level has been held at an average of 55 mA peak for an 80  $\mu$ sec pulse length at which level the AGS has operated at between 4 and  $5.5 \times 10^{12}$  protons per pulse. The average peak current was intentionally lowered in August to reduce the voltage on the modulator output tubes which had been failing at a rate which caused some concern over the lack of spare tubes.

Preinjector Operation

Operation of the preinjector system has generally been very satisfactory. The number of arc-overs of the column and the high voltage set has been negligibly small since the addition of an extractor electrode in the source. Previously charge buildup on the column's electrodes for certain ion source parameters gave rise to a collapsing beam current and subsequent column arcing. The shaft breakage mentioned earlier was due to the poor mechanical properties of the electrically sound insulating material used to fabricate the shaft. A BNL built drive shaft made of G10 epoxy and a slow start for the drive motor has alleviated this problem. There is however need for routine maintenance of gear box and bearings used in this system and an alternate backup system is being considered. The ion source has generally operated reliably with only one failure occurring during a running period. Arc-overs initially caused some failure of the cathode power supply and the extractor power supply but protective circuitry and a reduction of arc-over rate has reduced this to a low level of incidence. Problems on the vacuum system will be discussed in a later section.

Low Energy Beam Transport System

Other than some early quadrupole pulser failures due to column arcing giving erroneous triggers there has been very little trouble with this system. The bunchers have operated reliably and consistently and have caused no major downtime.

Vacuum and Water Systems

These systems have generally run reliably with much of the downtime being caused by faulty metal seals in the High Energy Beam Transport and Brookhaven Linac Isotope Producer lines. These leaks were usually caused by beam heating of the pipe which gave rise to slight distortion of the seal flange. An improved seal design has eliminated this problem. The cavity vacuum and water systems have been extremely reliable with only tank #8 causing any loss of time. The problem

\*Work performed under the auspices of the U.S. Atomic Energy Commission

there was the fracture of the ceramic cups which preserve the vacuum for the rf pickup probes. Three of these have failed in tank 8 apparently due to rf heating or breakdown. On this tank the characteristic multipactor markings actually pass over the region where the probes are situated. In one operating period a vacuum interlock on each vacuum pump current was used to close the inter-tank isolating valves. It was found that during the course of a month there were sufficient minor current increases in individual pump currents to need frequent resetting of the tank valves which gave rise to 9 hours of lost time. The interlock has been changed so that two pumps at each end of each tank must act in unison for the valves to close. Normally it is possible to pump a cavity down and re-establish rf at full gradient in 3-4 hours.

The preinjector ion pumps have also given some loss of operating time. It was found that the pumps tend to develop whiskers after pumping for two to three months on the hydrogen load. These whiskers may be cleaned by spot-knocking with a power supply. However, after some six months the original elements bowed sufficiently to cause permanent shorts and require element replacements. Improved elements have been installed in the pumps used for the preinjector and the second backup vacuum manifold with two spare pumps has been installed so that maintenance and/or spot-knocking can be carried out whilst the machine is operational.

The main problems with the water system have been a mechanical failure of the cooling fan in the water tower and failure of tubular elements in a heat exchanger due to mechanical vibrations.

#### Controls

There has been no major failure in the control system and very little downtime has been recorded in this area. Occasionally chips fail on printed circuit boards but the problems are usually easy to locate and replacement of boards is easily accomplished. Furthermore it is always possible to return to a manual mode of operation if the computer or certain elements of the DACADS fail. The computer has been extremely reliable and due to the manual backup has not caused any downtime. It is routinely used to record all of the dc reference voltages sent to the various local servos and to record and analyze beam data as reported in the section on beam operation.

#### Magnets and Quadrupoles

The quadrupole pulsers and magnet power supplies have contributed only 3.67% of the fault time. Most of this time has been taken up in replacing faulty pulsers (~ 20 minutes) or fuses (~ 2-5 minutes) in the quadrupole pulsers. Many of the earlier faults occurred in the first two pulsers in the LEBT system where preinjector arcs have caused extraneous triggers to allow irregular SCR fixing with subsequent component failure. There have been beam steering problems which were at first thought to be due to a faulty quadrupole in tank #4 but electrical tests show the quadrupoles to be good and it is now thought that drift tube misalignment is the problem. A complete resurvey of the drift tubes is planned for the next major shutdown.

Meanwhile good beam transmission is possible only by running with quadrupole 4-29 turned off and with appropriate current changes in adjoining quadrupoles. With these exceptions all quadrupoles in the machine are operating at design values.

#### RF System

As expected the radio-frequency system has contributed the major part of the machine downtime. Figure 2a is a block schematic of the rf system showing its component parts each of which has contributed to downtime. The 60 kV power supply contributed 5% of the rf system fault time with the faults being breakdown of the high voltage connector and water seepage through the upper seal causing breakdown of one unit. The 2.7% contribution of the capacitor bank was for ignitron and crowbar unit replacement. The 12 in. transmission line components have been extremely reliable with only 3.4% of the downtime, this being due to arcing in the sliding sections of the hybrid phase shifter. After some early failures in the low level electronics due to high voltage arc-overs, the addition of protective circuitry in the charge control amplifier has increased its reliability to the point where it is a minor contributor to failure (6.5%). The driver system contributed 8.8% of the rf system downtime with the screen modulator being the major contributor. The 7835 system contributed 8.6% with tube changes and repairs to spring rings and contact fingers in the 7835 cavity being the major area of trouble.

The modulator was by far the major contributor to downtime in the rf system contributing 65% of the rf system faults and over 40% of all machine failures. Figure 2b is a block schematic of the modulator system showing the various tubes and power supplies there. The main problem has been the 8618 output tube, three of which make up the modulator output stage. In operation these tubes have been prone to outgas giving rise to a high voltage plate arc which transfers to the grid cathode region and causes the cathode power supply circuit breaker to trip on overcurrent. This requires entry to the high voltage area of the modulator in order to reset the breaker. Furthermore the energy in the grid caused damage to that structure and ultimately tube failure. Addition of spark plugs grid to cathode eliminated the grid damage and pre-conditioning of the 8618 tubes in the 10th rf system has reduced the outgassing to a minimum. However, a weak design of the support for the filaments allows early lifetime failures due to breakage of a tungsten filament tie-wire. The manufacturer is currently testing an alternative tie-wire material.

Other than these failures the overall radio-frequency system has performed extremely well. The fast amplitude and phase control loops have, in general, operated well holding the rf gradient during the typical 55-60 mA beam current pulse to within  $\pm 0.3\%$  and  $\pm 0.3$  degrees respectively. Five 7835 tubes have failed, four due to grid cathode shorts and one due to end of useful emission. This latter tube failed after 8123 hours of operation which is a relatively short lifetime for a thoriated tungsten filament and suggests some filament processing problems. The other four tubes all failed with between 6000 and

7000 filament operating hours on them.

#### Power Failures

Power dips and power failures due to lightning and other causes have contributed significantly to machine downtime with an overall percentage of 5.83%.

#### Beam Measurements

Details of the beam diagnostic equipment will be discussed in another paper to be presented at this conference (2) so I will not describe it here. Emittance measurements on the 750 keV beam at the entrance to the first accelerating cavity may be seen in Fig. 3. The measurements were made with one buncher in operation and for a beam current of 150 mA. It can be seen that the 90% emittance values are 19.6 cm mrad in both planes. The corresponding 10 MeV data shown in Fig. 4 gives emittances of 8.9 cm mrad in the horizontal and 9.0 cm mrad in the vertical planes for the 95 mA accelerated beam current. This gives an overall emittance growth in tank #1 of the order of two which is in excellent agreement with the actual data given in Reference 3. Reduction of the input current to give 55 mA, 10 MeV beam current resulted in a 90% emittance value of  $\sim 11$  cm mrad which is consistent with a linear relation between current and emittance. The 10 MeV emittance value showed a corresponding reduction.

Apparatus to make similar emittance measurements at 200 MeV has only recently been installed so no data is available. Data from secondary emission monitors which give beam profiles in the High Energy Beam Transport line suggests that the 200 MeV emittance for a 55 mA beam current is between 1.2 and 1.5 cm mrad which is consistent with little or no growth in the machine beyond the 10 MeV point.

The momentum spread and the change in average momentum during the 100  $\mu$ sec beam pulse due to variations in rf amplitude and phase are typically  $\sim 0.5\%$  and  $0.3\%$  respectively. However, recent field shaping in tanks 1 and 2 and a reduction in all other cavity field gradients to give a variation in  $\phi$ s along the machine(4) has improved these figures to the point where a new momentum analysis system is required in order to measure these quantities.

#### Other Uses Of The Linac

In addition to providing beam for the AGS the Linac can provide pulses for isotope production in commercial quantities. The Brookhaven Linac Isotope Producer (BLIP) is now virtually a complete installation. Early measurements to determine production rates for various material, target testing, heat transfer, etc., work is well underway on Iron 52, high purity Iodine 123 and Xenon 127. Considerable work on the processing of these materials to make them suitable for clinical use has been carried out by the Department of Applied Science at BNL.

In a spur line to the BLIP facility there is a rabbit which allows for irradiations by the

Radio-Chemistry Group at 92 MeV and 115 MeV on an alternate pulse basis with 200 MeV operation. These studies involve the use of protons to produce neutron rich isotopes. Some new isotopes have been discovered such as Hafnium 184 and Tungsten 190. A study of high spin isomers resulted in the discovery of a  $-\frac{37}{2}$  spin resonance in Hafnium 182 M.

A small continuing program on the Bio-Medical applications of 200 MeV protons is also underway.

#### Conclusion

In general the first year of operation of the Linac has been extremely successful. All of the design goals have been achieved though operational levels have normally been reduced to suit the needs of the AGS and other users. The increasing use of the computer as a monitor and diagnostic tool has greatly eased the burden of operation.

#### Acknowledgements

It is impossible to include the names of all the people who have contributed in no small way to the success of this project. My thanks are due to all of the Linac engineers and technicians who worked through difficult times to make it all possible. The operating technicians whose careful recording of operational data made the analysis possible are also to be commended.

#### References

1. G.W. Wheeler, "Status of the BNL 200 MeV Injector Linac" Proc. 1970 Proton Linear Accelerator Conference, NAL Sept.-Oct. 1970.
2. N. Fewell and R. Witkover, "Beam Diagnostics at the BNL 200 MeV Linac" *ibid.*
3. K. Batchelor, R. Chasman, N. Fewell and R. Witkover, "The Dependence of Transverse Emittance Growth on the Quadrupole Focussing Strength in the Brookhaven 200 MeV Linac" *ibid.*
4. K. Batchelor, R. Chasman and N. Fewell, "Calculations and Measurements in Reduction of the Energy Spread and the Variation in Mean Energy of the 200 MeV Linac Beam at Brookhaven" *ibid.*

| MACHINE FAILURES RESULTING IN LOSS OF BEAM TIME TO AGS OR BLIP  |                     |                     |                     |                     |                     |                      |                     |                     |                     |                    |                     |        |  |              |  |        |  |
|---|---------------------|---------------------|---------------------|---------------------|---------------------|----------------------|---------------------|---------------------|---------------------|--------------------|---------------------|--------|--|--------------|--|--------|--|
| SYSTEM  | 1971                |                     |                     | 1972                |                     |                      |                     |                     |                     |                    |                     |        |  |              |  |        |  |
|   | OCT                 | NOV                 | DEC                 | JAN                 | FEB                 | MAR                  | APR                 | MAY                 | JUN                 | JUL                | AUG                 |        |  |              |  |        |  |
| PRE-INJECTOR  | 18.50 HRS<br>23.09% | 4.50 HRS<br>5.80%   | 6.75 HRS<br>10.48%  | 8.00 HRS<br>10.34%  | 4.00 HRS<br>6.55%   | 74.00 HRS<br>44.90%  | 0                   | 0.13 HRS<br>0.65%   | 4.83 HRS<br>13.00%  | 2.05 HRS<br>10.43% | 3.00 HRS<br>9.23%   |        |  |              |  |        |  |
| LOW ENERGY BEAM TRANSPORT   | 0.10 HRS<br>0.12%   | 0.50 HRS<br>0.64%   | 0                   | 0                   | 0.50 HRS<br>0.82%   | 0                    | 0                   | 0                   | 0.40 HRS<br>1.08%   | 0                  | 0                   |        |  |              |  |        |  |
| VACUUM AND WATER SYSTEMS  | 13.00 HRS<br>16.23% | 15.23 HRS<br>19.63% | 9.00 HRS<br>13.82%  | 6.17 HRS<br>7.93%   | 12.00 HRS<br>19.65% | 8.05 HRS<br>14.88%   | 9.72 HRS<br>19.00%  | 3.63 HRS<br>18.11%  | 3.67 HRS<br>9.88%   | 9.45 HRS<br>48.09% | 3.90 HRS<br>12.00%  |        |  |              |  |        |  |
| CONTROLS  | 0.92 HRS<br>1.15%   | 0                   | 0.17 HRS<br>0.26%   | 0.50 HRS<br>0.64%   | 0                   | 1.50 HRS<br>2.82%    | 0                   | 0                   | 0.17 HRS<br>0.46%   | 0                  | 0                   |        |  |              |  |        |  |
| MAGNETS AND QUADRUPOLES   | 5.50 HRS<br>6.87%   | 5.92 HRS<br>7.67%   | 0.67 HRS<br>1.02%   | 3.50 HRS<br>4.52%   | 0.50 HRS<br>0.82%   | 4.65 HRS<br>7.82%    | 0.7 HRS<br>1.33%    | 0.7 HRS<br>1.33%    | 2.33 HRS<br>6.27%   | 0                  | 1.82 HRS<br>5.60%   |        |  |              |  |        |  |
| R.F. SYSTEM   | 36.67 HRS<br>45.77% | 35.42 HRS<br>45.66% | 43.67 HRS<br>67.70% | 58.92 HRS<br>75.93% | 39.55 HRS<br>64.78% | 72.35 HRS<br>133.90% | 39.58 HRS<br>77.38% | 15.78 HRS<br>43.11% | 25.75 HRS<br>72.33% | 7.40 HRS<br>20.83% | 22.57 HRS<br>64.45% |        |  |              |  |        |  |
| POWER FAILURES & MISCELLANEOUS  | 5.42 HRS<br>6.77%   | 16.00 HRS<br>20.65% | 4.33 HRS<br>6.72%   | 0.50 HRS<br>0.64%   | 4.50 HRS<br>7.37%   | 5.25 HRS<br>8.31%    | 1.68 HRS<br>3.19%   | 0.33 HRS<br>0.91%   | 0                   | 0.75 HRS<br>2.08%  | 1.21 HRS<br>3.72%   |        |  |              |  |        |  |
| 1. ION SOURCE CHANGE RESULTED IN 16 HOURS OF LOST BEAM OPERATION.<br>2. POWER FAILURES RESULTED IN A TOTAL OF 15 HOURS IN LOST TIME.<br>3. MAJOR FAILURE OF PRE-INJECTOR DRIVE SHAFT RESULTED IN A LOSS OF 76 HOURS OF BEAM TIME.<br>4. NEW VACUUM INTERLOCKS CAUSED FREQUENT INTER-TANK VALVE CLOSURES CAUSING 7.5 HOURS LOST BEAM TIME. |                     |                     |                     |                     |                     |                      |                     |                     |                     |                    |                     |        |  |              |  |        |  |
| MONTH   | OCT 71              | NOV 71              | DEC 71              | JAN 72              | FEB 72              | MAR 72               | APR 72              | MAY 72              | JUN 72              | JUL 72             | AUG 72              | TOTAL  |  |              |  |        |  |
| HOURS SCHEDULED   | 504                 | 432                 | 388                 | 496                 | 505                 | 595                  | 690                 | 392                 | 728                 | 203                | 680                 | 5613   |  |              |  |        |  |
| HOURS OPERATIONAL   | 424                 | 354.5               | 323.5               | 418.5               | 444                 | 430                  | 639                 | 372                 | 689.5               | 183.5              | 647.5               | 4926   |  |              |  |        |  |
| OPERATING PERCENTAGE  | 84.0                | 82.3                | 83.7                | 84.5                | 87.9                | 72.3                 | 92.6                | 94.9                | 94.7                | 90.3               | 95.2                | 88.0   |  |              |  |        |  |
| OVERALL SYSTEM FAILURE TIMES  | PRE-INJECTOR        |                     |                     | L.E.B.T.            |                     | VACUUM & WATER       |                     | CONTROLS            |                     | MAGNETS & QUADS    |                     | R.F.   |  | POWER & MISC |  | TOTAL  |  |
| HOURS   | 125.76              |                     |                     | 1.50                |                     | 93.82                |                     | 3.36                |                     | 25.23              |                     | 397.66 |  | 40.07        |  | 687.40 |  |
| PERCENTAGE  | 18.29               |                     |                     | 0.22                |                     | 13.65                |                     | 0.49                |                     | 3.67               |                     | 57.85  |  | 5.83         |  | 100.00 |  |

Table I. Machine Failures Resulting in Loss of Beam Time to AGS or BLIP.

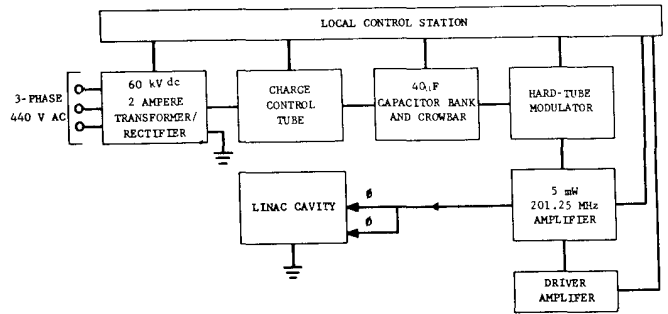
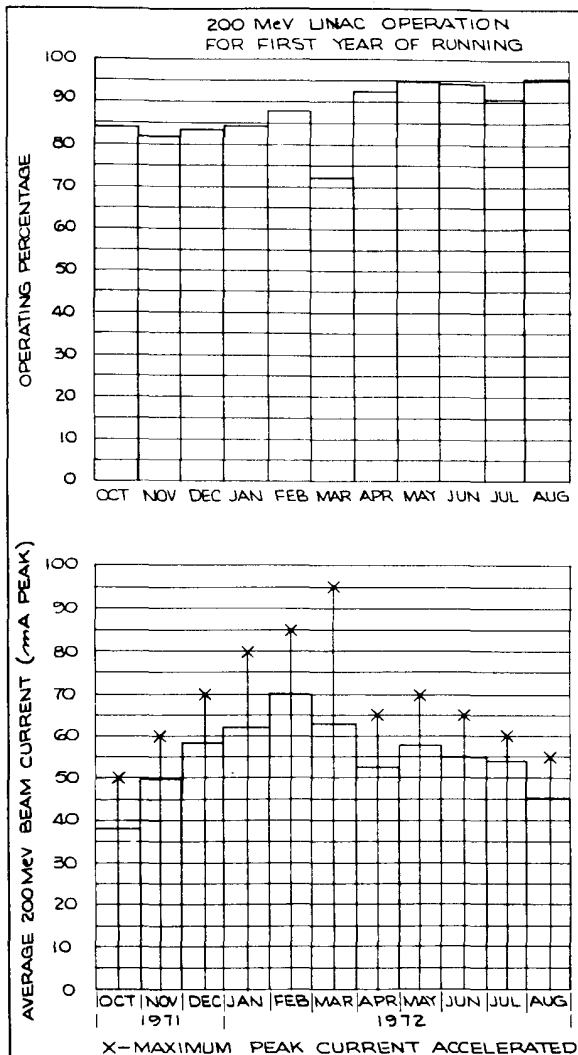

Fig. 2a. Block Diagram of RF System

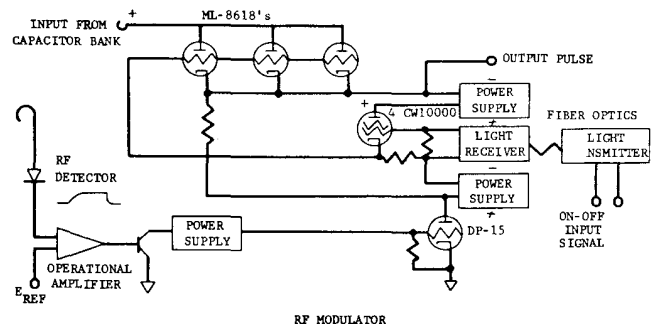

Fig. 2b. Schematic Diagram of the Modulator

Fig. 1. Average Monthly Operating Percentages

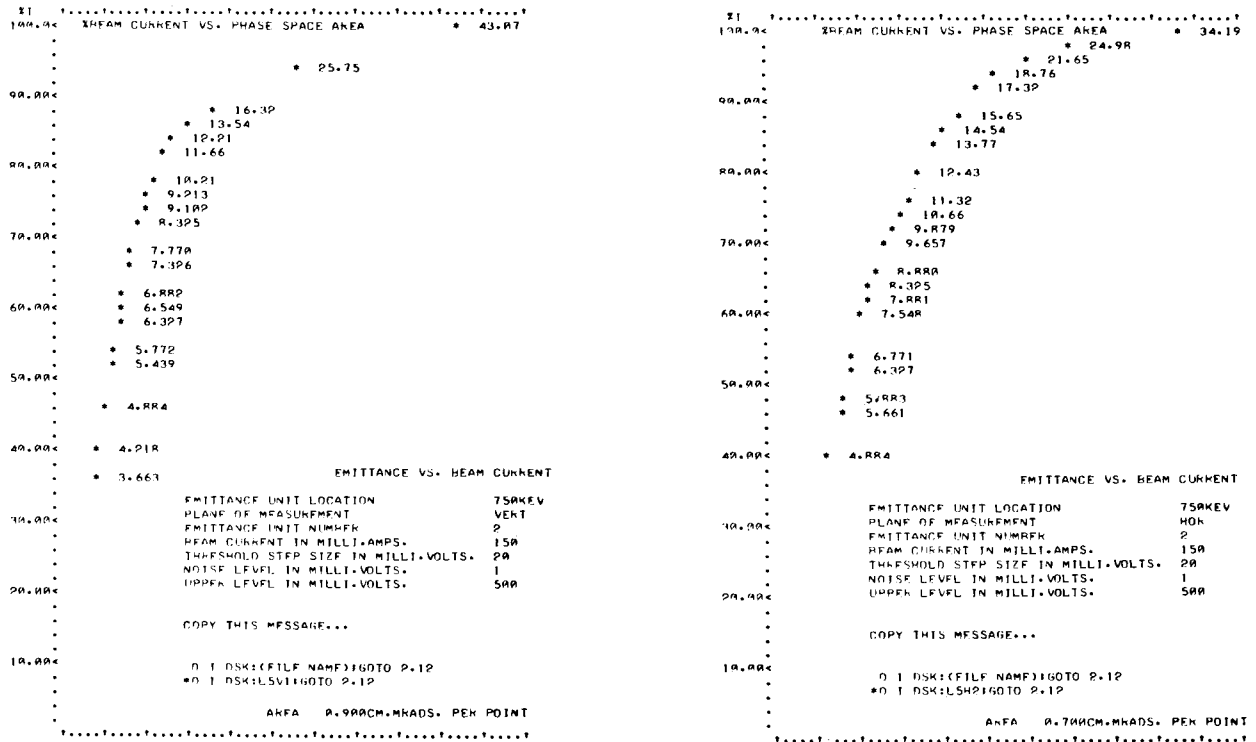

Fig. 3. 750 keV Emittance vs Percentage of Beam Current

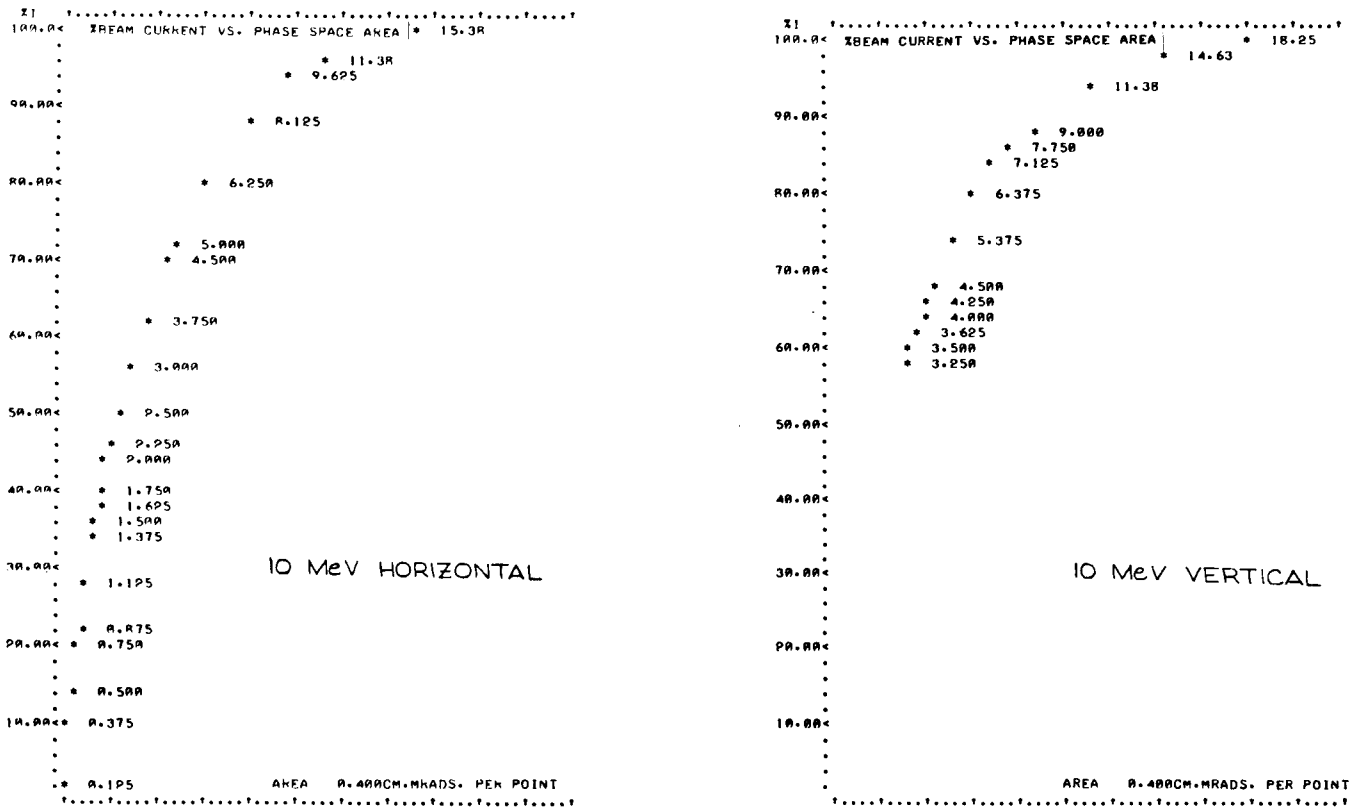

Fig. 4. 10 MeV Emittance vs Percentage of Beam Current

DISCUSSION

Featherstone, Central Engineering Co.: Have you data on tube life in the high power rf system comparable to that we heard this morning?

Batchelor: We have data. I wouldn't say it was comparable. We have had excellent lifetimes on the 4616's. We have lost one tube out of the 10 sockets in that area, and it had some 10,000 hours or more

of operation. With regard to the 7835's, we have 6 tubes that have failed in the two years of operation. All have failed in the 6 to 7 thousand hour lifetime period. All but one have failed in a similar mode. Cathode breakage appears to be the problem, and it may be a processing problem. The other failure is an interesting one, too, in that it clearly is a loss of emission, and rather rapid over the period of a week.