

MODERN ELECTRON LINACS AND NEW USER NEEDS

James E. Leiss
National Bureau of Standards
Washington, D. C. 20234

Introduction

The usual practice in a survey paper such as this is to give a summary of the many fine features and status of various electron linac projects under construction or recently completed throughout the world. I have chosen not to do this because most of these facilities have been very well described (and much better than I can do) in various previous linear accelerator and particle accelerator conferences, and especially because it appears to me that at this particular time in history we are at a point where the question of what the future holds is most important. This is true of proton linacs as well as electron linacs; however, I will confine my discussion to electron linacs. Thus, what I am attempting is a form of technological forecast of where present and future needs for electron linacs exist or will exist, and of various possibilities which exist to satisfy these needs. The discussion will be very general and lacking in detail, even perhaps oversimplified. I do not apologize for this. Most of the determining factors in what accelerator one builds are either quite simple concepts or else sufficiently complex that a detailed and specific study is required.

Why do I feel so strongly that we are at a turning point in the development of electron linac technology? There are three basic reasons for this as follows: (a) As is evident to all of us, there is a very substantial slowdown in the number and type of research facilities being built. New facilities must now, more than ever before, be very related to needs which represent a real change in what can be learned, measured or produced. Even then, the number of these facilities which can be supported will certainly be limited. (b) In terms of new performance capabilities the travelling wave electron linac has probably been exploited and developed to nearly the point of diminishing return. Travelling wave linacs, as exemplified by SLAC, (1) the new high duty cycle Saclay linac, (2) and the MIT 400 MeV high duty cycle (3) now under construction are really superb examples of travelling wave linac development. These accelerators have very good beam emittance. Some of them have energy spread and energy stability approaching 0.1 percent. The duty cycle has probably been pushed nearly as far as it is practical to consider for travelling wave linacs. By this I mean that while some further duty cycle improvement is possible, it will be sufficiently difficult and expensive that one should take a very hard look at other alternatives which would satisfy the needs of the accelerator users. (c) A number of new research and technology applications for electron accelerators are now becoming very exciting. Many of these applications might receive substantial benefit from linear accelerator developments which are somewhat different from the main emphasis of the past, but which appear to be technically and economically feasible.

In the remainder of this report we will attempt to develop the theme that the two extreme situations of high duty cycle accelerators on the one hand and high peak pulse current accelerators on the other hand are the areas of greatest current user interest, and to discuss accelerator developments which might satisfy these user needs.

What is a Linear Accelerator?

It is interesting that no adequate definition of a linear accelerator seems to have been developed which distinguishes the linear accelerator from other types of accelerators, especially potential drop machines of various types. Figure 1 is an attempt at such a definition. In this definition a linear accelerator, or a portion thereof, is represented by a black box into which a particle beam of a specific type enters with energy E and leaves with energy $E + \Delta E$. It is distinguished from all potential drop accelerators by the requirement that one be able to ground both the input and output beam pipes. This unique feature of the linear accelerator allows for energy expansion in essentially modular form as illustrated in Figure 2. Potential drop accelerators do not have this feature and thus rapidly run into serious economic and technical voltage hold-off difficulties as one attempts to construct higher energy potential drop accelerators.

One can make the above definition unique by requiring that the beam motion be essentially linear within the accelerator, which is certainly the normal interpretation of a linear accelerator. For purposes of this paper we relax this requirement at least to the extent of including various beam recirculation devices involving linear accelerators.

Electron Linac User Needs

As viewed by the user there are numerous properties of electron linear accelerators of interest. We attempt to summarize these properties in Table I. Some of these properties have different importance to different users. Thus, for example, the elementary particle physicist might possibly trade some beam current capability in order to achieve higher energy. His interest in higher energy is basically unbounded. This, however, is not the case for most users. Once the beam energy is above a necessary minimum they generally are no longer interested.

TABLE I
PROPERTIES OF ELECTRON LINACS OF INTEREST
TO USERS

Beam energy
Beam current, peak and average
Beam quality, emittance and energy spread
Duty cycle
Repetition rate
Short pulse current behavior
Size, complexity, reliability
Construction and operating costs

Similarly, the user of electron beams for their short pulse high current properties generally has nearly unbounded desires for peak pulse current but usually has very little interest in beam quality provided the beam can be delivered, properly conditioned, to his specified target volume.

It need hardly be mentioned that all users are greatly interested in reliability and construction and operating costs. For those interested in radiation processing and medical therapy this interest is often dominant.

With recognition of the above special situations we have attempted to examine various uses of electron linacs to identify common areas of need where accelerator technology developments might have large user benefits. These uses have been separated into three groups; those where existing technology seems adequate, those where increased duty cycle is important or essential, and those where increased pulsed beam current is important or essential.

Table II lists uses where technology appears adequate. Thus, while better beam emittance and energy spread is often desired for storage ring and most accelerator injectors, the technology to achieve these improvements is well developed. Likewise, while increased average beam current might open some new areas for radiation processing applications, the technology to achieve these improvements is available. The major improvements in this category of application are related to reliability and cost.

TABLE II

LINAC USES WHERE EXISTING TECHNOLOGY IS ADEQUATE

Injectors for storage rings or other accelerators
 Cancer therapy with electrons, photons and secondary beam particles
 Radiation processing
 Activation analysis
 Nuclear safeguards

Table III lists uses where increased accelerator duty cycle is important or essential. These are the areas of elementary particle and nuclear research where increasing emphasis is placed upon coincidence experiments. Such experiments will provide unique new information about nuclear and elementary particle structure, and are just barely possible at best with existing accelerators.

TABLE III

LINAC USES WHERE INCREASED DUTY CYCLE IS IMPORTANT OR ESSENTIAL

Elementary particle research
 Nuclear physics research
 Research with secondary particle beams, positrons, pions, etc.

The highest duty cycle available on currently operating electron linear accelerators is 2 percent on the high duty cycle linac at Saclay, (2) and a projected 5.8 percent for the MIT linac. (3) The electron prototype accelerator (EPA) (4) at Los Alamos Scientific Laboratory operated successfully

at 6 percent, and with improved waveguide cooling could have operated at 12 percent duty.

Table IV lists uses where increased pulse beam current is important or essential. In some of these applications linacs are already heavily used, but greater pulse beam current is desired. In other applications increased beam current is essential. For these latter applications pulsed potential drop accelerators are often employed; however, with higher beam currents electron linacs should find application in these areas.

TABLE IV

LINAC USES WHERE INCREASED PULSE BEAM CURRENT IS IMPORTANT OR ESSENTIAL

Production of pulsed neutron sources
 Transient chemistry studies
 Radiation effects studies and device simulation
 Transient radiography
 Beam plasma studies
 Collective accelerators
 Laser excitation
 Fusion research

Prospects for Increased Duty Cycle Accelerators

Various different schemes have been proposed whereby high duty cycle electron beams may be produced. The duty cycles possible from these various proposals would vary from roughly 10 percent to a full 100 percent. A summary of these various techniques is given in Table V.

TABLE V

TECHNIQUES FOR INCREASING DUTY CYCLE

Expansion of travelling wave linac technology
 Application of new waveguide structures
 Superconducting linacs
 Recirculation techniques
 Pulse stretcher storage rings
 Combinations of above techniques

The brute force method of duty cycle improvement by extension of the technology developed for the Saclay or MIT accelerators can certainly be accomplished up to duty cycles of about 10 percent. However, for higher duty cycle this approach would rapidly become more expensive and difficult. To this author some of the alternative approaches discussed below would seem to offer competitive alternatives.

The performance achieved by the EPA standing wave accelerator is quite impressive. This accelerator achieved a 6 percent duty cycle, higher than any operating travelling wave electron accelerator. Twelve percent duty cycle was available from the rf power source, but operation was limited by cooling difficulties which could be corrected.

The relative merits of travelling wave and standing wave structures can be compared by use of an effective shunt impedance (Z_{eff}) defined as

$$Z_{\text{eff}} \equiv \frac{[\text{Energy gain/Section length}]^2}{\text{Power loss/Section length}}$$

In terms of Z_{eff} the unloaded energy of a standing wave linac section is given by

$$E = \sqrt{Z_{\text{eff}} LP_0} = \sqrt{rLP_0}$$

and for a travelling wave linac section by

$$E = \sqrt{Z_{\text{eff}} LP_0} = \sqrt{rLP_0} \left\{ \begin{array}{l} \text{function of attenuation} \\ \text{and structure} \end{array} \right\}$$

where r is the shunt impedance, L the section length, and P_0 the input power. The effective shunt impedance for several different accelerator sections is compared in Table VI. To allow comparison of Z_{eff} between accelerators operating at different frequencies, the values have been normalized to 2856 Mhz, assuming a square root of frequency dependence of Z_{eff} . The factor of two higher values of Z_{eff} for the standing wave structure, and consequent factor of two less power required for a given energy gain in a given length accelerator section is clear. A proposed application of these advantages to a high duty cycle accelerator for photo-nuclear physics studies is discussed below.

Proposals have been made by several groups (8-10) to increase the duty cycle of linear accelerators by recirculating the electron beam through the accelerator two or more times. For a beam which recirculates N times through the accelerator, the effective shunt impedance of the accelerator section is increased by N^2 , with corresponding reduction by N^2 in input power requirement if the same final energy is desired as with no recirculation. (Recirculation also, of course, allows the possibility of increased energy as is planned in the RLA project at SLAC.(10))

Figures 3 and 4 illustrate schematically two variations of proposed recirculation linacs which would have high duty cycle. The first of these, the race track microtron, is under study at the University of Illinois (9) using a small CW superconducting linac as the accelerating section. While the voltage gradient achieved in the accelerator section is less than desired, this group has successfully achieved one recirculation of the beam thus far. (11)

The accelerator depicted in Figure 4 has been proposed by the Ames Laboratory (12-13) and takes advantage of the high Z_{eff} of the side-coupled standing wave structure. The structure is identical to the EPA accelerator at Los Alamos (4) with the exception of a 40 percent increase in length. Required input power is reduced by recirculating the beam back through the cavity in the opposite direction (possible with a standing wave structure). This accelerator would require one 500 KW peak power klystron (at low beam current). If available as a CW tube the accelerator would have 100 percent duty cycle. This accelerator would be a very powerful tool for low energy photo-nuclear physics studies.

TABLE VI
EFFECTIVE SHUNT IMPEDANCE (Z_{eff}) FOR SEVERAL ACCELERATORS

Accelerator	Section length (Meters)	Operating Frequency (Mhz)	Z_{eff} (Meg ohm/meter)	Z_{eff} (Scaled to 2856 Mhz)
Saclay (2)	6.0	2998	44.8	43.7
MIT (3) (short section)	3.67	2856	41.6	41.6
MIT (3)	7.35	2856	40.7	40.7
SLAC (1)	12.2	2856	32.7	32.7
NBS (5)	2.5	1300	21.6	32.0
EPA(LASL) (4)	18.0	805	46.0	86.9

The extreme example of improvement in Z_{eff} is given by the superconducting linac, in which case Z_{eff} is very large and essentially all the rf input power required is for beam loading. Since the status of programs to develop superconducting accelerators is summarized in other papers of this conference, (6-7) it will not be discussed further here.

Pulse stretcher storage rings to extend the duty cycle of existing low duty cycle linacs have been proposed by several groups. (14-15) The manner in which this might be accomplished for the University of Saskatchewan linac (14) is illustrated in Figure 5, which indicates the advantage of being able to use existing buildings, beam transport, and experimental facilities.

In these devices the stretcher ring would be filled by the low duty cycle linac in short bursts and the beam spilled slowly between bursts by extraction at the radial one-third resonance. While such stretcher rings appear technically feasible they become rather elaborate ring structures and will have many of the problems normally encountered in electron storage rings. They have the added difficulty of slow beam extraction. They appear to be very attractive for high duty cycle accelerators above about 100 MeV. Below 100 MeV accelerators such as proposed in Figure 4 may be competitive.

Prospects for Very High Peak Current Linear Accelerators

Many of the applications of high pulsed beam current listed in Table IV require beam current much higher than has been achieved with travelling wave linacs. In some of these applications pulsed potential drop accelerators are used, but these accelerators become very expensive and complex for energies above 2-3 MeV and pulse lengths greater than 0.1 microseconds. They also usually have much poorer beam quality than desired for many applications.

For these applications the induction linear accelerator offers promise. Considerable development of the induction linear accelerator concept has occurred in the last few years which results in substantial reduction in cost and complexity and improvements in performance. An indication of these developments is given in Table VII where the properties of several induction linear accelerators either existing or under study are listed. For comparison the high peak current travelling wave accelerator ORELA (16) is also indicated. The much higher pulse repetition rate capability but lower peak beam current of the travelling wave accelerator is evident.

time varying eddy currents in the toroid. Because the eddy currents vary with time, modulator pulse compensation is required to achieve constant accelerating voltage during the pulse. Since the pulse length-energy gain product from a toroid is proportional to the total magnetic flux density change, ΔB , available, the toroids are reset to their negative remanence, B_r , between pulses. This is accomplished by a reset pulse between beam bursts. Figure 7 is a typical hysteresis curve for a large magnetic toroid illustrating these points.

The ASTRON (17) accelerator is constructed as indicated in Figure 6 using 50-50 Ni-Fe foil. The major problems of this approach are the expense of large numbers of Ni-Fe toroids and the large number of modulators required. At NBS we have demonstrated that low cost, low carbon steel foil can be used for toroids as illustrated in Figure 7. The increase in core reset pulse current required is more than offset by the lower cost and availability of the low carbon steel foil. The increase in eddy current due to lower resistivity is eliminated by using thinner foil.

The number of modulators required for induction linacs can be greatly reduced by operating the magnetic cores in a voltage step-up configuration. Two arrangements to achieve this are indicated in Figures 8 and 9. In Figure 8 several magnetic cores are stacked axially and excited in parallel from a common modulator, with a single secondary path around the several cores. This approach is utilized in the 30 MeV accelerator now being built at Dubna. (19) In Figure 9 several magnetic cores are stacked radially and excited in parallel from a common modulator with a single secondary path around the several cores. This approach requires considerably more magnetic material and more modulator drive power. It is acceptable if the low carbon steel indicated in

TABLE VII
COMPARISON OF SOME HIGH CURRENT ACCELERATORS

<u>Facility</u>	<u>Energy (MeV)</u>	<u>Peak Current (Amperes)</u>	<u>Pulse Length (μ sec)</u>	<u>Repetition Rate (pps)</u>
ORELA (16)	140	16	0.01	1000
ASTRON (17)	5	800	0.3	5
ERA Injector, LBL (18)	4	900	0.025	1
Dubna (19)	30	250	0.5	50
NBS (20)	100	2000	2.0	1

The basic principle of the induction linear accelerator is indicated in Figure 6. Magnetic toroids made of thin magnetic foil are excited by a low impedance pulse modulator to induce a large magnetic flux swing within the iron toroids. By induction a secondary winding around the toroid will have a voltage equal to the modulator voltage across the gap in the secondary winding. Since the field in the secondary gap is an induction field, one can ground the beam pipe between gaps. The current from the modulator must be sufficient to drive the beam current and to supply substantial

Figure 7 is used for the magnetic cores. The great advantage to this approach is the considerable reduction in accelerator length achieved, which is important for both cost and beam transport considerations. This approach has been utilized in an accelerator design study at NBS.(20) Figure 10 shows such an accelerator core assembly which has been operated at 200 keV and 2 microsecond pulse length. The iron cores are completely enclosed in copper cans and driven by large copper sheets to minimize stray inductance. Two such cores together with pulse modulators and reset

circuits are placed in a common oil tank. The arrangement of these modules together with focusing elements to form an accelerator is shown in Figure 11.

An additional serious difficulty with most induction linear accelerators is the rapidly time varying nature of the magnetic core eddy currents, which causes distortion of the input drive pulse. On the ASTRON accelerator this distortion is compensated by an adjustable mismatch in the drive lines between the modulators and the accelerator. On the Dubna accelerator the modulator pulse line is tapered to correct for the varying load. Both of these approaches to pulse compensation suffer from the difficulty that the accelerating voltage pulse shape is quite sensitive to beam current level. Pulse shape readjustments are required if the beam current is changed. In the NBS program this difficulty has been almost completely removed by adding passive pulse shaping networks at the accelerating cores so that the sum of magnetic core load plus pulse compensator network appears resistive. The resulting accelerator pulsing system is indicated schematically in Figure 12.

The very high beam currents of induction accelerators pose unique beam dynamics problems. In addition to the usual beam dynamics considerations, space charge forces, space charge neutralization due to ion formation during the pulse, resistive wall forces, and rf beam blow-up must be considered. Beam dynamics programs which include these effects have been developed at NBS. (21) These programs have been demonstrated to predict the performance of the ASTRON accelerator reasonably well, and predict that an accelerator such as in Figure 11 will have very good beam transmission at the 2000 ampere beam current level. For long accelerators the dominant problem is rf beam blow-up due to resonances in the low Q accelerating gaps. The starting signal for cavity excitation will probably be shock excitation during beam turn-on. All possible means to suppress beam blow-up must be employed including Q reduction techniques, stagger tuning of resonances over a substantial frequency range, and greater solenoid field than would otherwise be required. With these measures, however, induction accelerators of 100 MeV and 2000 amperes beam current appear feasible.

Conclusion

In this report we have attempted to examine the desires of electron linear accelerator users and the status of linac technology in an attempt to identify areas where substantial new electron linac developments are desired and possible. The two major areas of need and capability identified are those of high duty cycle accelerators and those of high pulse beam current accelerators. Examples of developments in each of these areas are presented which indicate that accelerators satisfying users' needs can be built.

It is recognized that any attempt such as this to do technology forecasting is subject to differing opinions, and can be overturned by new developments. In this connection the remarks of John Blewett (22) at the 1966 Linear Accelerator

Conference are most appropriate.

"In conclusion, it should be said that every year has brought new ideas and surprises to the field of linac development; this is what has made it worthwhile to hold five linac conferences in a period of five years. I am sure that many new approaches of which I have not heard will be announced at this conference. Consequently it is with considerable anticipation that I yield the stage to the people who are really making the advances in the linac art."

References

1. R. B. Neal, ed., The Stanford Two-Mile Accelerator (W. A. Benjamin, Inc., New York, 1968).
2. H. Leboutet, G. Azam, F. Netter, and C. Tzara, First operation of the high duty cycle Saclay electron linac (A.L.S.), IEEE Trans. Nucl. Sci. NS-16, No. 3, 299 (1969).
3. W. Bertozzi, J. Haimson, C.P. Sargent, and W. Turchinets, The MIT high duty, high intensity 400 MeV linear electron accelerator, IEEE Trans. Nucl. Sci. NS-14, No. 3, 191 (1967).
4. E.A. Knapp, Resonantly coupled standing wave accelerator structures for electron and proton linac applications, IEEE Trans. Nucl. Sci. NS-16, No. 3, 329 (1969).
5. J.E. Leiss, The NBS linac, Proc. of 1966 Linear Accelerator Conference, LA-3609, 20 (1966).
6. P.B. Wilson, Current status of superconducting accelerator technology, (this conference).
7. Bernd Matthias, Future possibilities for superconducting linacs, (this conference).
8. H.R. Froelich and Eric Brannan, Four sector racetrack microtrons, IEEE Trans. Nucl. Sci. NS-14, No. 3, 756 (1967).
9. D.C. Sutton, A.O. Hanson, D. Jamnik, C.S. Robinson and P. Axel, Design of a 600 MeV superconducting microtron, IEEE Trans. Nucl. Sci. NS-16, No. 3, 985 (1969).
10. W.B. Herrmannsfeldt, et al, Recirculation of the SLAC beam, 8th Int. Conf. on High-Energy Accelerators, CERN (1971), p. 563.
11. A.O. Hanson, private communication.
12. J.E.E. Baglin, Experimental possibilities for a 50 MeV electron linac with long duty factor, IEEE Trans. Nucl. Sci. NS-18, No. 3, 572 (1971).
13. The accelerator indicated in Figure 4 is a CW variation of the accelerator proposed in reference 12, J.E.E. Baglin, private communication.

14. R. Servranckx and J.L. Laclare, Concept and general design of an electron pulse stretcher, IEEE Trans. Nucl. Sci. NS-18, No. 3, 204 (1971).
15. C.H. Westcott and J.L. Laclare, Some design features of an electron storage ring used as a pulse stretcher, 8th Int. Conf. on High Energy Accelerators, CERN (1971), p. 159.
16. C.N. Pering and T.A. Lewis, Performance of 140 MeV high current short pulse linac at ORNL, IEEE Trans. Nucl. Sci. NS-16, No. 3, 316 (1969).
17. J.W. Beal, N.C. Christofilos and R.E. Hester, The ASTRON linear accelerator, IEEE Trans. Nucl. Sci. NS-16, No. 3, 294 (1969).
18. D. Keefe, Status report on ERA, Berkeley, 8th Int. Conf. on High Energy Accelerators, CERN (1971), p. 397.
19. A.N. Anatsky, *et al*, Design of 30-MeV linear induction electron accelerator - injector for NEP-2 pulsed reactor, IEEE Trans. on Nucl. Sci. NS-18, No. 3, 625 (1971).
20. J.E. Leiss, private communication. Considerable assistance in hardware development for this program has been provided by E.G.G., Santa Barbara, California.
21. S. Penner, private communication. Considerable assistance in microwave measurements and in rf beam blow-up calculations have been provided by Haimson Research Corp., Cambridge, Mass.
22. J.P. Blewett, Linacs of the future, 1966 Linear Accelerator Conference, LA-3609, 1 (1966).

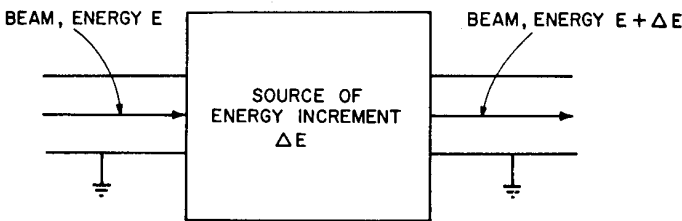

Fig. 1. Illustration of a definition of a linear accelerator from a potential drop accelerator.

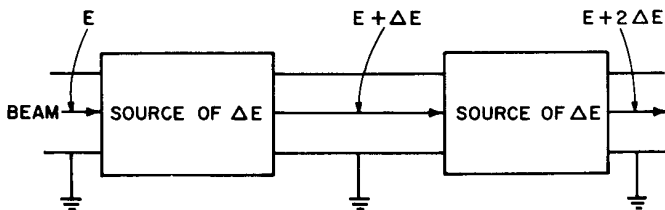

Fig. 2. Illustration of energy expandability of linear accelerators.

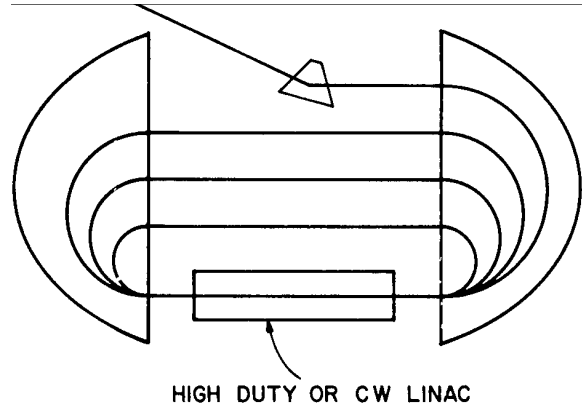

Fig. 3. Schematic illustration of racetrack microtron.

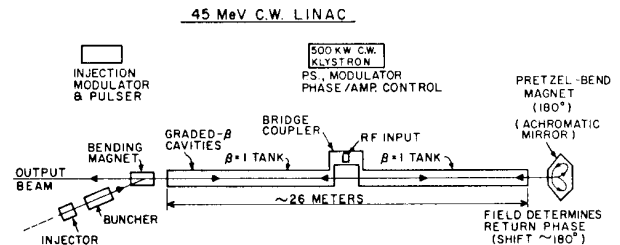

Fig. 4. Schematic illustration of 45 MeV CW linac using side-coupled standing wave structure and one recirculation of the beam.

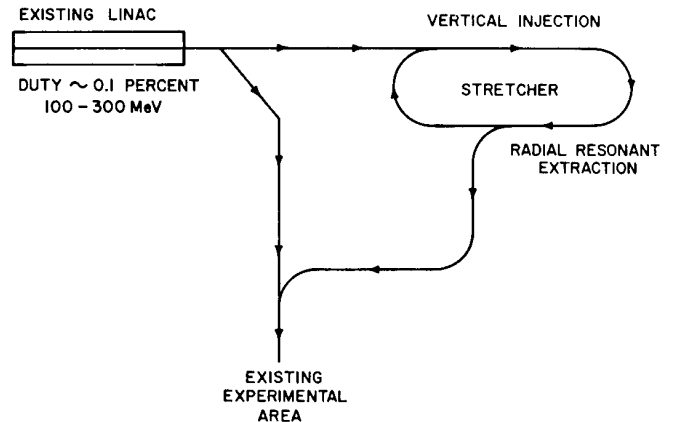

Fig. 5. Proposed layout of University of Saskatchewan pulse stretcher storage ring. (Expected duty cycle 80%.)

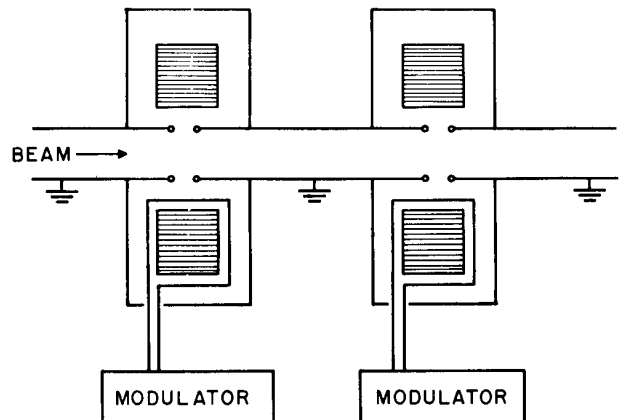

Fig. 6. Illustration of the basic principle of linear induction accelerator.

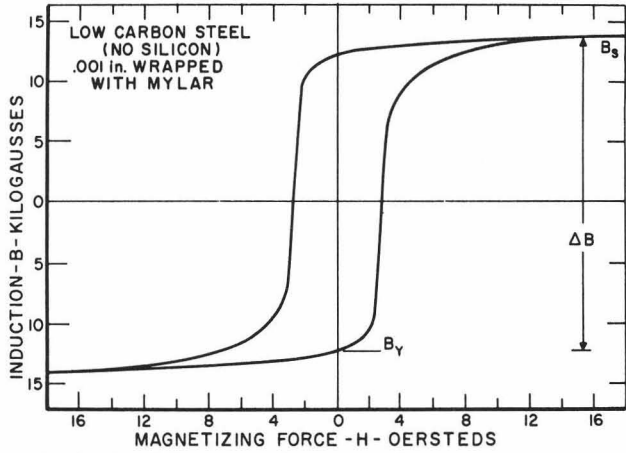

Fig. 7. Typical hysteresis curve for a large magnetic toroid. The total flux swing ΔB is available during pulsing.

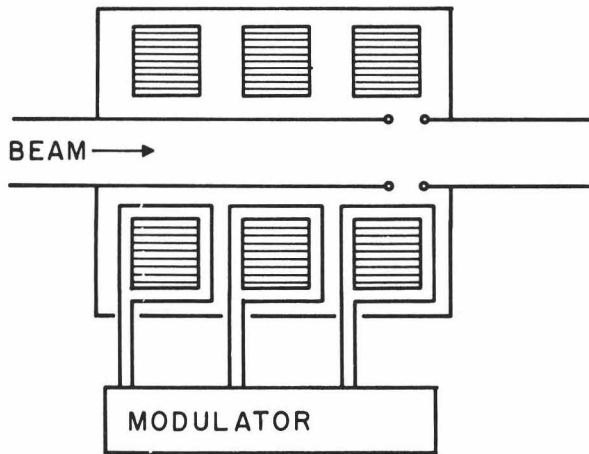

Fig. 8. Longitudinal stacking induction accelerator cores to achieve voltage stepup.

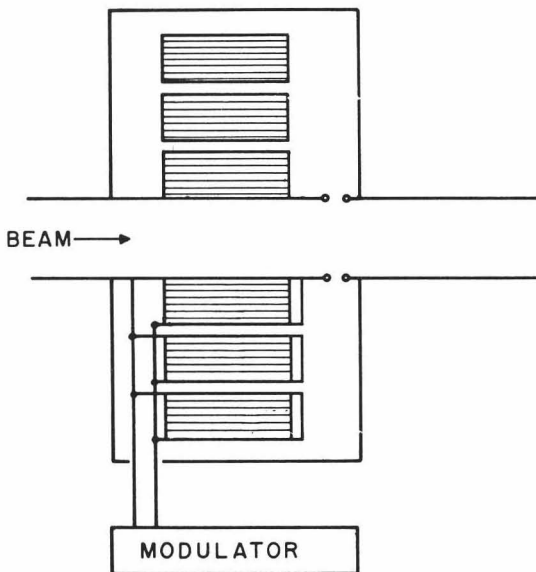

Fig. 9. Radial stacking of induction accelerator cores to achieve voltage stepup.

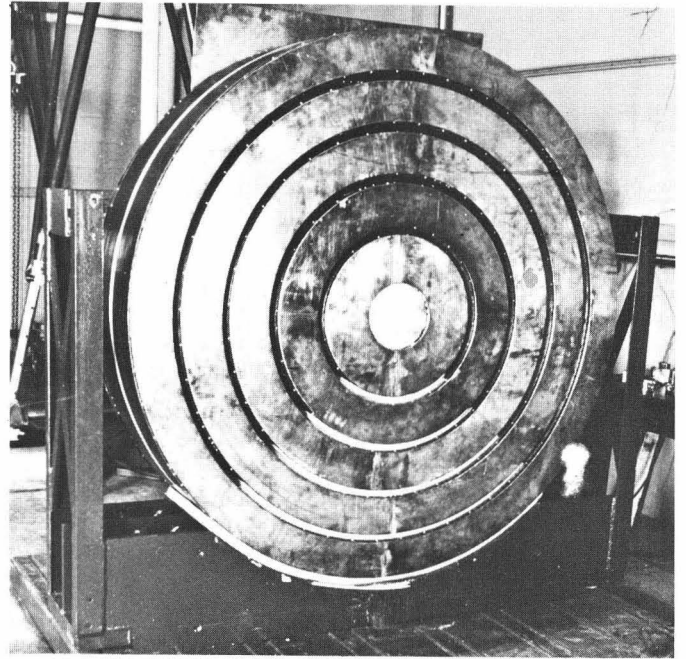

Fig. 10. Photograph of radially stacked induction core assembly with 5-1 voltage stepup. This core will operate with 200 keV acceleration for 2 μ sec pulses. With salt water loads it has been demonstrated to operate properly at 8000A of load current limited by the pulse modulator.

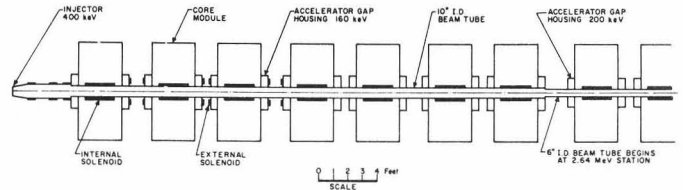

Fig. 11. Layout of accelerator cores as in Fig. 10 with injector and focusing elements to form an accelerator. For extension to higher energy the geometry is repetitive past the 2.64 MeV point.

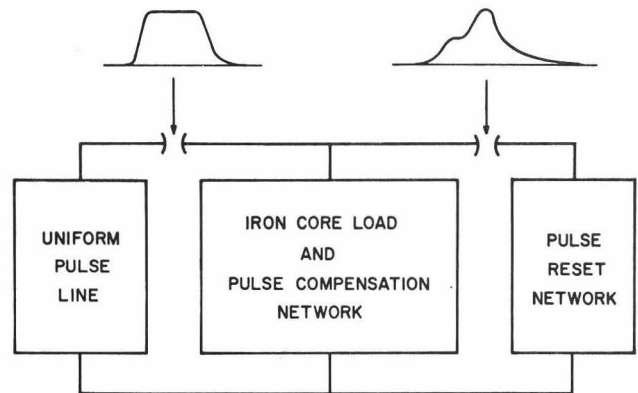

Fig. 12. Schematic layout of pulsing circuits to drive the accelerator core assembly shown in Fig. 11. By use of a uniform pulse line and by locating pulse compensation networks at the accelerator cores considerable independence of accelerating voltage pulse shape with changes in beam current is achieved. Typical accelerating pulse and reset pulse waveforms are indicated.

DISCUSSION

G. Kolstad, AEC: Can you make any comment on the possibility of beam pinching as a method for transporting heavy ions?

Leiss: Let me start out with electrons. For electrons you certainly can transport pinched beams provided you use solenoids and not quadrupoles. It is absolute death if you use quadrupole focusing systems. For negative heavy ions, I think it is quite possible to do this; but for positive heavy ions this becomes a much more difficult affair. I really don't know what to say for positive heavy ions.

L. Smith, Berkeley: I believe the heavy ion question is rather different. The intensities are sufficiently low that normal beam transport systems are quite adequate for that purpose. In fact, if you are not in a completely stripped charge state, you can get into all kinds of trouble if you try to use a plasma type focusing system.

Leiss: I would agree with that.

A. Citron, Karlsruhe: I would like to argue with one of the entries in the early tables. You said that for cancer therapy, present linacs were adequate. My feeling is that they could well do with a stepup of a factor of 100 or so in average current. I am referring to the pions produced from electron linacs, the dose rates that one can obtain are marginal. One can, by adequate focusing and long exposure, just about get the required doses; but if one were to have an average current about two orders of magnitude higher, he could probably get a much more efficient kind of treatment, say in terms of throughput of patients.

Leiss: I would agree with you to some extent, but I would be very surprised if the two orders of magnitude is, in fact, a realistic number. You would not know what to do with the beam.

I should qualify this; I tried to qualify my remarks in the beginning of my talk. I believe we know how--and have really demonstrated that we know how--to build accelerators with the higher beam powers that I think will be sensible for this. You will really need more beam power than you presently have. But, an average current of 1 mA at 500 MeV is 500 kW of beam power. I think we know completely how to build such machines, and I don't really think there would be any specific surprises involved in building it. I was trying to indicate areas where we have demonstrated where we know how. Now, one might argue whether we really do know how to build a 500 MeV, 1 mA accelerator; that is a different matter. Would you agree with that or not?

Citron: Yes, my statement would be that for this particular application, 1 mA is on the lower side of what one would need. Now, I agree that the higher average current is rather difficult to envisage, but I think that from the consumer's point of view, if one looks at how many pions he would like to get per unit time stopped in a volume, then one would certainly wish to have a higher electron current.

Leiss: What would you say, 100 mA?

Citron: Yes.

Leiss: Average current?

Citron: Yes.

Leiss: Man, what a beam!