

ION SOURCES FOR PROTON LINACS*

Th. Sluyters
Brookhaven National Laboratory
Upton, New York

This is a review of the present performance of the ion sources in the world's largest proton linacs installed in the following laboratories: National Accelerator Laboratory (Batavia, USA), Argonne National Laboratory (Chicago, USA), Rutherford High Energy Laboratory (Chilton, England), CERN (Geneva, Switzerland), Los Alamos Scientific Laboratory (Los Alamos, USA), Centre d'Etudes Nucleaire (Saclay, France), Institute for High Energy Physics (Serpuukhov, USSR), Brookhaven National Laboratory (Upton, USA), and Institute of High Energy Physics (Tsukuba, Japan).

Introduction

After several years of extensive development most proton sources for high energy accelerators are now operating with very reliable records. They operate in a pulsed mode for several consecutive months at beam currents varying from 50 to 500 mA. Their emittance is, in most laboratories, significantly smaller than the acceptance of the machines they inject into. Such a performance does not stimulate source development. But brighter beams are already requested, not solely for another generation of accelerators (such as storage rings), but also for improving trapping procedures and for reducing radiation damage. It is then quite natural to look first into possible improvements of the beam quality from the source.

The ion source for these accelerators is the duoplasmatron with plasma expansion cup. Its development started in the beginning of the sixties with the construction of high gradient accelerator tubes. The duoplasmatron itself was chosen for its reliability, its wide range of operational beam currents and good emittance or brightness properties. But the choice is tradition of the laboratory and preference of the responsible engineer as well. There is no doubt that other sources can obtain similar or better results; an example is the PIG source for the Brookhaven Cosmotron¹, as developed over many years by C.M. Turner. Its reliability is shown by an uninterrupted service of 1500 to 3000 hours. The brightness at 78 mA was significantly larger than any reported duoplasmatron result, namely, 3×10^{13} amps/m²rad², though their measuring technique of observing the divergence of the shadow instead of the divergence of thin beam segments has not been experimentally verified. The explanation of this exceptional performance might be that the extraction of protons takes place directly in the discharge region of the source instead of extraction of protons after plasma expansion in duoplasmatrons with expansion cups.² In addition this Penning source has reached currents as large as 500 mA on the test stand. Figure 1 shows a sketch of the source. Notice the position of the protruding rear cathode, which increased the plasma density. A possibility to avoid the delicate touch

of the aluminum rear cathode might be found in the development of a thermionic cathode. The thin tantalum front cathode withstood the heat and permitted to bring the extractor voltage as close as possible to the plasma where the ions were generated. The platinum tipped probe permitted an extraction voltage of 30 kV.

A second example is the more complicated rf source as developed by Uno Tallgren of CERN.³ Figure 2 shows this rf proton source developed around 1966. Brightness figures of 3.5×10^{11} A/m²rad² were obtained for 90 mA, which is an order of magnitude higher than the sources presently used in the operational machines. This brightness might be explained in a similar way as the performance of the above mentioned PIG source, namely direct, high voltage extraction from the discharge area.

A Comparison of Parameters

Table I shows the parameters of the individual duoplasmatrons.

The Cathodes

The reliability of sources is demonstrated by the time span of uninterrupted service. For pulsed duoplasmatrons this is mainly determined by the lifetime of the cathode. All laboratories except Serpuukhov employ the oxide cathode of its low power consumption and for its long lifetime. If properly constructed and with proper vacuum care, this lifetime may exceed 6000 hours (Saclay). The hot filament has a lifetime of only 1000 hours, but it is easier to make and not subject to poisoning. In each source the location of the filament is assumed to be optimized for minimum gas consumption. There is not a clear indication that metal seals are required for improved operation and (or) beam quality.

The Discharge Parameters

The short snout channel in the Batavia duoplasmatron (see also Fig. 4) is used to reduce beam losses in the channel. Its shape and long snout anode distance have been chosen to obtain a specific magnetic field configuration.⁴

The gas consumption rate in the CERN source is exceptionally high, which cannot be well understood. The large anode aperture of 1.5 mm in the Serpuukhov source is required in order to fill the large expansion cup with plasma. To avoid high pressure in the accelerating column, the hydrogen flow is regulated by a pulsed valve with a lifetime of 10⁶ pulses. Therefore, the gas consumption is only one to three cm³ atm/min.

The high arc current of 75 amperes at CERN supports the high plasma density in the relatively small expansion cup.

*Work performed under the auspices of the U.S. Atomic Energy Commission.

The high magnetic field of 7 kG at Saclay is required to guide plasma through the long narrow expansion cup (see Fig. 9).

The Expansion and Extraction Geometries and Beam Qualities

These are the critical regions for accelerator sources, because the form of the plasma boundary from which the ions are extracted is governed by the geometry of the plasma cup, by the geometry and voltage of the extractor electrode and by the plasma density distribution. An extensive review of the properties of ion extraction from ion sources is given by Septier.¹⁵

The expansion and extraction geometries are shown together in Fig. 3, drawn in the same

scale. This picture shows clearly the large variety of cup volumes from less than 1 cm³ in Los Alamos up to about 1000 cm³ in Serpukhov.

The goal of each up end extractor designer is to guide the plasma in a controlled fashion to the exit of the expansion cup. The brightness figures suggest that the laboratories at CERN, Los Alamos and Saclay are the most successful. The large plasma cup at Serpukhov is an extreme case of plasma dilution required to focus a large variety of beams properly through the accelerating tube. However, a large dilution before extraction deteriorates the beam quality.

In Table II we have compared the exit areas with the extracted currents, the current densities, space charge limited currents and brightnesses.

TABLE II

Laboratory	Exit Area (cm ²)	Intensity (A)	Current Density (A/cm ²)	Space Charge Limited Current (A/cm ²)	Brightness (10 ¹⁰) (A/m ² rad ²)
Batavia	5.72	0.250	0.043	0.055	0.78
Chicago	1.32	0.150	0.113	-	0.83
Geneva	3.14	0.500	0.159	0.165	3.6
Los Alamos	1.54	0.048	0.031	0.039	1.53
Chilton	3.14	0.200	0.063	0.204	0.81
Saclay	0.78	0.048	0.061	0.091	2.4
Serpukhov	69	0.300	0.0043	0.0356	0.6
Upton	3.8	0.250	0.065	0.265	0.34

The current density at Serpukhov assuming a uniform plasma distribution is significantly smaller compared with other expansion cups. It might be possible that for lower densities the exit area of this source is not completely filled up with plasma, but concentrated in a smaller area. The plasma is then held together by the electron beam ejected from the source.

The table shows also that the best brightness figures are obtained in Geneva, Saclay and Los Alamos, where the extracted current densities are close to the space charge limited current. As I will discuss in the next chapter this performance may be explained by different methods of controlling plasma expansion. For instance in the medium intensity sources at Los Alamos and Saclay this control is achieved by biasing the cup walls, while for the expansion of the dense plasma jet at CERN the plasma is guided by an auxiliary magnet, located close to the cup entrance.

The Individual Plasma Expansion Cups

Batavia⁴

The design of this plasma cup is still in a state of evolution (see Fig. 4). At first a parallel beam of 35 mA was obtained with a plasma cup being only 1 cm in diameter. To obtain a higher beam current without developing a new larger expansion cup the extractor was electrically connected to the cup and extraction took place using the next

available electrode. Beam currents up to 260 mA were accelerated, but not in accordance to the ideal Pierce geometry. In an attempt to provide a large plasma surface area in a Pierce geometry the plasma cup was scaled linearly in all dimensions to the present diameter of 2.8 cm. Only by increasing the length to 7.5 cm a parallel beam of 150 mA was provided. A further plasma expansion using the above mentioned technique of expanding the plasma up to the extractor, increased the beam output to the present operating value of 250 mA. So far the insulated cup walls in this design are used as a beam chopper.

Other important developments in this laboratory are the computer controlled emittance probe and data acquisition system (see Fig. 4a). The emittance, the density distribution or beam profiles are acquired and processed within a few seconds. The merits of this monitoring technique are obvious.

Chilton⁵

A miniature duoplasmatron (see Fig. 5 and Fig. 5a) with an overall diameter of 8 cm has been built in this laboratory by Wroe et al. The small source-dimensions were achieved by an effective layout of the magnet and a cooling circuit spiraling down under the coil and returning on the outside of the coil. The vacuum seals are made of indium wire. The extraction electrode is extended into the accelerating column in the form of a

cylinder for a proper beam match in the same way as the extractor-focusing electrode in the previously discussed PIG source.

Geneva⁶

While other laboratories aimed for lower beam currents and parallel beams, the CERN source was constructed with the intention to obtain half an ampere or more in a single gap accelerating structure (see Fig. 6). This has been achieved by:

- a) a high discharge current
- b) locating the peak of the source magnetic field very close to the first aperture by proper shaping of the anode entrances
- c) an additional shielded coil, which magnetic field falls off rapidly towards the plasma boundary.

The 45° cones inside and outside the cup were installed following the idea of Rose⁷ in order to shape the plasma boundaries. These cones are not optimized; overlapping emittances occur, indicating the existence of a protruding plasma boundary.

The extractor electrode has a 90% transparent molybdenum grid for the obvious reason to avoid the effects of fringing fields.

Los Alamos⁸

The carefully designed Los Alamos source has reached a high degree of perfection in the control of the plasma boundary at the exit of the plasma cup (see Fig. 7). The cup exit is well shielded from magnetic fringing fields. An almost "exact" parallel beam, without significant distorted edge effects has been obtained by biasing the downstream front-end of the anode electrode, which forms the first electrode of the Pierce accelerating column. The theory behind this insulated part of the cup is that the plasma tends to bulge out into its own potential range (see Fig. 7A). Therefore, ideal Pierce extraction assumes plasma and electrode on the same negative potential (see Fig. 7B), which is assumed to be about -50 V. In practice a voltage of -200 V is applied. The disappearance of the edge effects was verified by the pepper pot emittance method and by tracing back the trajectories to the expansion cup exit.⁸ This theory was later confirmed by the Saclay group.⁹

The duty cycle of the Los Alamos source is 6% (120 pulses of 500 μ s). The initial burnout problem of the anode aperture has been solved by copper cooling.

Saclay^{9,10}

The long and narrow expansion chamber with biased inside and outside walls is the result of many years of development work (see Fig. 8). Like the Los Alamos source the beam behaves according to the Pierce theory obtaining an almost flat density distribution when proper biasing of the walls is applied. The bias on the inner wall reduces the beam losses and affects, like the outer wall, the density distribution at the exit of the expansion cup. The long length of the cup was chosen to avoid

magnetic field aberration at the plasma boundary.

Serpukhov¹¹

A very long 15 cm expansion cup, 9.4 cm in diameter, seems to be required to transport a wide range of beam currents properly through the large diameter accelerating tube (see Fig. 9). As at CERN the peak of the magnetic field is very close to the first plasma aperture of ϕ 1.5 mm. The second larger plasma aperture forms the second pole of the magnetic field loop. The rounded edges of this pole avoid magnetic saturation. The extractor has a grid made of tungsten.

Though much higher beams have been obtained with this source, its regular operation current is 300 mA.

Upton¹²

The initial plasma expansion cup with dimensions of 12 x 9 mm as described during the first International Ion Source Conference in Saclay has been replaced by R. Lankshear for a considerable larger chamber 22 x 31 mm of the configuration shown in Fig. 10. Some of the magnetic shielding has been removed to allow penetration of the field into the larger plasma cup. This was required to achieve the 250 mA beam current. A 150 kV source facility with an on-line PDP-8 computer for data acquisition is under construction.

Tsukuba¹³

A nozzle type of plasma expansion cup is under investigation at the Institute of High Energy Physics at Tsukuba, Japan, according to a design as suggested by Kovarik et al.¹⁴

The choice of such a shape is based on the theory that in high pressure duoplasmatrons a significant part of protons is formed by the primary electron beam around the vicinity of the anode aperture downstream the potential hill of the discharge region. The transport of these protons towards the extraction boundary is influenced by diffusion laws. One can therefore expect an improved plasma density distribution and reduced losses on the walls by shaping the cup contours as a supersonic nozzle. Its dimensions are determined by the boundary conditions at the entrance (throat), the exit area and the cup length. Figure 11 shows the initial experimental nozzle chamber. It has the possibility to interchange and bias wall sections. Preliminary results are encouraging. Hundreds of milliamperes have already been extracted, e.g., 300 mA within a normalized emittance of 0.2 cm x mrad. These results are published in the Proceedings by Fukumoto et al.

Conclusions

Plasma expansion from duoplasmatrons to obtain ion currents up to 100 mA and ion densities up to 60 mA/cm² are well under control. These expansion cups are not larger in diameter than 1.5 cm and insulated walls provide some control on the density distribution (Los Alamos, Saclay). For higher intensities and larger expansion cups, the transport of plasma is more complex. Insulated

walls do not have a significant effect (Batavia). Miniature shielded solenoid(s) located close to the anode aperture appear to be effective for high density plasma transport (Geneva). Nozzle shaped expansion cups might improve the plasma transport (Tsukuba). Optimum beam optical results are often obtained when extraction takes place close to the space charge limited current (Geneva, Los Alamos, Saclay).

In the past decade we have improved the beam brightness from about 10^9 A/m² × rad² to around 10^{10} A/m² × rad². The development of a PIG source as a high intensity proton source is a promising possibility to increase the brightness by another order of magnitude, which will be difficult to achieve with present plasma expansion techniques from duoplasmatrons.

References

1. G.W. Bennett, C.M. Turner, IEEE Trans. Nucl. Sci. NS-14, 3, 65 (1967).
2. Th. Sluyters, IEEE Trans. Nucl. Sci. NS-16, 3, 29 (1969).

3. U. Tallgren, MPS/Int. LIN 66-8 (1966).
4. C.D. Curtis et al., Particle Accelerators, 1, 3-109 (1970).
5. As designed for the proposed 70 MeV NIMROD injector, H. Wroe et al., RHEL/R 226 (1971).
6. B. Vosicki et al., Proc. 1966 Linear Accel. Conf., LA-3609, 344-54 (1966).
7. P.H. Rose, Nucl. Instr. & Meth., 28, 146 (1964).
8. C.R. Emigh et al., Proc. Sym. on Ion Sources and Formation of Ion Beams, BNL-50310, 113 (1971). See also IEEE Trans. Nucl. Sci. NS-16, 3, 46 (1969).
9. P.A. Chamouard, Proc. Sym. on Ion Sources and Formation of Ion Beams, BNL-50310, 107 (1971).
10. L. Bex et al., Proc. 1st International Conf. on Ion Sources, Saclay, 191 (1969).
11. B. Kuiper, private communication (1972).
12. Th. Sluyters et al., Particle Accelerators, 1, 15-25 (1970).
13. S. Fukumoto et al., to be published in Proc. of the 1972 Los Alamos Linear Accelerator Conference.
14. V. Kovarik et al., Proc. Sym. on Ion Sources and Formation of Ion Beams, BNL-50310, 21 (1971).
15. A. Septier, Proc. Sym. on Ion Sources and Formation of Ion Beams, BNL-50310, 9 (1971).

TABLE I

PARAMETERS FOR ION SOURCES FOR PROTON LINACS

		Batavia	Chilton	Geneva	Los Alamos	Saclay	Serpukhov	Upton	Chicago
Cathodes	Cathode Type	Oxide	Oxide	Oxide	Oxide	Oxide	Hot Filament (Ta)		Oxide
	Cathode Power (W)	60	-	250	25	50	1000	75	75
	Cathode Life (h)	-	-	>2000	>3000	6000	1000	3000	8000
Discharge-Parameters	Snout Channel (diam. x length) (mm)	5 x 1.6	5 x 11	5 x 10	4.5 x 11	5 x 10	4 x 7	5 x 10	5 x 10
	Snout Anode Distance (mm)	13	6.4	4	6.4	5	6.5	8	5
	Anode Aperture (mm)	1.3	0.5	1.4	0.62	0.7	1.5	1.2	0.75
	Gas Pressure (Torr)	0.15	0.4	0.8-1.0	0.3	0.5	0.5	0.5	0.10
	Gas Consumption (cm ³ atm/min)	2.5	-	~35	-	1.6	1-3	5	~1
	Arc Current (A)	40	40	70-75	8-16	18	30	28	40
	Arc Voltage (V)	230	-	120	100-180	110	200	120	150-250
	Snout Voltage (V)	70	-	60	-	50	60	50	-
	Max. Magn. Field (kG)	3.0	-	4.0	2.0	7	3.0	2.5	3.0
Expansion Extraction Geometries	Plasma Expansion Cup (exit diam. x length) (mm)	27 x 75	20 x 15	20 x 34	14 x 9	10 x 26	94 x 150	22 x 31	13 x 23
	Cup Extractor Distance (mm)	30	~17.5	18	25.4	20	17	14.5	-
	Extraction Geometry	"Pseudo" Pierce	-	-	"Exact" Pierce	Pierce	-	"Pseudo" Pierce	-
	Extraction Voltage (kV)	43	50	45	27	35	15	40	-
Beam Qualities	Operational Ion Current (mA) for () mA Linac Beam	~250(100)	170	~450-500 (100)	48(17)	48(20)	300(75)	250(75)	150(40)
	Proton Percentage (%)	85	-	80-85	75-80	85	75	>75	75
	Emittance* (m x rad) x 10 ⁶	0.8	0.7	0.5	0.25	0.2	1.0	<1.2	0.6
	Density† (A/m x rad) x 10 ⁻⁶	0.30	0.24	0.90-1.10	0.19	0.24	0.30	0.20	0.25
	Brightness‡ (A/m ² x rad ²) x 10 ⁻¹⁰	0.78	0.81	3.6-4.4	1.53	2.4	0.6	>0.34	0.83
	Pulse Length (μsec)	20	170	20-140	500	500	10-50	100	200
Repetition Rate (Hz)	15	1.2	2	120	0.5	0.1	10	0.25	

*Emittance = Area x β_y, †Density = Intensity/Emittance, ‡Brightness = 2 Intensity/(Emittance)²

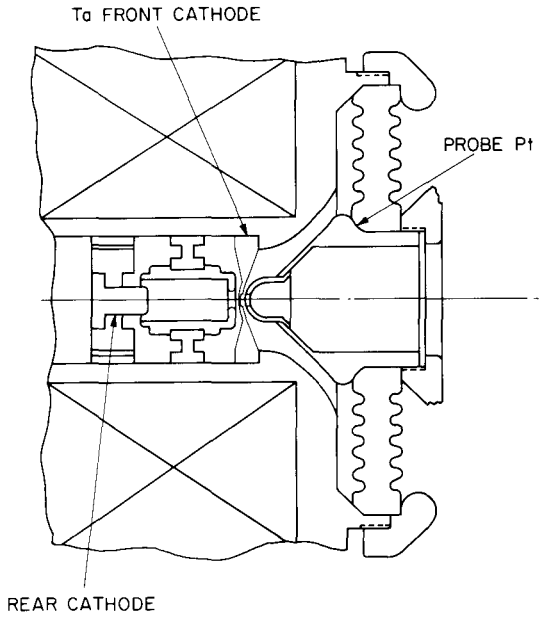

Figure 1

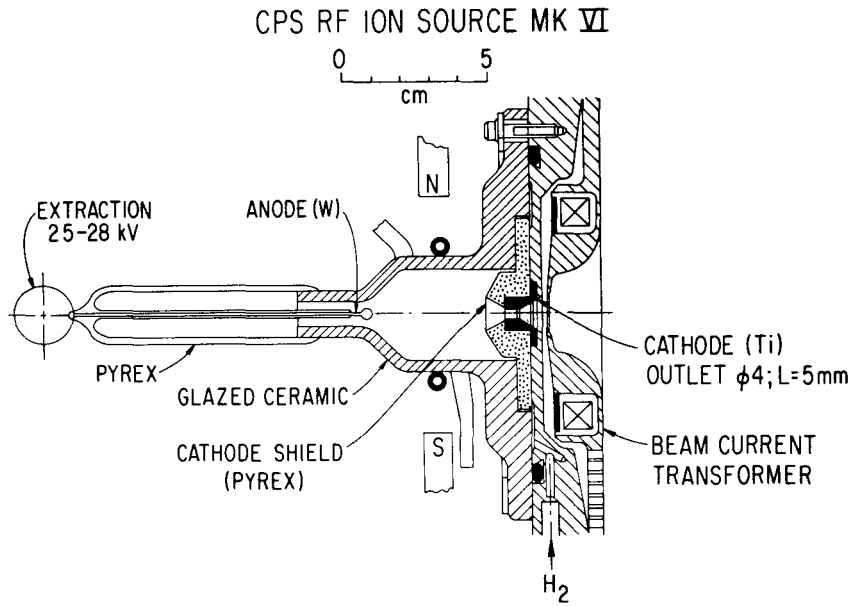

Figure 2

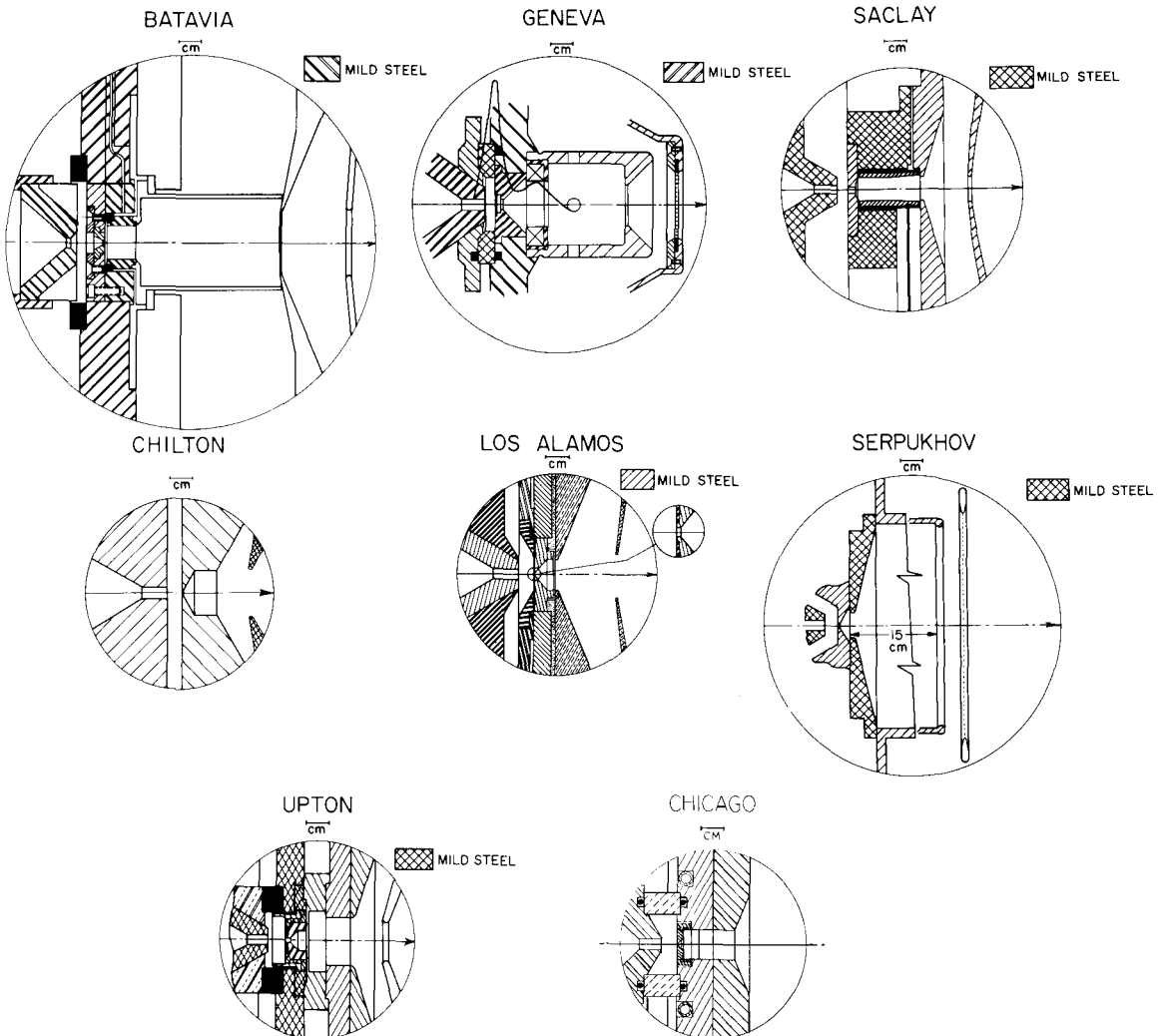

Figure 3

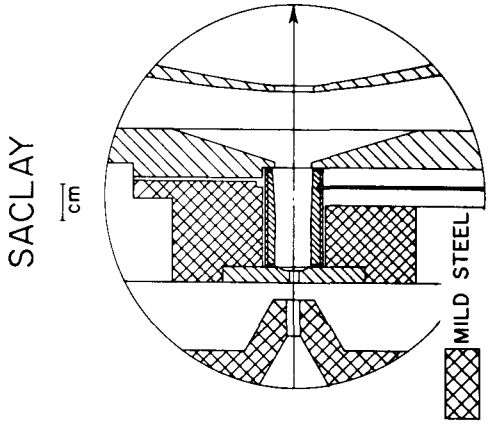

Figure 8

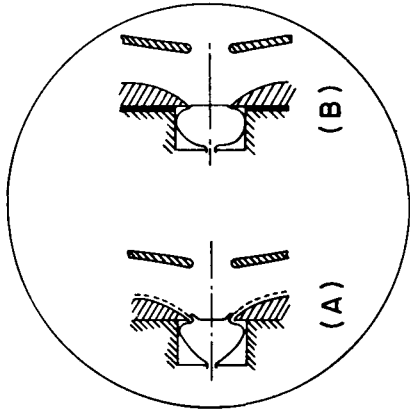

Figure 7 a and b

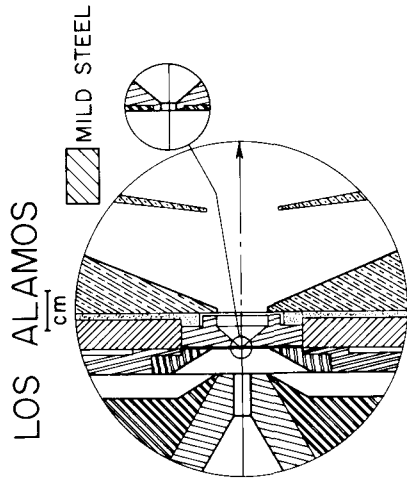

Figure 7

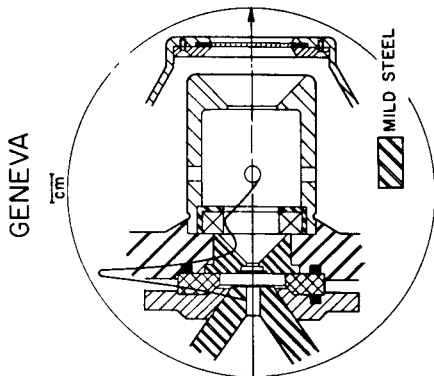

Figure 6

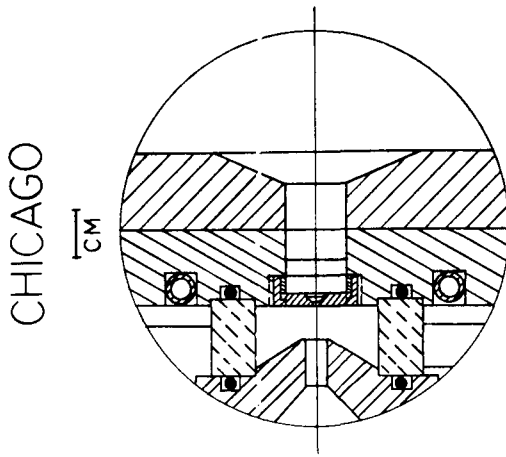

Figure 12

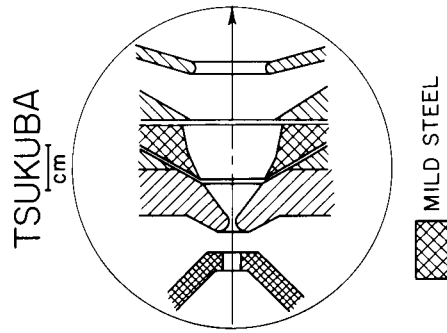

Figure 11

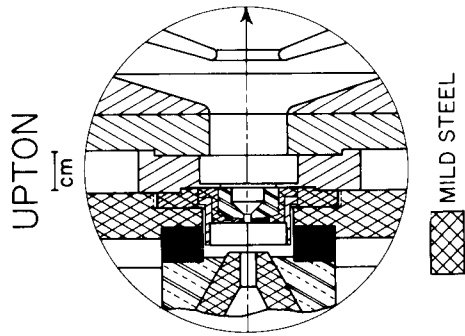

Figure 10

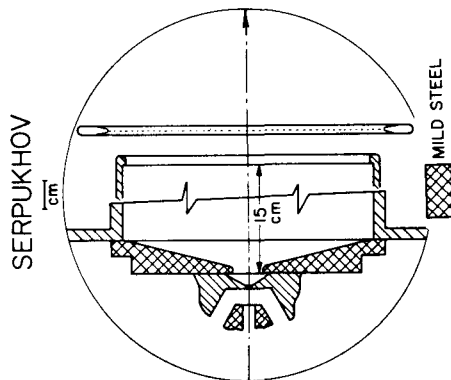

Figure 9

DISCUSSION

Parker, Argonne: You mentioned that a reasonable goal for an H^- source would be 25 mA. The normal H^+ injection for, say, the AGS is on the order of 100 mA, giving an injection efficiency improvement of only 4. Wouldn't 10 or 20 be more like it?

Sluyters, BNL: I agree.

McKibben, LASL: We've been interested in using the Osher extraction on the polarized ion source for some time. We have tried a small version of the multiple aperture with respect to our source. George Lawrence has played an important role in that. Unfortunately, our results have been very poor. So have similar results at TUNL by Tom Clegg. We don't understand what is wrong. There seems to be something which is going on which Osher has overcome that we have not. Our suspicion is that this has to do with plasma oscillation and, consequently, space charge neutralization.

Curtis, NAL: The nice work in Japan with the nozzle plasma expansion cup is very interesting. The result on constant brightness with increasing beam current is in contrast to our results with a different type of cup in which the emittance remains constant with beam current.

Miller, SLAC: I'd like to make a plea that units of length times rest mass times the velocity of light be used to express normalized emittances. It is easy to forget, after a time, whether an emittance is normalized or not. When you multiply by $\beta\gamma$, you are expressing the radial momentum in units of M_0C . So, by expressing the emittance in this way, it becomes evident that it is normalized.