

CONSTRUCTION OF ALUMINA INSULATED
BENDING MAGNETS FOR LAMPF*

E. D. Bush, Jr. and R. L. Rhorer
University of California
Los Alamos Scientific Laboratory
Los Alamos, New Mexico

Abstract

The fabrication techniques and operating characteristics of three small bending magnets utilized in the LAMPF accelerator are presented. All three magnets are necessarily small as dictated by various boundary conditions; however, each utilizes a different design philosophy to satisfy its particular requirements. One is required to withstand a 1500°F H₂ furnace brazing temperature, another is required to fit within a half drift tube. The last consists of two bending magnets in a common iron core assembly, with a very high conductor current density and severe space limitations. The operating parameters are tabulated. All magnets described herein are virtually radiation hard.

I. INTRODUCTION

This report describes three small magnets used in the 201.25 MHz drift tube linac and transition region that are rather unique in their design and fabrication. They are constructed of virtually radiation-hard materials and have quite high packing factors. No new processes were developed; but established coating methods such as porcelainizing, flame-spraying, arc-spraying, and metalizing ceramic were applied to magnet fabrication. Application of these processes to each of the magnets is described along with the design criteria, assembly, testing, and operating characteristics.

II. DRIFT TUBE STEERING MAGNETS

A. Description

Vertical and horizontal steering magnets were required in ten specific locations in Tanks 3 and 4 of the drift tube linac. Alternate drift tubes in these tanks contain quadrupole magnets while the remainder are empty.

Steering magnets that would satisfy the required field of $\int B dl = 1500 \text{ G cm}$ were designed and fabricated at LASL for the appropriate drift tubes.

Tests of prototype steering magnets revealed an appreciable field distortion when both vertical and horizontal components were energized simultaneously due to nonuniform distribution of the coil on the return yokes. Considerable experimental work was performed modeling mitered joints, overlapped joints,

coil displacement, square conductor, and foil wound coils to determine the resulting field quality. Single component field steering magnet designs were selected on the basis of the modeling studies.

While this design requires a few turns and, consequently, has a relatively high current, it does have a high packing factor and results in a brazable, radiation-hard, magnet.

B. Iron Core Design

The physical size of the steering magnets was governed by the inside dimensions of the shortest drift tube requiring a steering magnet.

Steering magnets are provided to correct the beam position error caused by magnetic aberrations or alignment errors and, ideally, will operate at very low or no field. ARMCO ingot iron was used for the core structure to minimize the residual fields.

Copper support struts extend from the magnet core to the inside of the drift tube body for conduction cooling. To minimize cost, standard parts were used to fabricate drift tubes housing the steering magnets. Assembly brazing was accomplished in the same manner as that used for the other drift tubes. Consequently, the steering magnet had to be constructed to survive the high temperatures used for brazing.

Inorganic materials such as metals, porcelain, and ceramic that withstand temperatures of this magnitude are also virtually radiation hard.

Plating and porcelainizing processes utilized

*Work performed under the auspices of the United States Atomic Energy Commission.

are essentially the same as those used for the drift tube quadrupole magnets. A coating of 0.0005 in. thick Watts nickel plate was applied to the external portions of the yokes to protect the machined surfaces from oxidation. Other plating processes were evaluated but failed to hold up during the furnace brazing evolution. The return yokes were coated with Chicago Vitreous Corp. LS-13290-B slip, dried, and fired at about 1800°F, resulting in a porcelain coating approximately 0.003 in. thick and having a coefficient of expansion very closely matching that of the ARMCO ingot iron. The return yokes were left slightly over-size to permit final surface grinding for an optimum fit. The porcelain coated return yokes provided a ground insulation in addition to that on the coil.

C. Coil Design

The coil design selected was made up of twenty individual turns of OFHC copper machined from sheet stock. A diagonal slot milled in the side of each turn forms the transition area, so that when connected they form one coil section as shown in Fig. 1. The individual turns are masked in the area of the turn-to-turn connection, coated with flame-sprayed molybdenum to improve the bond of the arc-sprayed alumina. The completed coating results in an insulation having a thickness approximately 0.003 in. thick. The coating provides a durable insulation that is not affected by the brazing temperatures.

D. Magnet Assembly

The turns are furnace brazed together in the areas that were masked prior to coating. In addition to electrical insulation, the alumina coating also serves as a barrier to prevent bridging of the alloy during the brazing operation. Each coil section is brazed to the coil lead that passes through the drift tube stem. The leads are connected to the coil section in such a manner that they do not form a turn around the beam pipe (see Fig. 2). Standard two-hole thermocouple insulators separate the leads and insulate them from the inside of the drift tube stem.

The drift tube assembly was brazed in the following steps:

<u>Brazing Operation</u>	<u>Temperature</u>
Coil sections	1820°F
Steering magnet in drift tube body	1450°F
Stem to drift tube body	1450°F
Drift tube repair, if required	1385°F

"Hi-pot" voltages of 800 V to ground served to verify the proper insulation while axial and transverse field surveys were made at design current to confirm proper assembly, symmetry and turn-to-turn insulation.

E. Operating Characteristics

The operating characteristics of the steering magnets are shown in the table.

III. TRANSITION REGION BENDING MAGNETS TR-BM-01, 04

A. Description

The bending magnet (TR-BM-01) located at the exit end of the drift tube linac separates the positive and negative ion beams and causes each to bend approximately four degrees. (Figure 3) After other alterations in the trajectory of the beams, another bending magnet (TR-BM-04) repositions the beam on the accelerator centerline. The first bending magnet is located within the last half drift tube of the linac and, therefore, its size is limited by the space available.

Because of the severe size limitations, a picture frame design was selected. Also, the size limitations require a high packing factor. Water cooling was necessary, requiring a rather large conductor with relatively few turns. While a coil with a low number of turns inherently has a high packing factor, it does require more current and, consequently, larger power supplies. In our design we attempted to produce a feasible magnet design that did not require unnecessarily severe power supply characteristics. Four magnets (TR-BM-01, 02, 03, 04) were designed with the same number of turns and iron length to permit series operation on one power supply with shunts provided for fine current adjustment on each magnet.

B. Iron Core Design

Using the physical boundary conditions imposed by the space available within the half drift tube and around the tapered bore tube, the maximum allowable size was established. The iron core was sized to operate at a reasonable flux density and still provide sufficient space for the coil assembly.

The completed magnet can fit within a cylindrical envelope 5 in. in diameter and 11 in. long. ARMCO ingot iron was used for the core structure to reduce the residual magnetic fields. The assembly was designed to be supported and aligned from the lower yoke (TR-BM-04 only). Because the assembly

is doweled, it can be completely disassembled from the top for maintenance, then reassembled without requiring realignment.

Nickel plating was used on the iron core exterior to prevent rusting and arc-sprayed alumina was applied to the interior and on the beam pipe for ground insulation.

Reamed holes in the top yoke accept tooling balls for alignment of TR-BM-04 in the beam line.

C. Coil Design

Space limitations prevented the use of conventional wound coil construction. Square, hollow sections were used for the coil sides, and drilled, plugged plates formed the ends (Fig. 4). The coil configuration consists of an upper and lower coil section, each having four turns. OFHC copper was used for the coil assembly to permit assembly using hydrogen furnace brazing techniques. Each turn forms one water circuit in order to satisfy the stringent cooling requirements. Assembly was performed in steps and the joints were helium leak checked and water-flow tested before proceeding to the next braze evolution. Small metalized alumina discs positioned in shallow recesses served as insulators between turns and provided a fixturing method to hold the subassemblies in place during the final assembly braze (Fig. 5). Each step braze used alloys with progressively lower melting temperatures, as shown in Fig. 6. Helium leak checks and water-flow tests were used to confirm the integrity of the completed assembly.

At this point in the fabrication sequence, the coil was impulse tested to verify that there were no turn-to-turn shorts.

Arc-sprayed alumina was applied directly to the exterior areas of the coil sections to provide ground insulation (Figs. 7 and 8).

D. Magnet Assembly

The iron core and beam pipe are assembled and the connection made between the two coil sections. At this point, the assembly is hi-pot tested to check the coil to ground insulation.

Installation of the water fittings and thermal switches complete the magnet assembly. Bending magnet TR-BM-01 is inserted in the housing that fits within the half drift tube (Fig. 9) and aluminum covers are installed over the exposed portion of the

coils on TR-BM-04 (Fig. 10).

In addition to flow tests and hi-pot tests, axial and transverse magnetic field measurements were made to check uniformity at the electrical operating parameters.

The operating characteristics are shown in the table.

IV. TRANSITION REGION MAGNETS TR-BM-02 and 06

Two bending magnets close together were required to further separate the positive and negative ion beams after the initial splitting by bending magnet TR-BM-01 at the start of the Transition Region. These two magnets are designated TR-BM-02 and TR-BM-06 and were built in a common yoke. An identical pair of magnets were required further downstream to recombine the beams, which are called TR-BM-03 and TR-BM-08.

The design requirements and operating parameters of the magnets are listed in Table I. To provide as uniform a field as possible, the magnets were designed as picture-frame type magnets. The core was fabricated from ASTM A-7 steel and nickel plated. A completed core is shown in Fig. 11 with the top yoke removed. The top and bottom yoke pieces were ground flat and the three return yoke pieces were ground in the same setup to insure parallelism of the top and bottom yokes. The assembly was designed, as mentioned previously for TR-BM-04, to allow removal of coils and beam pipes without upsetting the alignment of the core.

The coil dimensions were dictated by the clearance between beam paths at the upstream end of the magnets. Considering coil construction difficulties and power supply requirements, an eight-turn coil for TR-BM-02 and a twelve-turn coil for TR-BM-06 were selected. The space between beam paths was limited to about 0.8 in. at the coil location of TR-BM-06; therefore, this coil was built as a septum-type coil with smaller conductors on one side.

The fabrication sequence for these coils was to machine the coil parts to size, braze together the parts to form individual turns, insulate the turns with arc-sprayed alumina, and assemble the insulated turns into a completed coil. The conductor is 5/16 in. square with a 1/8 in. diam hole. The conductor pieces were machined to the proper length and joints were prepared as shown in Fig. 12. The end crossover pieces were machined from a solid block with the

water passage holes drilled. The joints were torch brazed using Easy-Flo 45 alloy and flux. After brazing, each turn was water-flow checked and then leak checked with a mass spectrometer leak detector.

After brazing and testing, the individual turns were flame-sprayed with a molybdenum subcoat about 0.003 in. thick and then arc-sprayed with an alumina coat about 0.003 in. thick for insulation. The four turns are shown in Fig. 13 after the alumina coating has been applied. This insulation method was developed by the ceramic section at LASL to withstand furnace brazing as required for the drift tube steering magnet described earlier in this report. Because these coils are not furnace brazed, some conductors have also been insulated with the arc-sprayed alumina directly on the copper conductor. Although the alumina chips off easier without the molybdenum subcoat, this method provides good electrical insulation and a little more room between turns which is helpful during assembly.

The insulated turns nested into half a coil are shown in Fig. 14. The connections between turns are provided by copper blocks soldered onto the conductors with soft silver solder (96.5% tin - 3.5% silver). These connection blocks also provide the water connections and a thermostat mounting. Each turn is an individual water circuit with a thermostat for every two turns.

The twelve-turn coil of TR-BM-06 was fabricated in a similar manner with the added complication of a septum-type coil and more turns. Both coil sections are shown in Fig. 15, with the turns nested together. The conductor on the side of the coil between the beam paths is 3/16 x 5/16 in. tubing stacked two wide and six deep. The conductor on the outside is 5/16 in. square and stacked three wide and four deep.

Both completed coils are shown in Fig. 16, placed in position in the core without the beam pipe. The top and bottom coil sections of both coils are electrically connected with a bolted joint for ease of assembly. The assembled magnet without beam pipe and water manifolds is shown in Fig. 17.

V. CONCLUSION

The fabrication techniques described have not yet received widespread use; however, they do lend themselves to small magnet construction, as shown in Fig. 18. Relatively high coil packing factors

can be achieved, the assemblies are essentially radiation hard, and the magnets can withstand repeated furnace brazing cycles.

There are disadvantages. All of the inorganic insulators described are brittle; consequently, physical blows, or thermal shocks can prove detrimental. Also, the inherent porosity of the arc-sprayed alumina has the disadvantage of permitting moisture, resulting from water spills, to penetrate the coating, lower the electrical resistance, and cause corrosion of the conductor.

ACKNOWLEDGMENTS

The Ceramics Section of CMB-6, under the direction of S. Stoddard, provided the expertise in the fields of porcelainizing, metalizing ceramic, flame-spraying and arc-spraying. These individuals include J. Rosenthal, R. Cowan, H. Richerson, L. Vaughan, D. Roybal, H. Clifton, P. Paiz, G. Carter, L. O'Neil, and C. Gladwell.

E. Schneider worked extensively on the steering magnet model studies, constructed hi-pot and impulse test equipment, established the testing procedures, procured power supplies, and designed the shunt and control systems.

H. Worstell, S. Koczan and G. Suazo assisted with the braze joint design and developed the procedure on the various coils and assembly in the drift tubes.

E. Colston and V. Hart worked very closely with us on the tooling techniques required to achieve the close alignment tolerances and performed the final installation and alignment.

P. Stroik and R. Harrison performed the design drafting for these magnets. F. Trujillo, V. Armijo, and G. Gonzales contributed to the completion of the magnets by machining and fitting many of the bending magnet coil parts. W. Romero and P. McClellan built prototypes, performed tests, and after the development phase, constructed the final magnets. Their demand for excellence yielded components that have logged many hours of operation.

TABLE I
MAGNET PARAMETERS

	Drift Tube Steering Magnet	Magnet Designation		
		TR-BM-01&04	TR-BM-02&03	TR-BM-06&08
Field (kG)	0.100	4.5	4.8	11.3
Iron Length (cm)	15	20	20	34.13
Vertical Gap (cm)	3.5	3.5	3.5	3.5
Width (cm)	3.5	3.5	3.5	3.5
Number of Turns	20	8	8	12
Current (A)	27	1650	1650	2700
Voltage (V)	0.22	2.7	3.5	15.5
Power (W)	5.9	4450	5770	41800
Current Density (A/in ²)	1066	19400	19400	58000
Number Water Circuits	None	8	8	12
Water Pressure Drop (psi)	----	60	60	120
Water Flow Rate (gpm)	----	5.8	4.9	14.3
Water Temperature Rise (°F)	----	5.3	8	20
Water Velocity (ft/sec)	----	19	16	31



Fig. 1 Typical conductor connection, drift tube steering magnet

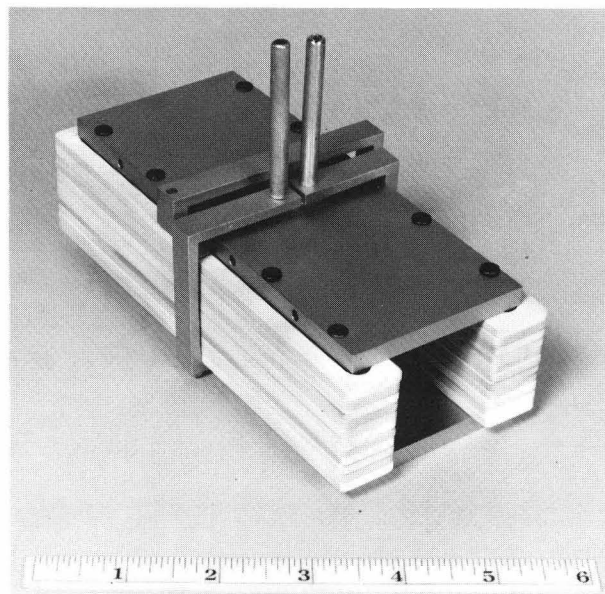

Fig. 2 Drift tube steering magnet assembly

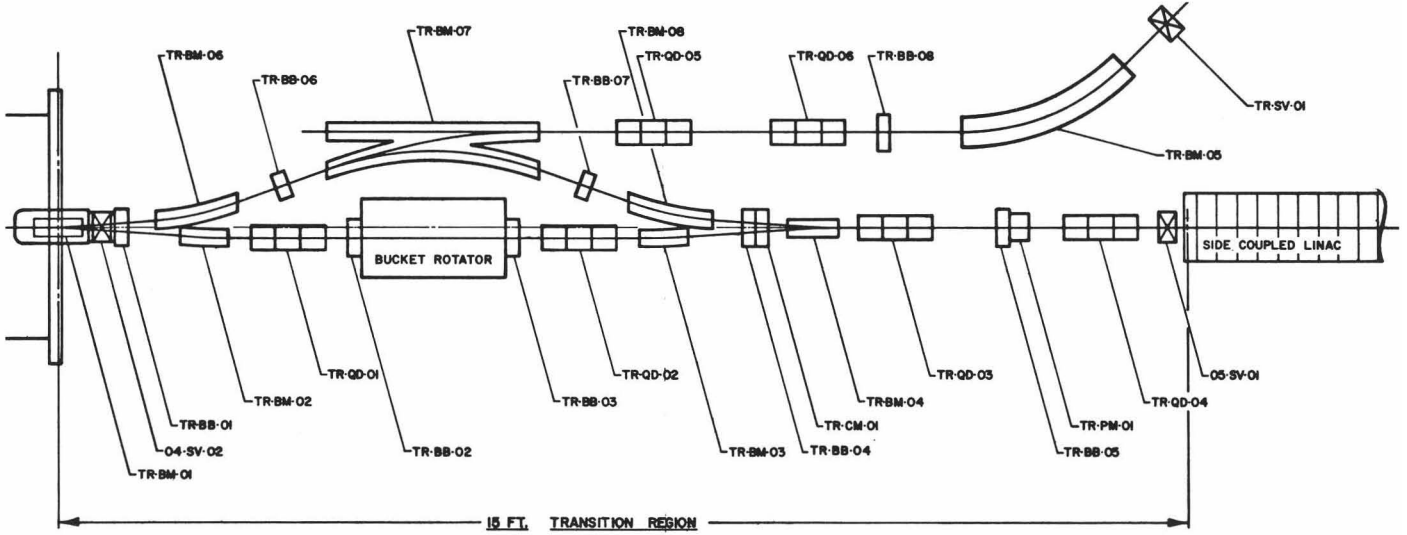

Fig. 3 Transition region layout

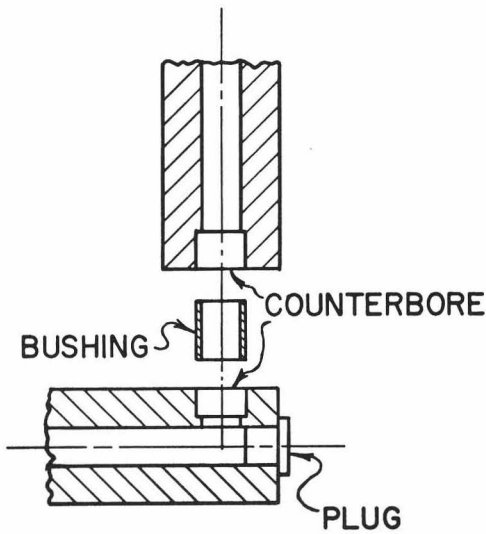

Fig. 4 Typical coil braze joint, TR-BM-01, 04

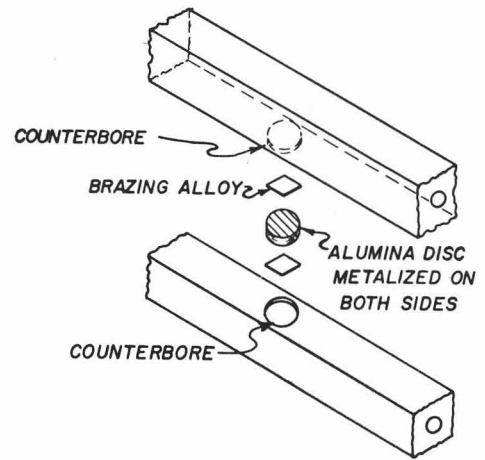

Fig. 5 Typical conductor insulator and fixturing device, TR-BM-01, 04

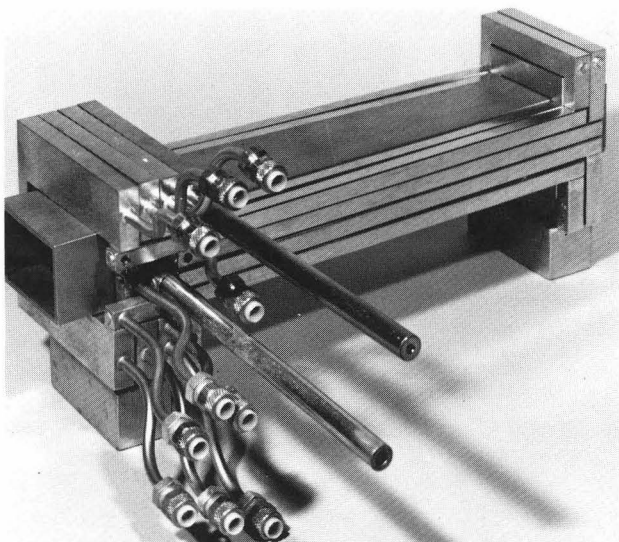

Fig. 6 Brazed coil assembly, TR-BM-01, 04

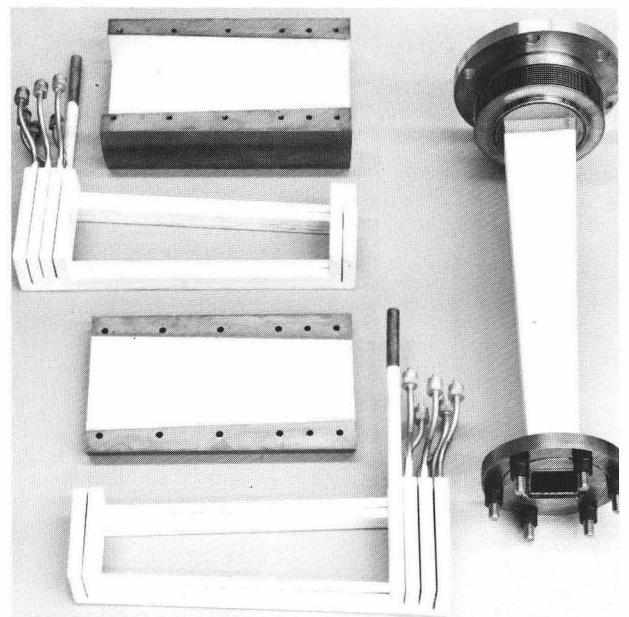

Fig. 7 Magnet components, TR-BM-01, 04

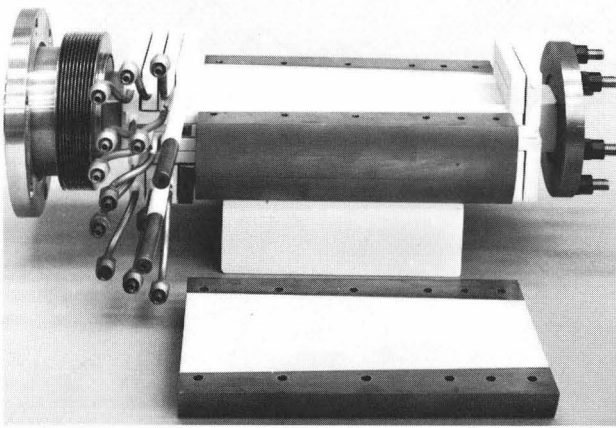

Fig. 8 Magnet partial assembly, TR-BM-01, 02

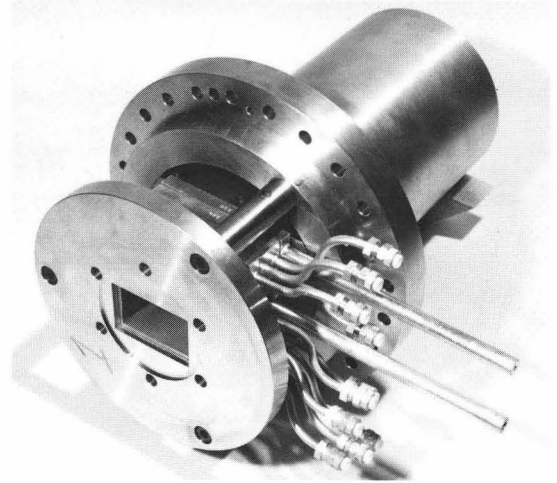

Fig. 9 Magnet assembly, TR-BM-01

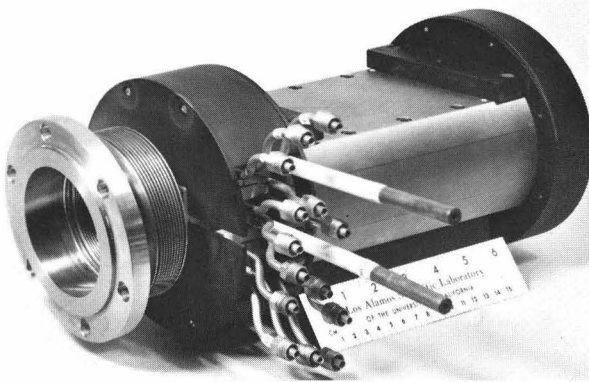

Fig. 10 Magnet assembly, TR-BM-04

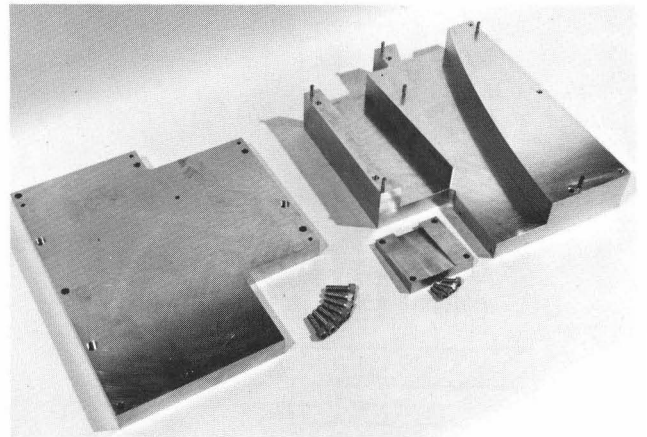

Fig. 11 Magnet core, TR-BM-02,06

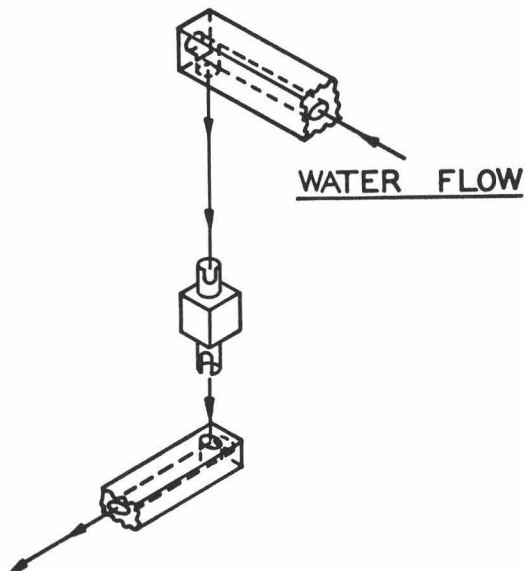

Fig. 12 Typical braze joint, TR-BM-02, 06

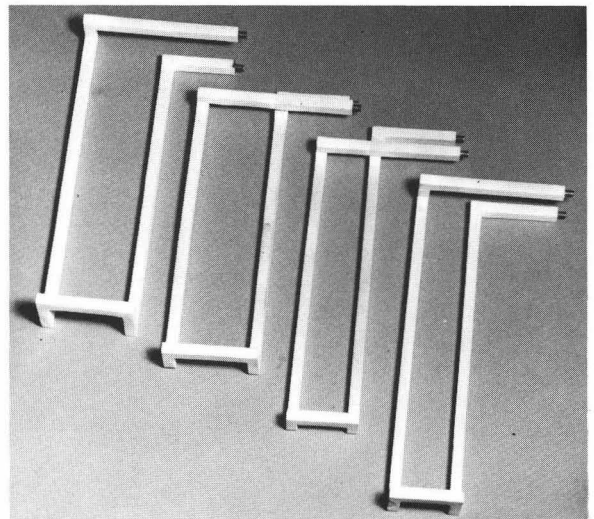

Fig. 13 Insulated coil turns, TR-BM-02

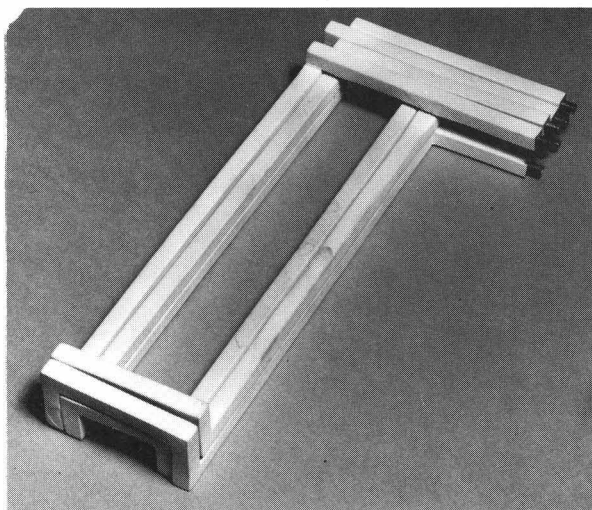

Fig. 14 Half coil assembly, TR-BM-02



Fig. 15 Coil assembly, TR-BM-06

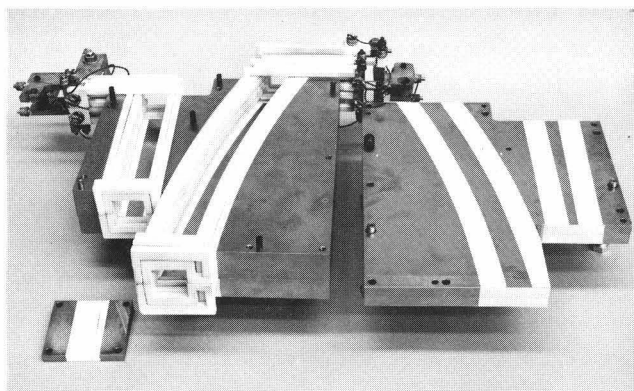

Fig. 16 Magnet partial assembly, TR-BM-02. 06

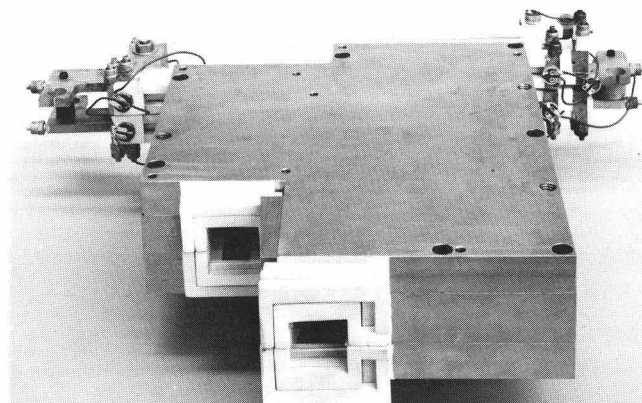

Fig. 17 Magnet assembly, TR-BM-02, 06

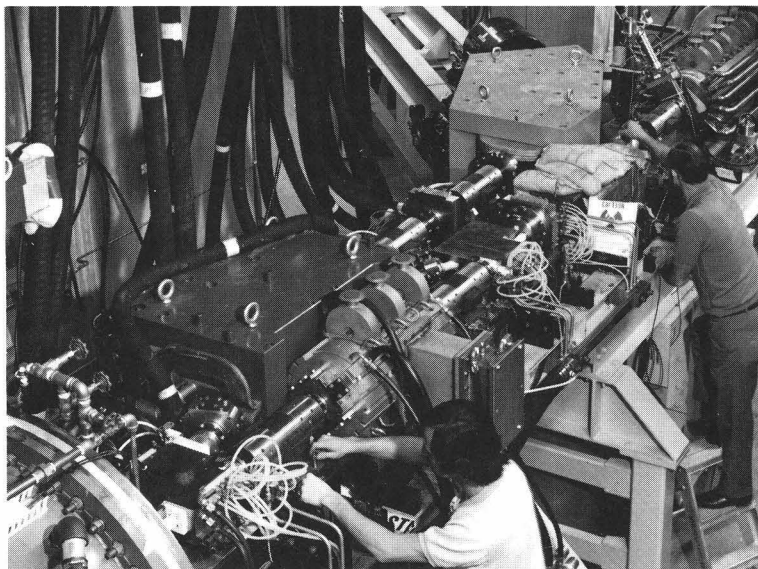

Fig. 18 Completed transition region