

DEVELOPMENT OF A HIGH-CURRENT DEUTERON INJECTOR FOR THE FMIT FACILITY\*

J. D. Schneider, H. L. Rutkowski,<sup>†</sup> E. A. Meyer, D. D. Armstrong, B. A. Sherwood and L. L. Catlin  
 Los Alamos Scientific Laboratory  
 Los Alamos, New Mexico 87545

Summary

The injector for the Fusion Materials Irradiation Test (FMIT) Facility has been designed to deliver a 100-keV, 125-mA dc deuterium beam (Fig. 1). A prototype injector has been built to run with a H<sub>2</sub><sup>+</sup> ion beam. Two ion sources are being tested—one with magnetic-cusp geometry. The injector transport consists of a single-stage modified Pierce-extractor, a double-focusing 90° analyzing magnet, a high-power emittance scanner, steering and quadrupole focusing magnets, a mechanical beam-current modulator and a deflection type beam pulser. The performance of the prototype injector is discussed.

Introduction

A preprototype test stand has been used to generate the design of a 100-keV, 125-mA dc deuterium beam injector for the FMIT facility. An ion source of Osher design and three of cusp-field geometry were fabricated. A single-aperture extraction system was designed using the beam extraction code SNOW.<sup>1</sup> Because no operational differences were predicted, single-gap extraction was chosen over the two-gap system that originally was considered. Magnetic beam analysis is used to select the desired ion species in the beam from the ion source-extractor system. The tests of these systems, as

well as tests of the vacuum pumping and remote control systems, are discussed below.

Both calculation and tests have shown that very good quality beams can be achieved by sizing the aperture diameters such that operation is at 60% of the space-charge limit and by using electrode profiles based on the space-charge-limited "Pierce" geometry. A key factor in minimizing space-charge divergence of the beam was the installation of a negatively biased (-1 kV) electron trap only 0.15 cm downstream from the ground electrode. At a similar distance downstream from the electron trap, a hollow cylinder was used to re-establish ground potential and thus enhance, in a very short distance, space-charge neutralization of the drifting beam.

Ion Source

Initial tests were performed on a Los Alamos Scientific Laboratory (LASL) version of the Osher design reflex-arc source. This unit originally was built by the Lawrence Livermore Laboratory (LLL) for another program at LASL and was delivered as a multiaperture source. It was converted to a single-aperture source with improved extraction optics. Although it delivered the required current density easily, a plasma instability developed that would seriously affect linac operation.

Three versions of cusp-field ion sources have been built and tested. Mark 1 was a relatively large (18-cm dia. by 31-cm long) water-

\*Work performed under the auspices of the U. S. Department of Energy.

<sup>†</sup>Westinghouse/Hanford Engineering Development Laboratory employee working at the Los Alamos Scientific Laboratory.

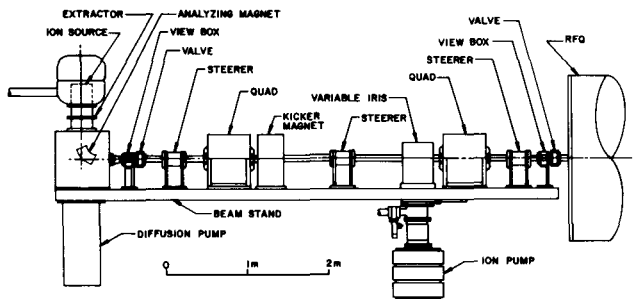

Fig. 1 Proposed FMIT injector system.

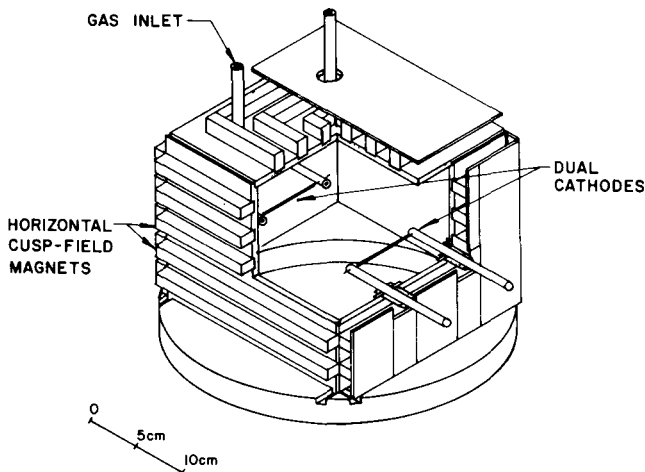

Fig. 2 Mark 2 cusp-field ion source.

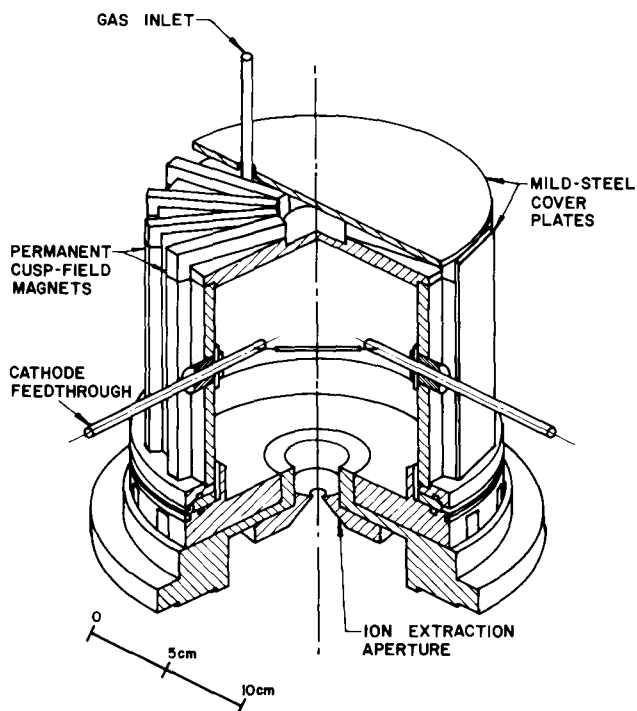

Fig. 3 Mark 3 cusp-field ion source.

cooled cylindrical chamber. Thirty permanent magnets were installed, on the curved walls only. Operational stability was impressively good, but excessive ion losses to the noncusped end walls made it impossible to achieve an adequate ion density. The next version, Mark 2 (Fig. 2), featured simplicity and low cost, and reduced the ion loss area to one-quarter that of Mark 1. This was a nearly cubical chamber (18 cm per side) with five horizontal rows of magnets along the sides and three rows of magnets providing a cusped field on the top plate. Performance of Mark 2 was approximately five times better than its predecessor and easily delivered the required current density. Gas efficiency was very high (>40%), but the ion-species ratio still needs some improvement.

In an attempt to reduce ion losses even further, Mark 3 (Fig. 3) has been constructed with cusp-field magnets on both top and bottom plates, as well as on the cylindrical side walls. Initial tests showed that performance was not as good as with the Mark 2 source. All results reported pertain to the Mark 2 source.

Two major problem areas with the cusp ion sources have been the directly heated cathodes and the cathode feedthroughs. Several years of good experience with flat nickel-gauze oxide-coated filaments in a duoplasmatron ion source provided the incentive to try a similar-type filament on the cusp source. However, under conditions of high-plasma density, it was

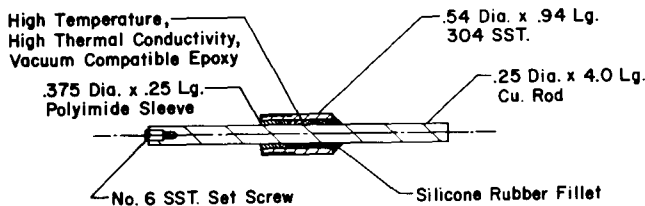

Fig. 4 Ion source cathode feedthrough.

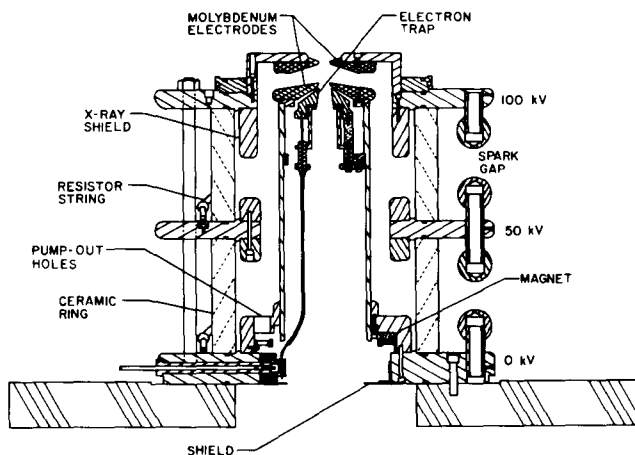

Fig. 5 The 100-kV extractor.

impossible to achieve long lifetimes. A successful new cathode geometry consists of a 1.0-mm tantalum wire tightly wrapped with 0.1-mm nickel gauze and coated with a barium-strontium oxide. Spot welding the nickel gauze to the tantalum wire was found to improve lifetime somewhat.

Many designs of filament feedthroughs were tried before the present concept evolved. Commercially available vacuum-compatible high-current electrical feedthroughs utilizing ceramic insulators invariably failed with destructive arcs that originated on the vacuum surface of the ceramic. Organic insulators (nylon, epoxy, Kel-F) held up better in the arc environment, but could not withstand the high temperatures without the use of complicated cooling devices. The design currently in use (Fig. 4) employs four separate insulating materials. It has resulted in a high-current feedthrough that is a simple one-piece construction, low in cost, very compact, and that is reliable in the high-temperature arc environment.

#### 100-kV Extractor

The 100-kV extractor is a single-gap accelerating column as shown in Fig. 5. Externally, it consists of two 20.3-cm-id by 12.7-cm-long

alumina insulating rings sealed with O-rings between three annular 38.1-cm od stainless steel plates. Voltage grading is provided by a 0.67-mA resistor string and arc protection is furnished by atmospheric spark gaps. This initial design utilizes an aperture (1.13-cm dia.) of one-half the area anticipated for use in the FMIT extractor. Design current for this half-area aperture is 100 mA at 100 kV, which results in the same current density as required for the FMIT extractor.

Careful attention has been given in the design to minimize high-voltage breakdown across the insulators, caused mainly by photoelectric charging from x-ray impingement, that is normally a problem in high-voltage extractors of high-average current. The x-rays (bremsstrahlung) are caused by electrons, accelerated in the gap, striking the 100-kV surface. The electrons are produced by beam-induced ionization of the residual gas in and downstream of the accelerating gap. Specifications for the FMIT extractor require that voltage breakdown be limited to less than one per eight hours.

Design features to minimize breakdown are as follows:

1. The maximum gradient in the acceleration gap is 50 kV/cm.
2. Flashover across the ceramic insulating rings is inhibited by the use of long insulators divided into two sections to limit the voltage across each section to 50 kV.
3. Reentrant geometry is used at the inside corner of the insulating rings to keep the electric field low at these critical points.
4. The insulating rings are shielded from x rays by 2-cm-thick steel rings and by the molybdenum electrodes.
5. An electron trap biased at -1 kV is used to prevent entry into the gap of electrons formed downstream of the acceleration gap.
6. Low residual gas pressure in the acceleration gap is obtained by use of a 10,000-ℓ/s oil diffusion pump and sixteen 1.9-cm dia. pump-out holes in the extractor. Low pressure here is of critical importance because it is the only way to reduce the x-ray level caused by electrons formed in the gap because of beam-induced ionization.
7. An array of permanent magnets producing a transverse 500-G magnetic field at each pump-out hole prevents electron backstreaming through these holes into the high field region.

The grounded molybdenum electrode is attached to a 10.0-cm od tube that can be adjusted axially to obtain the required gap spacing. This tube and the x-ray shield ring are made of mild steel; they help to shield the extraction area from any stray magnetic fields.

The stainless steel electron trap is attached by insulators to the inside of the tube with the electrode surface 0.15 cm from the 0-kV molybdenum electrode. A grounded shield placed

a similar distance below the electron trap electrode reduces field penetration into the region below. A coaxial lead is used to supply -1 kV to the trap so that the beam will be shielded from the field of this conductor. The beam-line region below the electron trap must be kept free of electric fields so that a high degree of space-charge neutralization of the beam will occur and reduce beam divergence.

The effectiveness of the electron trap and of these precautions is quite pronounced and is shown for a 95-mA beam at 100 kV in Figs. 6a and 6b. Figure 6a shows the diameter of the beam 1.0 m below the 0-kV electrode (analyzing magnet off) as a function of electron trap voltage. With -1 kV on the trap, the beam is 2.0-cm dia. as compared to the 1.13-cm dia. aperture in the molybdenum electrodes. With the trap off, the beam spreads out to >15-cm dia. Figure 6b shows the effectiveness of the electron trap in reducing the x-ray level measured 1.2 m from the ion source. With 0 kV on the trap, the x-ray level is 16 mR/h as compared to 1.6 mR/h with -1 kV on the trap.

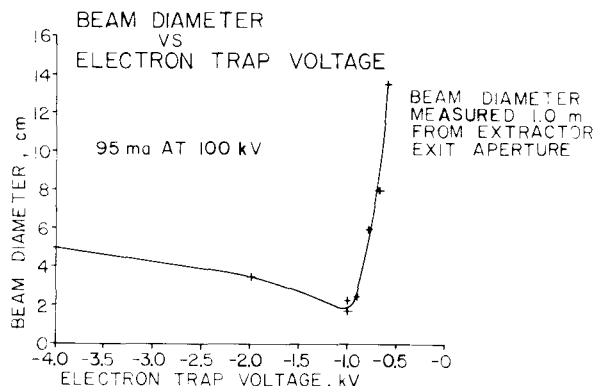

Fig. 6a Beam diameter vs electron trap voltage.

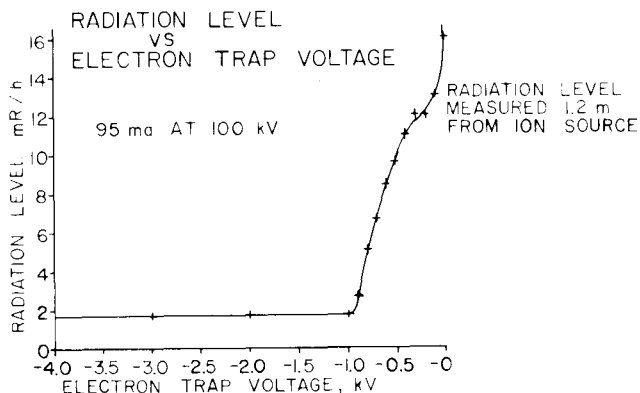

Fig. 6b Radiation level vs electron trap voltage.

#### Beam Transport

A double-focusing  $90^\circ$  analyzing magnet steers the beam into the horizontal beam line and eliminates unwanted ion species. Excitation coils, wound of hollow copper conductor and potted with a vacuum-compatible epoxy, are directly behind the pole faces. Water-cooled beam dumps protect the bottom and downstream side of the magnet box from the impingement of the unwanted species.

The analyzed beam will be tailored for acceptance by the rf quadrupole (RFQ) by two beam steerers and two magnetic quadrupole doublets. An eight-vane water-cooled variable iris structure will be used to adjust the beam current while maintaining a near-constant current density. A combination kicker magnet and beam dump will be used to provide  $H_2^+$  ion beam pulses for tuning purposes.

#### Beam Diagnostics

Beam diagnostic equipment will include three multidimensional optical beam profile monitors and appropriate beam-current monitors. Two emittance measuring devices are being built. One is a two-meter-long drift tube terminated with a water-cooled pepperpot analyzer. The other is a more sophisticated double-scanning high-power density unit for measuring detailed structure of the beam. Observation of the extracted beam (including all ion species) in the one-meter-long drift space below the extractor, assuming that only emittance contributes to beam divergence, leads to an upper-limit estimate of normalized emittance  $\epsilon_n < 0.04\pi$  cm-mrad.

#### Vacuum System

The injector vacuum system, utilizing a 10,000- $\ell$ /s oil-diffusion pump and beam-line ion pump, is described elsewhere.<sup>2</sup> Considerable attention has been given to minimizing oil contamination, which might coat the insulators and cause high-voltage breakdown in the extractor. Experience to date after 10 months of continuous operation has been very satisfactory. The system has remained clean and there is no trace of oil on the ion gauge walls. There have been no high-voltage breakdown problems in the 100-kV extractor.

#### Controls

Because the ion source and associated equipment dome must sit at a 100-kV potential, all controlling must be handled remotely. A microcomputer-based control and data-acquisition system utilizing fiber-optic links has been implemented. This system uses CAMAC hardware and is compatible with the facility control philosophy.

#### Acknowledgments

The authors wish to thank all the people who participated in setting up the injector test stand. Special thanks go to T. J. Zaugg for his work on the control system and to T. A. Stephens for much of the detailed design.

1. J. Boers, Sandia Laboratories, Albuquerque, Private Communication (1978).
2. M. D. Machalek, E. A. Meyer and L. S. Price, "The FMIT Accelerator Vacuum System," IEEE Trans. Nucl. Sci. NS-26, No. 3, 3015 (June 1979).

Discussion

West, RHEL: Do you intend to collimate the beam in the LEBT at only one longitudinal position?

Schneider: There is need to collimate it at only one position, I guess, right at the entrance of the RFQ.

West: Not if you want to maintain a constant current density, because, effectively, you are producing a beam that is not mismatched.

Schneider: Yes.

West: You have to collimate in phase space effectively.

Schneider: Right. I did not mention it but one thing that is being considered would be the use of solenoid focusing magnets here which would avoid the asymmetric focusing of the quadrupoles. By going through a circular symmetric variable iris we should be able to maintain a circular profile going into the RFQ.

West: I'm not sure I understand that.

Muller, GSI: How did you measure or estimate the degree of space charge compensation?

Schneider: That was done somewhat indirectly, using a code that has been developed and is in use at Los Alamos - one of them is a multiple species transport that Dale Armstrong has been working with. The estimate there, and we have verification of it from some other results, says that with 97% space charge neutralization, we would see the approximate beam profile that we do see. So it's indirect inference.

Curtis, FNAL: I suppose the collimator you are talking about using is for tune-up purposes only, or do you plan to continue collimating the beam when you are running full current deuterons? In which case, you will have to give some thought to the neutron yield.

Schneider: We have given some thought to that - we do have the capability of running - this entire thing will sit inside a vault behind thick concrete walls. We don't think the activation problem would be serious. It would be enough that personnel could not be inside but normally if we can run the entire accelerator at full beam current, this thing could be wide open.

Wadlinger, LASL: Why use an oil diffusion pump to pump the column?

Schneider: We have been asked that many times. I think the answer is that we have used it for some length of time and have had absolutely no problem with it. The alternative would be something like a turbo-molecular pump, which has its own problems - it is a mechanical device. This one has a lot of fast acting valves to protect it - the polythenol-ether fluid has not caused any contamination in

about 2½ years of operation. It is heavily trapped - we have a freon refrigerated baffle above it, as well as the cold traps right in the trop of the pump and we get tremendous pumping by doing it. I did not mention it, but part of the motivation for that was to absolutely minimize the pressure in the high voltage region, which of course minimizes the production of x-rays.

Barton, BNL: What assumptions have been made about space charge effects in your LEBT design?

Schneider: We assumed that the beam is mostly space charge neutralized. Maybe I don't follow your question.

Barton: Well, I asked it because I understand from your vacuum system specifications you have quite different vacuum and could expect different behavior from several aspects as you go through that line.

Schneider: Oh, because the vacuum profile does change?

Barton: Not only that - just electron effects in varying magnitude.

Schneider: It is possible we'd have difficulties although we have a very substantial safety margin in that. I think there is 90% or less neutralization, the beam would still be able to be transported easily.