

THE rf MODULATOR DESIGN AND PHASE AMPLITUDE CONTROL FOR
A HIGH-POWER FREE-ELECTRON-LASER LINAC*

R. F. Hoerberling and P. J. Tallerico AT-5 (MS 827)
Los Alamos National Laboratory, Los Alamos, New Mexico 87545

SUMMARY

The continued interest for building tunable lasers using an electron accelerator as the source of primary energy has resulted in the design of a new accelerator.¹ Earlier work by other members of the Los Alamos team has demonstrated that this design does work in an amplifier mode.² The accelerator is to be upgraded for use in an oscillator experiment and the new rf power amplifier system must meet some of the very stringent demands for power and stability placed on the electron beam for the free-electron laser (FEL) interaction to be observed. These demands are particularly stringent because the electron beam energy ultimately will be circulated back through the accelerator so that the electron beam energy not used in the FEL interaction is not wasted. These considerations have to some measure been incorporated into the design of the second FEL system at Los Alamos and are discussed in this paper.

INTRODUCTION

The primary needs of this accelerator are to provide the "make-up" power that must be replaced during the intrapulse interval to get the power back to the operating level required for satisfactory FEL interaction. The basic schematic for one of the possible accelerator configurations is shown in Fig. 1. System requirements call for a 100- μ s pulse length and more than 7 MW peak power for some of the experiments. These are already severe requirements that exceed rated performance of existing klystrons. Additional performance criteria arise from the unique demands caused by the FEL interaction experiment. These demands relate particularly to the stability requirements of the phase and amplitude controls needed for the experiment. These stability requirements can be categorized as long-term stability (days), short-term stability (seconds), and phase stability (submicro-second). These requirements must be met to have synchronization in the FEL interaction region. The output electron-beam energy must be held constant from pulse to pulse to have the correct electron momentum for resonance (and energy extraction) with the laser field. The condition for this resonance is given by the expression (in mks units)³

$$\gamma_r^2 = \frac{\lambda_W}{2\lambda_L} \left(1 + \frac{e^2 B^2 \lambda_W^2}{4\pi^2 m^2 c^2} \right), \quad (1)$$

where λ_W is the wiggler period, λ_L the laser

*Work performed under the auspices of the US Department of Energy with the support of the Air Force Office of Scientific Research, the Defense Advanced Research Projects Agency, and the Naval Air Systems Command.

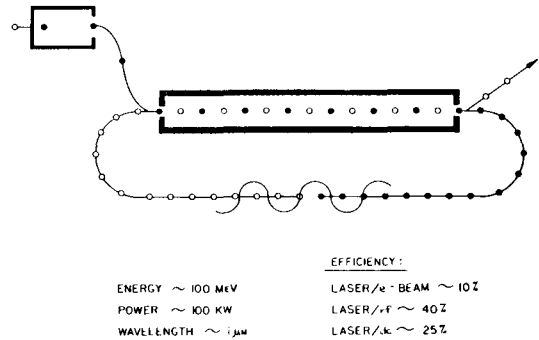

Fig. 1. Schematic diagram of the rf racetrack energy recovery system. To decelerate the electrons emerging from the free-electron laser, they are reinserted into the accelerator 180° out of phase from the accelerating electrons, so that the rf fields have reversed. High power and high overall efficiency can be achieved this way (Fig. 4 from ref. 3).

wavelength, e the electron charge, B the rms magnetic induction of the wiggler, m the electron rest mass, and c the velocity of light. The term in parentheses represents a correction (generally of the order of unity) for the change in path length caused by the electron excursions in large magnetic fields. The allowable detuning of the laser from the resonance condition, the gain bandwidth of the FEL amplifier, is given by the approximate expression

$$\frac{\Delta\lambda}{\lambda} \sim \frac{1}{2N}, \quad (2)$$

where N is the number of magnet periods along the length of the wiggler.

The requirement on rf amplitude stability then becomes related to the frequency-gain characteristic of the particular wiggler used in the experiment. For example, the initial system has effectively 20 magnetic periods, so that from Eq. (2) the allowable frequency change is approximately

$$\frac{\Delta f}{f} = -\frac{\Delta\lambda}{\lambda} = -\frac{1}{2n} = -2\frac{1}{2}\%$$

so that

$$\frac{\Delta\gamma_r}{\gamma_r} = -\frac{1}{2} \frac{\Delta\lambda}{\lambda} = 1\frac{1}{4}\%$$

Long-term and short-term frequency stability of the rf is important in the experiment to avoid constant retuning of the optical cavity length. The frequency changes of the accelerator are

caused by thermal drifts and by aging. The optical cavity length is to be held to five parts in 10^3 . These changes can result in a phase shift of 8.2×10^{-2} radians/pass that accumulates during the 100- μ s accelerator pulse length. To maintain less change in the accelerator, then

$$\frac{\Delta f}{f} < 2.0 \times 10^{-4}$$

Retuning the accelerator center frequency may be a convenient way to optimize (over small ranges) the optical cavity.

The laser cavity also is a resonant structure that sets requirements on the phase stability during shorter intervals. To allow the laser resonance to adjust, the phase of the electron-beam bunches entering the laser cavity should not change too rapidly. The response time is set by the laser cavity Q, which is greater than 50. During this interval, the frequency of the accelerator should not change enough that the photon packet and the electron bunch fail to overlap within $1-1/2^\circ$ of phase, so that

$$\frac{\Delta f}{f} < 5.5 \times 10^{-6}$$

in a period of a few microseconds.

Another phase-stability requirement in a cyclic device is to have the electrons re-enter the accelerator at the proper phase (180° out, with respect to acceleration) to give up their energy to the accelerating structure. This requirement is also dependent on the accelerator emittance and longitudinal velocity spread, the beam bending magnets, and the amount of beam fluctuation introduced by the FEL interaction region. For this FEL with 100-MeV electrons, a 60-m-path length, and an allowable phase shift of about 5° , the allowable single-pass frequency shift is

$$\frac{\Delta f}{f} = 5.3 \times 10^{-5}$$

in a period of 200 ns.

Another constraint on the phase stability is that the electron micropulse packets must be properly spaced within the FEL interaction region. The typical figure for FEL design is that the intrapulse jitter be such that the phasing between the optical pulse and the electron pulse be synchronized within ten per cent of their width. For the present case, this means that the phase shift is limited to 2° , so that

$$\frac{\Delta f}{f} < 5.5 \times 10^{-4}$$

in a period of 50 ns.

Other rf Constraints

Aside from the normal personnel and equipment safety requirements, other constraints on the rf system include

1. operation of one klystron to drive three separate accelerating rf cavities with independent phasing and amplitude control for each; and

2. the rf amplifiers need to be continuously variable in output power and pulse length to allow different experimental configurations.

The rf Modulator Design

The basic electrical schematic for the modulator has been previously described⁴ and is shown in Fig. 2. The system includes single-point grounding at the modulator tank and substantial rf shielding around the capacitor bank. The large capacitor tank (8.75 μ F) was needed to minimize voltage droop during the pulse. This system, at full power, results in 1500-V droop during the pulse. This results in a phase shift of the rf pulse caused by the klystron with a beam path length, ℓ , of

$$\Delta\phi = \omega\Delta\tau = \frac{\omega\ell}{c} \left(\frac{1}{\beta_f} - \frac{1}{\beta_i} \right) = 0.22 \text{ radian, or about } 12^\circ,$$

so that $\Delta f/f = 1.7 \times 10^{-6}$ in 100 μ s.

Also, the long pulse length puts additional stress on the switch tube: fortunately, the standard LAMPF triode⁵ proved to be satisfactory for this application.

The rf Power Distribution System

The requirement to feed three tanks from one klystron actually was beneficial. This allowed for much less complex rf phase control because each tank was locked to a single driver, and slow phase control could be employed between the tanks. The rf distribution system shown in Fig. 3 has been assembled and has an insertion loss of less than a decibel (without the isolator). A similar distribution system has been demonstrated at X-band.⁶ The use of low phase versus temperature cable and some thermal control was necessitated by the long cable runs.

The rf Phase Control

The requirements for phase stability described above resulted in design of rf controls at the state-of-the-art. The rf source chosen for this system has long-term stability of three parts per

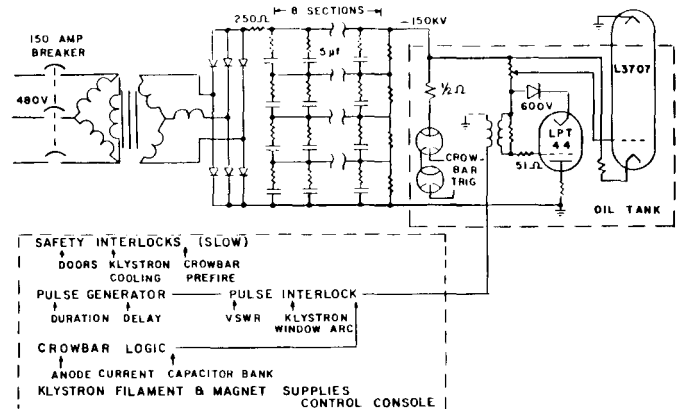

Fig. 2. Electrical schematic of rf modulator.

million, and minimized phase noise; these are accomplished by choosing the crystal frequency to be as high as possible and using low noise electronics. The phase spectral density (frequency domain) and Allan Variance (time domain) for two oscillators are now being characterized. In evaluating the performance of the rf source, as compared to the system requirements, the effect of the acceleration cavity also must be considered. This is a side-coupled, standing-wave structure with an anticipated loaded Q of 6500. The effective Q is anticipated to be very similar because of little rf overdrive available. This means that the cavity will not allow for frequency changes in time scale less than

$$\Delta t \sim \frac{1}{\Delta f} \sim \frac{Q}{f} = \frac{6.5 \times 10^3}{1.3 \times 10^9} = 5 \mu s$$

This greatly simplifies the source design because both the rf source and the accelerating cavity are narrow band pass, high Q elements that do not allow fast frequency changes. Power provided to the tanks at the wrong frequency is dissipated in the isolators, circulators, and external loads designed into the system as shown in Fig. 3.

The rf Amplitude Control

The need for the very long pulse length in this experiment requires active amplitude control. The droop in the capacitor bank voltage results in a corresponding droop in the accelerating fields. This is accomplished with absorptive active attenuators that respond to the rf power droop during the pulse. The complete rf drive system is shown in Fig. 4.

Acknowledgments

It is with great pleasure that the authors acknowledge the help of Charles Brau, Robert Jameson, and Tom Boyd in translating the experimental program requirements into terms useful for rf design. The helpful conversations with Charles Brau, Robert Jameson, and William Stein have certainly made this a more useful design. The assistance of Ralph Garcia and Dave Keffler in making some of the rf tests and measurements is gratefully

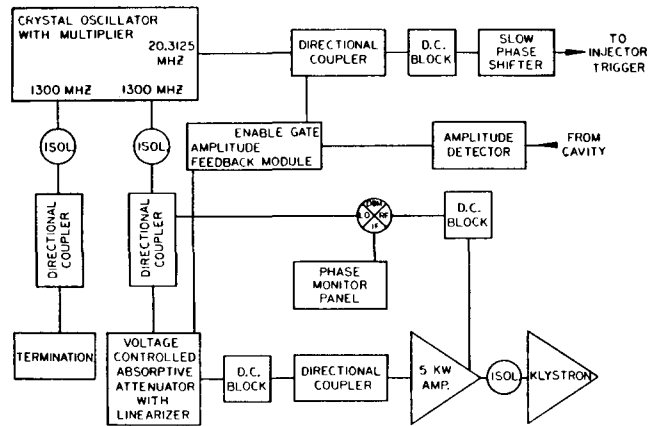

Fig. 4. Frequency generator for the accelerator.

acknowledged, as is the earlier rf amplitude and phase control efforts of the designers of the Los Alamos Meson Facility.

References

1. W. E. Stein, C. A. Brau, B. E. Newnam, R. W. Warren, and J. G. Winston, "LASL Free-Electron Laser Experiments," Proc. 6th Conf. on Applications of Accelerators in Research and Industry, Denton, Texas, November 3-5, 1980, IEEE Trans. Nucl. Sci. 28, p. 1522 (1981).
2. W. E. Stein, C. A. Brau, B. E. Newnam, R. W. Warren, and J. G. Winston, "LASL Free-Electron Laser Experiment Results," 1981 Linear Accelerator Conf., Santa Fe, New Mexico, October 19-23, 1981, to be issued.
3. C. A. Brau, "Free-Electron Lasers Overview: Fundamentals and Application," Los Alamos National Laboratory report LA-UR-80-185 (June 1980).
4. R. F. Hoerberling and P. J. Tallerico, "Long-Pulse Applications of Pulse-Forming Lines for High-Power Linac Applications," Proc. 1981 Particle Accelerator Conf., Washington, DC, March 1981, IEEE Nucl. Sci. 28, p. 2958 (1981).
5. P. J. Tallerico, R. L. Cady, and J. D. Doss, "Design and Performance of the LAMPF 1 1/4-MW Klystron Modulator," IEEE Conf. Record 11th Modulator Symp., New York, New York, September 18-19, 1973, p. 55 (1973).
6. W. L. Teeter and K. R. Bushore, IRE Transactions on Microwave Theory and Techniques, Vol. MTTS, p. 227 (1957).

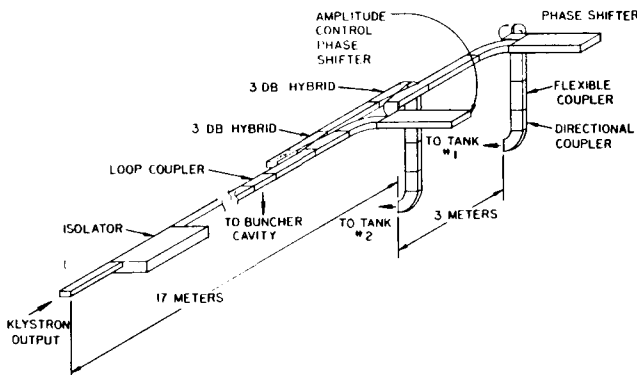

Fig. 3. Distribution system for three cavities using a single klystron.