

A HEAVY ION INJECTOR FOR THE CERN LINAC 1

N. Angert, J. Klabunde, B. Langenbeck, K. Leible, P. Spädtke,  
J. Struckmeier and B.H. Wolf  
GSI, 6100 Darmstadt, Fed. Rep. of Germany

S. Abbott, D. Brodzik, R. Gough, D. Howard, H. Lancaster and J. Staples  
LBL, Berkeley, California 94720, USA

H. Haseroth, C. Hill, P. Tatu and M. Weiss  
CERN, 1211 Geneva, Switzerland

R. Geller  
CENG, 38041 Grenoble, France

Summary

An injector system has been designed to provide a fully stripped oxygen beam for acceleration in the CERN PS complex. An ECR source will provide an  $O^{6+}$  beam to a heavy ion RFQ accelerator. The beam from the RFQ will be further accelerated by the CERN Linac 1 ("Old Linac") in the  $2\beta\lambda$ -mode to an energy of 12.5 MeV/u at which point it will be fully stripped for subsequent acceleration in the CERN synchrotrons. The specifications of the new equipment and modifications to the existing linear accelerator are described.

Introduction

A GSI-LBL-Heidelberg-Warsaw-collaboration proposed an experiment for the study of relativistic nucleus-nucleus reactions induced by  $^{16}O$ -beams at the CERN PS in 1982<sup>1</sup>. After study of its implications to the PS machines<sup>2</sup> this proposal was accepted in 1983. For the generation and acceleration of the heavy ions a collaboration was established between CENG, CERN, GSI and LBL. Fig. 1 shows a general view of the accelerators involved.

Selection Criteria for Ion Species

For the proposed experiment the projectile nucleus should be as heavy as possible. However, as the CERN PS complex was not designed for this purpose, the choice of ion species was restricted by the given boundary conditions, as are accelerating field levels in the linac and lower current limits for controlling and monitoring the existing ring accelerators.

The CERN Linac 1, which could be used for these beams, usually accelerates protons from 520 keV to 50 MeV. So far only deuterons and  $\alpha$ -particles have been accelerated in the  $2\beta\lambda$ -mode from 130 keV/u to 12.5 MeV/u. As in this acceleration mode the particles have only half of the design velocity, the transit time factors are strongly reduced. This is especially true at the beginning of tank 1. In the first gap, for example, the transit time factor is reduced by 2.9. Therefore, for synchronous acceleration the field level for deuteron acceleration has to be increased by around 45 % in the first gap and about 11 % in the middle of tank 1 as compared to the proton field strength. In the last gap the ideal field level is 8 % below the proton rate. Without considering the transit time factor one would calculate half the proton field level for deuterons. It is very difficult to fulfill this tilt requirement in the first tank. On the other hand, if the theoretical field distribution cannot be attained, this results in a reduction of the longitudinal acceptance and an increase of the injection energy to about 140 keV/u. This determines the output energy of the RFQ. Fine adjustment of the Alvarez injection energy can be made with a matching cavity behind the RFQ.

Sparking limits in the first tank of Linac 1 result in a minimum charge to mass ratio of 0.375 for ions which could be accelerated with reasonable longitudinal acceptance. This means a 33 % higher accelerating field level than for deuterons.

Possible candidates for heavy ions to be accelerated in the CERN PS complex were therefore  $^{16}O^{6+}$  ( $q/A = 0.375$ ),  $^{16}O^{7+}$  ( $q/A = 0.437$ ) or  $^{20}Ne^{8+}$  ( $q/A = 0.4$ ). The beam diagnostics for controlling the synchrotron accelerators requires a minimum peak current of about 10  $\mu A$ . Taking into account all matching and transmission losses this will require about 80 to 100  $\mu A$  from the ion source. The only source which could provide this current is an Electron Cyclotron Resonance (ECR)<sup>3</sup> source for  $O^{6+}$ .

ECR Source

In routine operation, the ECR source, Fig. 2, delivers in a quasi continuous regime a plateau value of 15  $\mu A$   $O^{6+}$ . For the application at the synchrotron useful beam is only needed inside a pulse duration of about 150  $\mu s$  at a repetition rate of 1 Hz. In this mode the plateau current can be increased by a factor of six by pulsing of the discharge, by flexible adjustment of the microwave power and the gas pressure. In 1983, in a preliminary approach, pulsed  $O^{6+}$  currents of 50  $\mu A$  with 100 ms duration have been obtained in a very reproducible manner. This was measured after magnetic selection

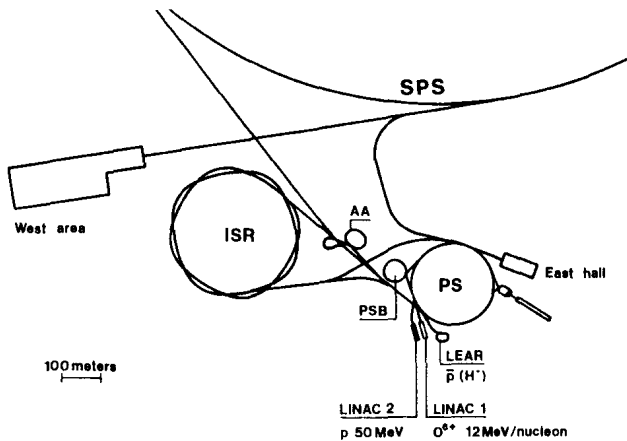

Fig. 1: Layout of the accelerator complex for the relativistic  $^{16}O$ -beam

The  $^{16}O^{6+}$  ions are generated and preaccelerated in an injector, which is described later and are accelerated in the Linac 1 ("Old Linac") to 12.5 MeV/u. Then they will be fully stripped for further acceleration in the booster rings, the PS and finally the SPS. The latter is primarily used for the transport of the beam to the west area, where the experiments will be set up, but it can also be used for further acceleration.

\*The LBL portion of this work was supported by the Director, Office of Energy Research, Office of High Energy and Nuclear Physics, Nuclear Science Div., U.S. Dept. of Energy under Contract No. DE-AC03-76SF00098.

and at a distance of 2 m from the extraction aperture at 15 kV extraction voltage. In spring 1984 with improved extraction and beam transport optics, 80  $\mu$ A of  $O^{6+}$  have been measured at a distance of about 1 m, after 110° analysis. 90 % of this current is within an emittance (at 5.6 keV/u) of  $50 \pi$  mm mrad and 75 % within  $30 \pi$  mm mrad respectively (Fig. 3a,b)<sup>4</sup>. In addition, this source type should offer a long lifetime and an easy handling.

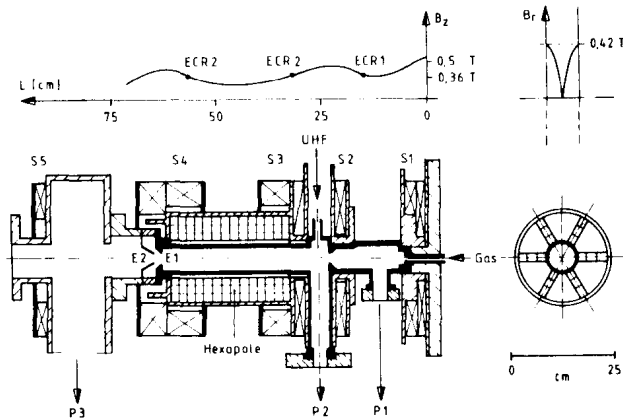

Fig. 2: ECR-ion source MINIMAFIOS

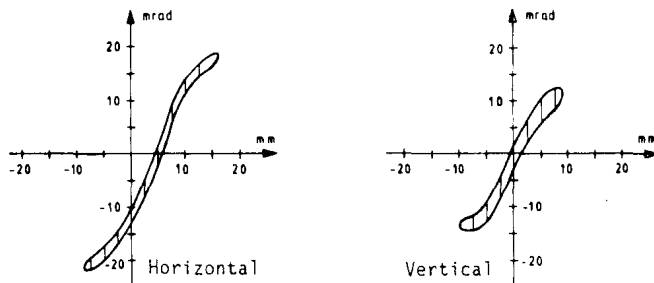

Fig. 3: Emittance of ECR-source for  $O^{6+}$   
 $\epsilon_{75\%} = 30 \pi$  mm mrad

Low Energy Beam Transport

The low energy beam transport between the ECR source and the RFQ preaccelerator (Fig. 4) was designed to have at least the same acceptance as the RFQ. That means a normalized value of  $0.9 \pi$  mm mrad or  $290 \pi$  mm mrad at 5.6 keV/u for the  $O^{6+}$  beam extracted from the ECR source with an extraction voltage of 15 kV. The oxygen ion beam is matched by a first solenoid to a double focusing 90° bending magnet. After the magnet the selected  $O^{6+}$  beam is matched by a quadrupole triplet and a second solenoid to the RFQ. The RFQ structure requires a strongly convergent round beam (0.15 rad). The entire beam transport optics is designed to have minimum aberrations and beam losses. Several beam diag-

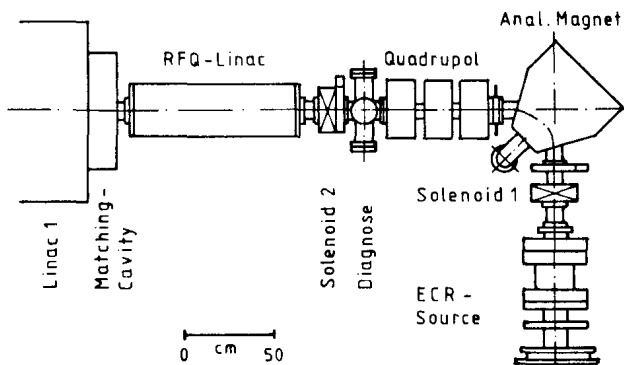

Fig. 4: Oxygen injector for CERN Linac 1

nostic elements (Faraday cup, beam transformer, profile monitor and segmented probe at the RFQ entrance) will facilitate the proper adjustment of the ion beam to the RFQ accelerator.

RFQ Accelerator

The ECR source will be operated at a nominal potential of 15 kV, providing a  $^{16}O^{6+}$  beam of 5.6 keV/u. The RFQ linac will accelerate this beam to 139.5 keV/u, the energy required for optimal injection into Linac 1 in the  $2 \beta\lambda$ -mode. In addition, the RFQ will provide a normalized transverse acceptance of  $0.9 \pi$  mm mrad, and will bunch the beam into a longitudinal phase space area of less than 0.4 MeV/u degree. The transverse acceptance requirement is set by the brightness characteristics of the ECR source. The output longitudinal phase space specification, together with the operating frequency of 202.56 MHz, are driven by the requirements of Linac 1.

High-frequency, heavy-ion RFQ linac designs tend to have a small aperture, a small acceptance, and a small minimum longitudinal vanetip radius,  $\rho_{11}$ <sup>5</sup>. Attempts to raise the acceptance tend to reduce  $\rho_{11}$  to the point where the tool used to machine the vanetips becomes impractically small. For this application, a design has been found where the normalized transverse acceptance is maintained at a conservative level of  $0.9 \pi$  mm mrad, while keeping  $\rho_{11} > 11$  mm. This was achieved by using a large value of the focusing parameter B of 7, and a relatively low value of the maximum surface field of 25.9 MV/m, or about 1.76 times the Kilpatrick criterion<sup>6</sup>.

This value of the focusing parameter, unusually high compared with existing heavy ion RFQ's, causes large divergences in the beam inside and at the exit of the accelerator. To ease the problem of matching into the following linac, an exit radial matching section is added, in which the value of B is reduced from 7 to 4, or from 44 to 24 degrees phase advance per period, over the last betatron wavelength. This technique preserves the high value of B in the first part of the structure, which is needed to establish the transverse acceptance conditions, but reduces the transverse focusing at the exit end of the structure, to control the divergence of the emerging beam. The total length of the RFQ is 858 mm of which only the last 188 mm is used for the exit radial matcher. As the value of the mean bore radius  $R_0$  varies in the exit matcher, so does the cutoff frequency of the structure. This is compensated by local tuners.

The mechanical design will be similar to the heavy ion RFQ developed at LBL for use at the Bevatron<sup>7</sup>. This is a four vane, loop-driven structure with each vane mounted on supports that penetrate the cavity wall to give a precise and reproducible positioning. The vanes and cavity will be of copper plated, low carbon steel. Canted helical springs will be used to establish an rf contact between the base of the vanes and the cavity. A pumping speed requirement on the cavity on the order of 500 litres/second is anticipated to maintain a pressure in the  $10^{-7}$  Torr pressure range.

Since the RFQ is short, about 0.57 free space wavelengths, alignment and tuning of the structure are not expected to be a major difficulty. The opposing vanes will be strapped together with vane coupling rings (VCR's)<sup>8</sup>. to ensure azimuthal field balance between quadrants and to eliminate the troublesome dipole modes. The tuning of the cavity is then reduced to the removal of any axial tilts, which is accomplished by proper choice of end geometry. With this arrangement, only one drive loop and one fine tuner (for dynamic frequency adjustment) is needed. It is currently planned to incorporate as many as three sets of VCR's. The coarse frequency adjustment of the cavity will be set by two tuning bars attached to each of the four vanes near their base. These bars will be tapered to compensate the 6 MHz change in cutoff frequency in the exit radial matching section.

The vane-vane voltage required for operation with  $^{16}\text{O}^{6+}$  is 35.6 kV. The theoretical Q value is 10900 with ideal copper walls and no joint losses. Experience has shown that the actual operating Q will be about one-half of this, or about 5500, due to the many RF joints and to imperfections in the copper plating along with other factors. With this value of Q, the peak power demand will be about 21 kW. The average power dissipation at a duty factor of less than 0.001 will be just a few watts.

The basic parameters of the RFQ are summarized below:

Design ion	$^{16}\text{O}^{6+}$
Theoretical transmission	95 %
Frequency	202,56 MHz
$T_{in}$	5.625 keV/u
$T_{out}$	139.5 keV/u
Length	858 mm
$R_0$	2.10 mm
No. of cells	169
$P_{il}$	12.5 mm
Vane-vane voltage	35.6 kV
Peak rf power	21 kW (at Q = 5500)
Transverse acceptance	$\pi \epsilon_n(x) = 0.9 \pi \text{ mm-mrad}$ $\pi \epsilon_n(y) = 0.9 \pi \text{ mm-mrad}$
Output phase spread	$\pm 23^\circ$
Output energy spread	$\pm 4.3 \text{ keV/u}$

The construction, tuning and low power testing of the RFQ will be carried out at LBL. To match the beam to the Linac 1 a rebuncher cavity will be located between the RFQ and Linac 1, which has a similar design to the present one for protons.<sup>9</sup> Also the rf generator system can be used for both rebuncher cavities.

Linac Modifications

New rf amplifiers are in preparation to provide the 33 % higher fields needed for  $\text{O}^{6+}$ . Cryopumping will be used to aid the attainment of this level in tank 1 and to reduce recombination losses of the  $\text{O}^{6+}$  beam. Beam measuring equipment will be upgraded to cope with the low intensity ( $10^{-4}$  of proton intensity). Beam transformer resolution of better than 1 microamp is being thought. Secondary emission monitors are in preparation for emittance and profile measurements. The high energy beam transport will be converted to pulsed operation (ions from Linac 1, protons from Linac 2).

Charge Exchange Losses

An important point to be considered in the acceleration of highly charged ions is the loss of particles due to charge exchange processes in the residual gas.  $\text{O}^{6+}$  has a rather large cross section  $\sigma_c$  for the capture of electrons from the residual gas molecules in the low energy beam transport and accelerating structures. For gases as  $\text{N}_2$ ,  $\text{O}_2$ ,  $\text{CO}_2$ ,  $\text{CH}_4$  the  $\text{O}^{6+}$  single electron capture cross section is about  $10^{-14} \text{ cm}^2$  up to an energy of about 100 keV/u.<sup>10</sup> Then it is steeply decreasing ( $\sim \beta^{-4}$ )<sup>11</sup>. The ions extracted from the ECR-source with 15 kV will be accelerated in the RFQ up to 139 keV/u. The distance between the source and the first accelerating gap of Linac 1 is about 3.5 m. Assuming a residual gas pressure of  $4 \cdot 10^{-7}$  Torr, a total loss of the  $\text{O}^{6+}$  beam by charge exchange of about 5 % is calculated.

Electron loss cross sections can be neglected in this velocity range. Tank 1 of Linac 1 accelerates to 2.5 MeV/u in the  $2\beta\lambda$ -mode, so that only the first meter plays a role for the capture cross sections. Assuming a pressure of  $4 \cdot 10^{-6}$  Torr and an averaged capture cross section of  $3 \cdot 10^{-15} \text{ cm}^2$ , a loss of 4 % is expected in the initial accelerating stages of tank 1. For the rest of tank 1  $\sigma_c$  is smaller than  $10^{-16} \text{ cm}^2$ , therefore, the beam loss should be only about 1 %.

The cross sections for the loss of an electron become dominant for the higher velocities, but they are smaller than  $10^{-17} \text{ cm}^2$  in the whole energy range up to 12.5 MeV/u.<sup>12</sup> Therefore the total loss at higher energies would be below 1 %, so that the total transmission losses through the injector and the Linac caused by charge exchange processes would be about 10 % under the assumption of  $4 \cdot 10^{-7}$  Torr in the low energy section and  $4 \cdot 10^{-6}$  Torr in the Linac tanks. However, in practice the residual gas pressures should be 3 to 4 times lower.

Time Scale

The low energy beam transport system will be installed at GSI in spring 1985. After test runs at Grenoble the ECR source will be delivered to GSI in May 1985 and then be tested with the beam transport system. The RFQ will be moved to GSI by middle of 1985 afterwards the whole injector with RFQ will be tested and optimized at GSI until November 1985. If all the specifications are fulfilled the apparatus will be transferred to CERN at the end of 1985 and be installed at Linac 1 end of 1985. The first  $^{16}\text{O}$ -run is planned very early after installation of the equipment and first experiments are planned in spring 1986.

References

<sup>1</sup>Stock et al.: Study of Relativistic Nucleus-Nucleus Reactions Induced by  $^{16}\text{O}$  Beams of 9-13 GeV per Nucleon at the CERN PS, Proc. of the Bielefeld Workshop on Quark Matter Formation and Heavy Ion Collisions, May 1982, p. 557, Edit. M. Jacob and H. Satz.  
<sup>2</sup>H. Haseroth, Light Ions at CERN, *ibid.*  
<sup>3</sup>R. Geller and B. Jacquot, Nucl. Instr. Meth. **202**, 399 (1982).  
<sup>4</sup>P. Spädtke, K. Leible and B.H. Wolf, GSI-Int.-Notice, GSI-Darmstadt  
<sup>5</sup>J. Staples, "RFQ Development at LBL", Heavy Ion Fusion Workshop, Tokyo, Japan (Jan. 1984).  
<sup>6</sup>W.D. Kilpatrick, "Criterion for Vacuum Sparking Designed to Include Both RF and DC", UCRL-2321 (Sept. 1953).  
<sup>7</sup>J. Staples, et al., "Initial Operation of the LBL Heavy Ion RFQ", Conference on High-Energy Accelerator, Batavia, IL, USA, August 1983.  
<sup>8</sup>H. Lancaster, et al., "Vane Coupling Rings Simplify Tuning of the LBL RFQ Accelerator", Conference on High-Energy Accelerator, Batavia, IL, USA, August 1983.  
<sup>9</sup>E. Boltezar et al., These proceedings.  
<sup>10</sup>A. Müller and E. Salzborn, Phys. Lett. **62A**, 391 (1977).  
<sup>11</sup>E. Salzborn and A. Müller, Proc. XIth Int. Conf. Phys. of Electronic and Atomic Collisions, p. 407, Kyoto 1979.  
<sup>12</sup>I.S. Dmitriev et al., Sov. Phys. JETP **15** (1), 11 (1962).