

BEAMSTRAHLUNG MONITOR FOR SLC FINAL FOCUS USING VISIBLE WAVELENGTHS*

GIOVANNI BONVICINI

University of Michigan, Ann Arbor, Michigan 48109

JIM FERRIE and CLIVE FIELD

Stanford Linear Accelerator Center, Stanford, California 94305

ADOLF MINTEN

CERN, Geneva 23, Switzerland

1. Introduction

In an accompanying paper¹ the production and detection of small angle beamstrahlung at energies $\gtrsim 30$ MeV is discussed. The theory has been extended to emission at wide angles and wavelengths near the visible². The radiation intensity is well approximated by

$$I(\theta, \omega) = \frac{3}{\sqrt{\pi}} \frac{\sigma_z W}{\pi c \gamma^4 \theta^3} \exp\left(\frac{-\sigma_z^2 \theta^4 \omega^2}{16c^2}\right),$$

where θ and ω are the photon angle and frequency, γ the Lorentz factor, σ_z the longitudinal beam spread, and W the total energy emitted. Also

$$W = 0.22 r^2 \gamma^2 m c^2 \frac{N_1 N_2^2}{\sigma_x \sigma_y \sigma_z} \propto L N_2 / \sigma_z$$

where r is the classical radius and m the mass of the electron, N_1 the bunch population of the radiating beam, N_2 that of the other beam, σ_x, σ_y the bunch widths in x and y axes, and L the luminosity for one crossing. Thus I is only dependent on

$$\frac{N_2 L}{\beta^3} \exp\left(-\sigma_z^2 \theta^4 \omega^2 / 16c^2\right).$$

In the case of visible light at about 7.5 mrad, the exponential factor is about 0.95, and is insensitive to small changes in its parameters. So, at fixed angle the visible beamstrahlung signal is closely related to the luminosity for head on collisions of the beams. As usual for beamstrahlung, the flux actually peaks for beam-beam offsets of 1 to 2 R.M.S. widths³ (except in the case of strong disruption), and thereafter falls off inversely with beam-beam separation.

The expected size of the signals at SLC is limited by severe geometrical constraints. The possible access position is 43 cm beyond a synchrotron radiation mask. It is necessary to keep the inner edge of the device at a greater radius than that of the mask to preserve the masking efficiency. The mask shadows the interaction point emission at the outer radius of the beamstrahlung monitor, and leaves only a 0.5 mrad aperture at about 7.5 mrad.

A schematic drawing of one channel of such a device is shown in the figure. Light from a 2 mm wide plane mirror (acting as a periscope) is directed, perpendicular to the beam axis, through a narrow channel in a spool piece in the vacuum pipe. The light leaves the vacuum through a sapphire window. It is focussed by a lens on to a an iris of minimum size 1 mm by 0.2 mm. (Diffraction effects increase the image size in one axis). Beyond the iris the light is reflected into a small photomultiplier tube. Initial alignment of the optics makes use of a light source at the interaction point. The iris is moved to maximize the signal.

*Work supported by the Department of Energy, contract DE-AC03-76SF00515.

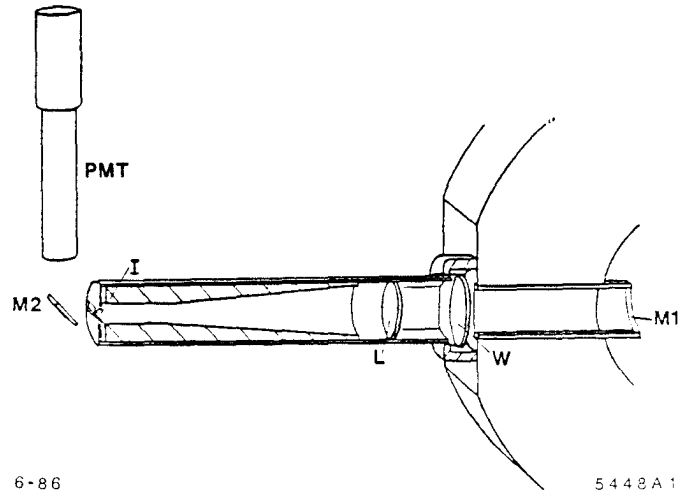

Fig. 1. Beamstrahlung periscope: $M1$ is the primary mirror, W the vacuum window, L the lens, I the iris, and $M2$ a 45° mirror. The surrounding radiation shielding is not shown.

The iris is intended to reduce the largely unknown visible light backgrounds from scattered synchrotron radiation in the beam pipe. However, each primary mirror will be exposed to about 10^6 gamma rays, of critical energy ~ 550 keV, every pulse. With shielding installed outside the vacuum, this is not expected to lead to a background. In addition, the region may be susceptible to occasional showers from multi-GeV electrons, and since visible light backgrounds are not known, the background has presently to be considered an experimental topic.

An analysis of the performance of the device shows that the expected output from the four photomultipliers on either side of the interaction point—in terms of photoelectrons—is:

$$150 \text{ photoelectrons at } 5 \times 10^{10} e^\pm \text{ per pulse and luminosity } 10^{29} \text{ at } 120 \text{ Hz.}$$

For this and higher luminosities the device promises to be a useful monitor of beam size variations. It is almost totally different from the high energy beamstrahlung technique, and so provides a measure of independence to the interaction point diagnostics.

References

1. G. Bonvicini *et al.*, "Beamstrahlung Monitor for SLC Final Focus Using Gamma Ray Energies," contribution to this conference.
2. R. Coisson, *Phys. Rev.*, **A20**, 524 (1979).
3. M. Bassetti *et al.*, *IEEE Trans. Nucl. Science NS* **30**, 2182 (1983).