

"SMILE" A NEW VERSION FOR THE RADLAC II LINEAR ACCELERATOR\*

M. G. Mazarakis, J. W. Poukey, S. L. Shope, C. A. Frost  
 P. J. Pankuch, B. N. Turman, J. J. Ramirez, K. R. Prestwich

Sandia National Laboratory  
 P. O. Box 5800  
 Albuquerque, NM 87185

**Abstract**

We present here the SMILE modification of the RADLAC II accelerator which enabled us to produce high quality 12-14 MV, 100 kA beams. The modification of replacing the 40-kA 4-MV beam injector, magnetic vacuum transport and accelerating gaps by a long cathode shank which adds up the voltages of the 8 pulse forming lines. The beam now is produced at the end of the accelerator and is free of all the possible instabilities associated with accelerating gaps and magnetic vacuum transport. Annular beams with  $\beta_{\parallel} \leq 0.1$  and radius  $r_b \leq 2$  cm are routinely obtained and extracted from a small magnetically immersed foilless electron diode. Results of the experimental evaluation are presented and compared with design parameters and numerical simulation predictions.

**Introduction**

Following the successful operation of the four-feed, 8-MV magnetically insulated transmission line injector<sup>(1)</sup>, an eight-feed Self Magnetically Insulated Transmission Line ("SMILE") for the RADLAC-II accelerator was designed and installed. The design is similar to that of the HERMES III<sup>(2)</sup> and HELIA<sup>(3)</sup> accelerators and was done using the Creedon formalism<sup>(4)</sup>. The basic idea is to replace all accelerating gaps by an MITL voltage adder which runs along the entire length of the device. The design was validated with the PIC MAGIC<sup>(5)</sup> code.

In the following sections we present the SMILE design, numerical simulations validating the design, and experimental results.

**SMILE Design**

The SMILE design is based on a pulse forming line-fed self-magnetically insulated transmission line (MITL) system which performs the series addition of voltage pulses from 8 source modules (feeds). The cathode geometry is shown in Figure 1, and it is preferred over a continuous taper for the following reasons: it is easier and cheaper to manufacture, the constant radius segments provide constant vacuum impedance along each MITL segment, and the impedance increases gradually at each successive voltage feed with a rate of increase which follows the voltage axial gradient along the feed. The latter assures constant current flow over the entire length of SMILE.

The vacuum impedance of each section *i* of SMILE depends only on the dimensions of Figure 1 and can be easily calculated from the following expression

$$Z_i = 60 \ln (R/r_i) [\Omega]; r_i = 1, 2, \dots, 8 \quad (1)$$

where *R* = 21.5 cm is the anode inner radius and *r<sub>i</sub>* is the radius of the *i*-th cathode segment. The selection of the radius *r<sub>i</sub>* of each cylindrical section was done in a fashion to provide constant operating load impedance for all the pulse forming line feeds of RADLAC II. Some deviations were allowed at the beginning of the cathode shank where self-magnetic insulation is not that critical and also at the high voltage end for mechanical and construction reasons.

The point design is for 110 kA and assumes equal 2-MV voltages at each insulating stack feed. An MITL operating with conditions similar to SMILE is a "balanced" one. Because of the relatively short voltage pulse (40 ns fwhm) of each feed, the current flow is self limited and to a large extent independent of the diode impedance conditions. However in our design we stayed as close as possible to the constant current conditions all the way to the end of the cathode tip. At first we selected the radius of the cathode tip. The outside wall radius of the anode cylinder was defined by the existing RADLAC II insulating stacks, and the end voltage was assumed to be 16 MV. With these initial parameters and Creedon equations for minimum current flow *I<sub>l</sub>* to establish self limited magnetic insulation:

$$I_l = 8500 g \gamma_l^3 \ln \left[ \gamma_l + (\gamma_l^2 - 1)^{1/2} \right], \quad (1)$$

$$\gamma_0 = \gamma_l + (\gamma_l^2 - 1)^{3/2} \ln \left[ \gamma_l + (\gamma_l^2 - 1)^{1/2} \right],$$

$$g = [\ln R/r_1]^{-1} \text{ and } \gamma_0 = V[\text{MV}]/mc^2 + 1,$$

we estimate the cathode radii and operating impedances of the entire SMILE line. Our main concern was to keep the current *I<sub>l</sub>* the same or at least not smaller than *I<sub>l</sub>* = 110 kA in all segments.

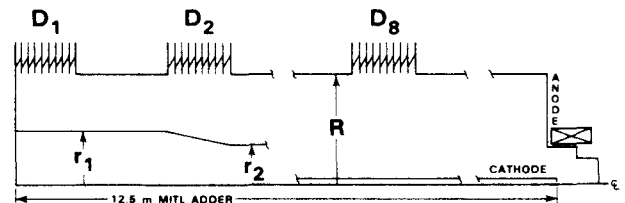

Fig. 1: Schematic cross section of the SMILE adder system

\*Supported by the U. S. DOE contract DE-AC04-76DP00789 and DARPA/AFWL ARPA order No. 5789.

Table I summarizes SMILE dimensions and design parameters. The cathode electrode is 12.5 m long and is cantilevered from the low voltage end of the accelerator. It starts with a 10-cm radius cylinder at the cathode end plate and tapers off to 1-cm radius at the A-K gap of a magnetically immersed foilless diode (Fig. 2). Seven conical tapers have been utilized along with seven cylindrical sections and an equal number of flex-adjusting, double washer sections. The outer shell (anode cylinder) is formed by eight 21.6-cm-inner-radius insulating stacks (feeds) alternating with seven stainless steel cylinders, plus the final anode extension cylinder. The cathode electrode (Fig. 3) is preloaded before insertion into the anode cylinder to compensate for gravitational droop. The final adjustment is made in situ. Because of the large difference in radius between anode and cathode shank, precise alignment and centering of the cathode stock inside the anode cylinder is not very critical since the electrical potential is a logarithmic function of the radii.

The magnetically-immersed foilless diode design (Fig. 4) is similar to that of the IBEX accelerator(6) and actually utilizes the same pancake coil assembly. The anode extension cylinder makes it possible to locate the diode outside of the water tank and greatly facilitates operations and produced beam parameters evaluation.

The design of Table I was validated with a number of MAGIC simulations. The calculated impedances agree with the minimum parapotential theory(4) within 10%. Figure 5 compares the voltage input of each feed with the MAGIC simulated voltage output applied at the A-K gap of the electron diode. Because of the lack of flat top wave forms at the input, the peak output voltage is not 16 MV but only ~ 14MV. This is due mainly to inductive losses and some impedance mismatch at the load end.

The main differences between HERMES III(1) and SMILE designs are the current or operating impedances and the length of the voltage feeds. The RADLAC II feeds are 50 cm long while HERMES III are only 3.8 cm. This makes SMILE almost a "continuous" adder, the first of its kind. Another first is that SMILE is the highest impedance 16 MV MITL voltage adder. The final operating impedance is 140 ohm versus 30 ohm of HERMES III. These differences made the design,

TABLE I.  
SMILE Self-Limited Minimum Current MITL Design

MITL Segment $i$	Segment Voltage $V_i$ [MV]	Optimum Cathode Radius $r_i$ [cm]	Actual Cathode Radius $r_i$ [cm]	Vacuum Impedance $Z_i$ [ $\Omega$ ]	Operating Impedance $Z_i$ [ $\Omega$ ]
1	2.0	13.33	10.2	45.3	30
2	4.0	8.05	7.6	55	40
3	6.0	6.30	5.7	80	61
4	8.0	3.86	3.5	96	80
5	10.0	2.69	2.5	121	97
6	12.0	1.90	1.6	149	122
7	14.0	1.35	1.3	162	135
8	16.0	.952	1.0	180	151

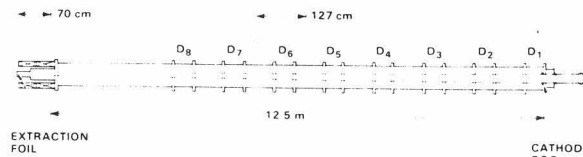

Fig. 2: SMILE configuration

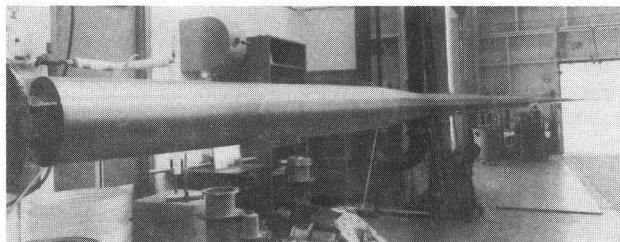

Fig. 3: SMILE cathode electron before insertion into the anode cylinder

### RADLAC-II/SMILE FOILLESS DIODE AND EXTRACTION DIAGNOSTICS

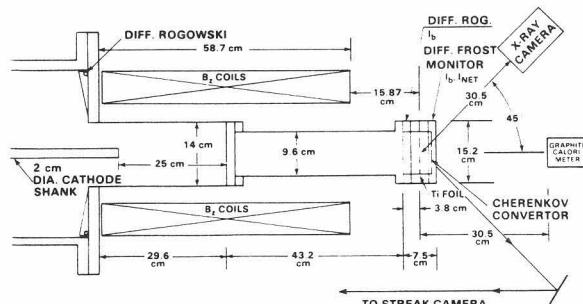

Fig. 4: Schematic diagram of the immersed foilless diode with beam diagnostics

construction and operation of the SMILE adder very challenging.

Computer-generated movies of SMILE simulations clearly show that we have self-magnetic insulation for a large part of the input voltage wave form. There are some electron losses at the beginning and at the end of the voltage pulse. This is to be expected since self-limited magnetic insulation is established by driving some electron current at the anode wall during the rise time of the voltage pulse. The losses during the fall time are due to the fact that the following current drops below the minimum current  $I_{\theta}$  and the line loses self-magnetic insulation. Figure 6 shows an electron map at 75 ns following the arrival of the voltage pulse at the first feed ( $t = 0$ ). The line is magnetically insulated. The losses near the cathode tip are due to the radial component  $B_r$  of the applied magnetic field of the immersed foilless diode. They occur at the point where the self field  $B_{\theta}$  becomes equal to the  $B_r$  component of the applied field.

A number of electron diodes were studied to fit the end of SMILE. Among them the magnetically immersed foilless diode of Figure 4 was selected because it provides the canonical angular momentum to the extracted electron beam necessary for the  $B_\theta$  wire conditioning cell.

**Experimental Results**

The SMILE operates very reliably, consistently producing high quality, high current electron beams with parameters repeating themselves from shot to shot. From the first shot we extracted from the diode magnetic field and into full pressure air thin annular beams with radius  $r_b \leq 2$  cm. The preliminary beam transverse velocity component estimates from the annulus thicknesses are less than 0.1. The voltage and current wave forms are similar to those of the first SMILE shot shown in Figure 7. We can vary the extracted beam current by changing the A-K of the diode (Fig. 4), the strength of the  $B_z$  field, or both. The observed beam radius and emittances are in good agreement with diode numerical simulations. One possible explanation for the obtained low temperature beam is that all the sheath electrons of large radius escape to the anode following the radial magnetic flux lines of the applied  $B_z$  field.

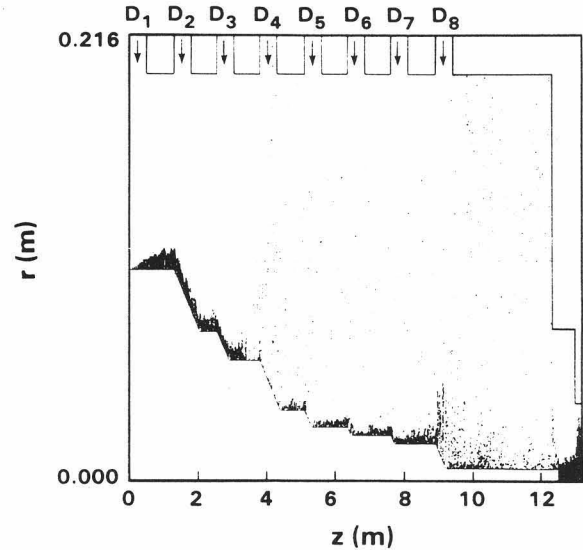
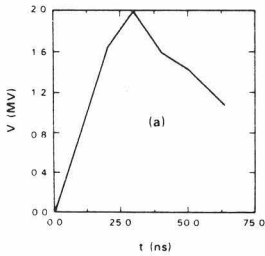

Fig. 6: Electron map for SMILE obtained with MAGIC PIC code at  $t = 75$  ns from the energization of the first insulating Stack  $D_1$

**V (T), INPUT VOLTAGE PER FEED**



**VOLTAGE ON A-K GAP**

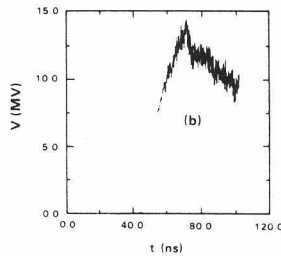

Fig. 5: Time dependance of RADLAC/SMILE input voltage (a) and combined 8-feed voltage output at the A-K gap of the foilless diode

**FIRST SHOT WITH SMILE**

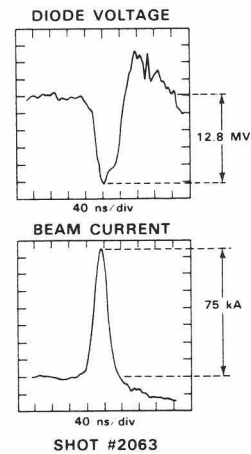

Fig. 7: Voltage and current wave forms of the SMILE magnetically insulated diode

**Conclusions**

We have designed and installed into the RADLAC II water tank a self-magnetically insulated transmission line SMILE. The coaxial transmission line replaces the original beam line with the solenoidal magnets and accelerating gaps and performs the voltage addition along the long cathode shank. The total voltage is applied at the A-K gap of a magnetically immersed foilless diode located at the end of the coaxial line outside the water tank.

SMILE operation is reliable and reproducible, consistently generates beams with low transverse velocities ( $\sim 0.1$ ) and small radii ( $\sim 1$  cm). The beam currents can be varied between 50 and 100 kA by changing diode parameters as predicted by MAGIC simulations.

**References**

1. M. G. Mazarakis, et al., Bull. Am. Phys. Soc. 35, No. 4, 931 (1990).
2. R. C. Pate, et al., Proc. 6th International IEEE Pulsed Power Conference, Arlington, VA, p. 478 (June 29-July 1, 1987).
3. J. J. Ramirez, et al., Proc. 5th International IEEE Pulsed Power Conference, Arlington, VA, p. 143 (June 10-12, 1985)
4. J. H. Creedon, J. Appl. Phys. 48, No. 3, pp. 1070-1077 (1977)
5. See paper "Numerical Models of Injectors for High-Current Electron Linacs," by J. W. Poukey and M. G. Mazarakis, this conference.
6. M. G. Mazarakis, et al., J. Appl. Phys. 62, 4024 (1987).