

Tuning and Conditioning of RFQ1-1250 Cavity*

J. Y. Sheikh and R. J. Burton
 AECL Research, Chalk River Laboratories
 Chalk River, Ontario, Canada K0J 1J0

Abstract

RFQ1-1250, a "new-vane" version of our original RFQ1-600 cw radiofrequency quadrupole proton linac, has vanes designed for a peak surface electric field of 1.8 Kilpatrick and a beam output energy of 1.25 MeV. The RFQ1-600 vanes had OFHC copper tips brazed to copper electro-plated mild steel bodies; the new RFQ1-1250 vanes are fabricated from a relatively new material called GlidCop Al-15, an alumina dispersion-strengthened copper. Installation of the vanes, tuning, and cavity conditioning went smoothly and considerably faster than on the original accelerator. Details of the tuning and the cavity conditioning are described.

Introduction

The RFQ1 facility [1] is a test bed for the development of 100% duty factor RFQ accelerators suitable for a wide range of applications requiring high-current beams of protons or other light ions. Experiments with the original structure (RFQ1-600) were completed during 1991 and new vanes were installed to double the output energy to 1.25 MeV. The increased energy gain in the same resonant cavity was achieved through a combination of designing for higher peak surface fields (1.8 instead of 1.5 Kilpatrick) and a new tip profile with increased accelerating gradient. New mechanical construction techniques were used [2] and the experimental program for RFQ1-1250 includes the characterization of the high-strength copper alloy (GlidCop AL-15) in high-field accelerator applications. Tuning of the resonant cavity with the new vanes was accomplished by following the basic procedures developed for the original structure [3]. RF conditioning of the new vanes to a higher field level was significantly easier than with the OFHC copper-tipped vanes of RFQ1-600.

Tuning

The vanes were installed in the structure, optically aligned and centred to within ± 0.025 mm. After mechanical alignment of the vanes, the relative field distribution within the cavity was checked using frequency perturbation methods. Segment-to-segment and end-to-end magnetic fields were examined by introducing a metal perturber at fixed locations around the cavity outer walls. The frequency shift, which is proportional to the square of the magnetic field, was measured. For

confirmation, a traditional bead pull was done through the strong electric fields in the vane tip region. The field distributions obtained by these two methods were very similar. Measurements made before the vane coupling rings (VCR's) were installed showed an end-to-end field variation of 15%. Appropriate adjustments to the vane positions reduced this tilt to 10% and the VCR's were then installed. End compensation stubs for the VCR's were not as effective as with RFQ1-600. Fields at the middle of the RFQ were nearly 10% higher than at the ends. Segment-to-segment variations were $< 4\%$. Field variations of this magnitude do not significantly degrade beam performance, and assembly was therefore completed for conditioning and high-power testing.

A typical longitudinal field variation, measured in quadrant 4, is shown in Fig. 1. An automated bead pull system, partly developed for this project, is described in detail in a paper presented at this conference [4].

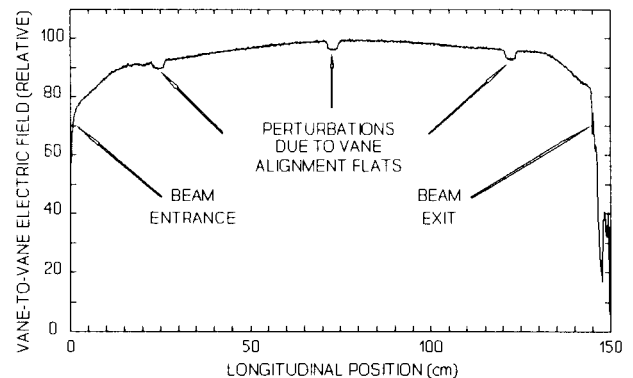

Fig. 1 A typical bead pull through one quadrant along the axis of the RFQ1-1250 cavity showing variations in relative field amplitude.

The predicted (SUPERFISH) resonant frequency of the cavity, with corrections for the end effects as determined from RFQ1-600, was 267 MHz. At the conclusion of low-power tuning, the 0 and 1st-order quadrupole and dipole mode frequencies were measured (Table 1). These measurements showed that the desired frequency was within 180 kHz, well within range of the motor-driven tuners.

*This work was partially supported by Los Alamos National Laboratory under contract No. 9-X5D-7824D-1.

Table 1

	Frequency	Q (loaded)	Mode Type
n=0	266.820	3106	quadrupole (accel. mode)
	275.108	1687	dipole
	275.632	3982	dipole
n=1	285.734	6235	quadrupole
	324.608	6387	dipole (degenerate)

High-Power Conditioning

For conditioning it is desirable to use high-power short-rise time pulses to break through multipactoring. However, the present rf system is not designed for pulsed operation and any extended operation in the pulsed mode results in excessive heating of the power-supply filters' circuits. Therefore, our strategy for conditioning was to use the pulsed mode as little as possible and do most of the conditioning in cw mode.

After pulsing for 22 minutes using 30 μ s pulses at 100 Hz, cw operation was tried. The tank accepted about 40 watts after 15 minutes. The system vacuum was used as a guide to the multipactoring activity and as an indicator to when the power could be increased further. With no rf in the tank, the vacuum was approximately 3×10^{-7} torr; as power was increased, it was kept in the mid- 10^{-6} range to avoid sparking. Two TV cameras, one on-axis and one across from the drive loop, were used to observe sparks in the tank. For protection against the high reflected power, an rf trip circuit removed the low-level drive if it persisted beyond a preset time. Initially, the trip was set for 2.6 kW and 58 ms. This was increased to 30 kW and 100 ms during conditioning to full power. X-ray end-point measurements at 120 kW predicted that 150-155 kW would give the required intervane voltage of 78 keV.

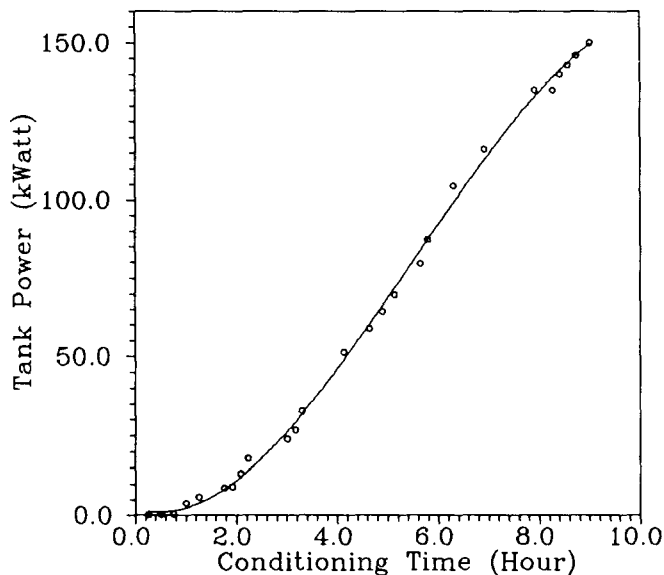

Fig. 2 High-power conditioning versus time.

Conditioning the tank to 150 kW took about 16 hours, spread over seven days. Figure 2 shows the conditioning history, neglecting the time at the start of each day required to reach the level attained the previous day.

During conditioning, it was noted that the resonant frequency of the tank was changing. Figure 3 shows the change in the cold frequency shift over the seven-day conditioning period.

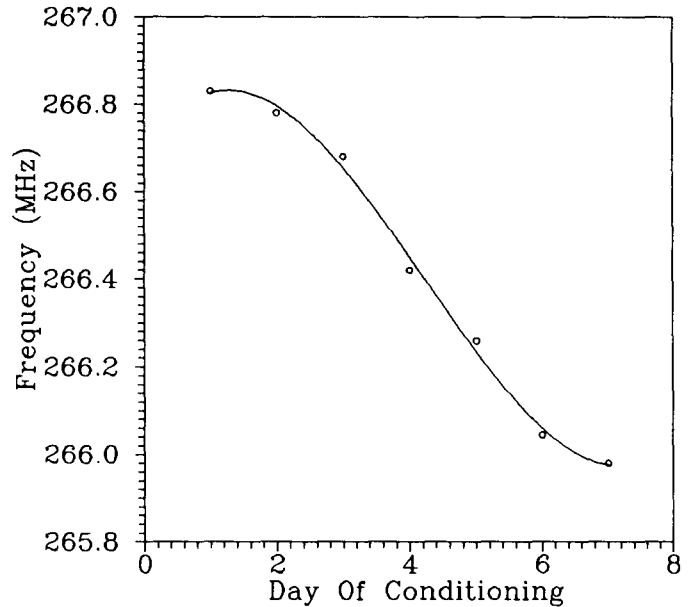

Fig. 3 Frequency shift versus the day of conditioning.

The ends of the RFQ1-1250 cavity were removed for inspection and it was confirmed that the vanes had moved by as much as 0.2 mm at the high-energy-end and about half this amount at the low-energy-end. This shift was corrected and the frequency was restored close to the original value. No comparable shift was noticed during the RFQ1-600 conditioning. This may be because it took several weeks to achieve a well-conditioned tank and, during that period, the tank was opened several times. The cumulative 700 kHz frequency change was attributed to minor modifications.

A new automatic frequency controller (AFC) was recently installed on the rf system. Previously, the signal generator tracked the cavity by modulating the low-level rf signal at 2 kHz. The AFC extracted the modulation signal from the reflected power and compared it with the reference to develop a dc correctional signal proportional to the frequency error. The new unit measures the frequency error by comparing the phase of the rf power entering the structure with the phase of the fields in the structure. The difference between these two signals is used to determine the polarity and magnitude of the frequency error and drives the dc-coupled FM input of the signal generator to bring the phase error to zero.

The sparking frequency appears to be much reduced with the new AFC. An increased intervane voltage of 94 keV (peak fields of 2.1 Kilpatrick) has been reached with this system, as shown in Fig. 4.

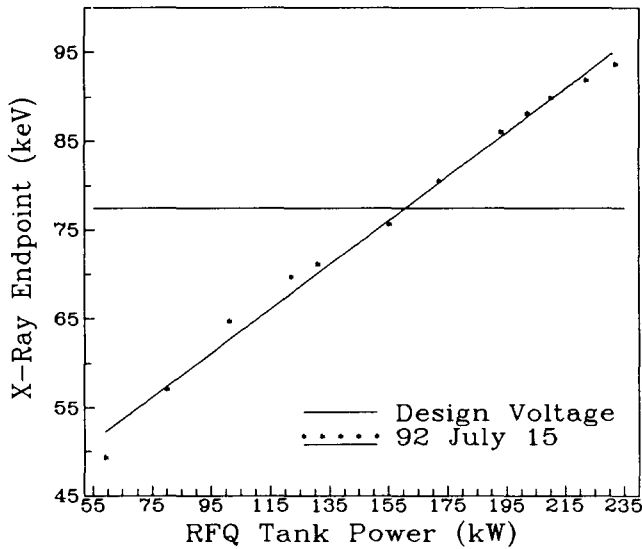

Fig. 4 X-ray measurements.

The rf power is coupled to the structure via a single drive loop. The adjustment for rf coupling is done by rotating the loop and adjusting its penetration in the tank. When first installed, the loop was over-coupled. The 3 mm (0.080") rf gasket (Fig. 5) had to be increased in thickness to 35 mm (0.880") to reduce the coupling (but at the expense of introducing a ≈ 300 kHz frequency shift). A new loop that removes this shift was recently built. Further mechanical design improvements were also made, that reduced the number of parts and allow easier assembly and disassembly. A section of the new loop with modified end-shape is shown in Fig. 6. This loop was recently tested on the RFQ1-1250. Apart from minor modifications to the tank tuners for frequency adjustment and a few hours of conditioning, the loop delivered power without problem. The coupling and frequency shift are as designed.

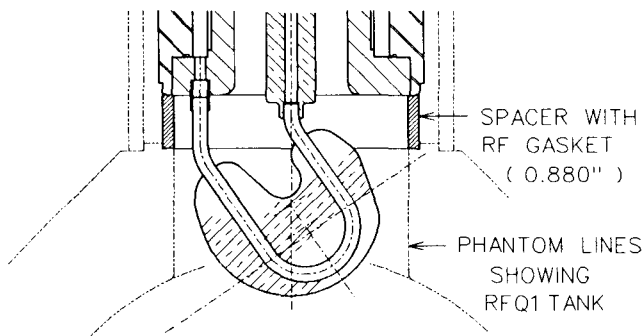

Fig. 5 Old loop with spacer.

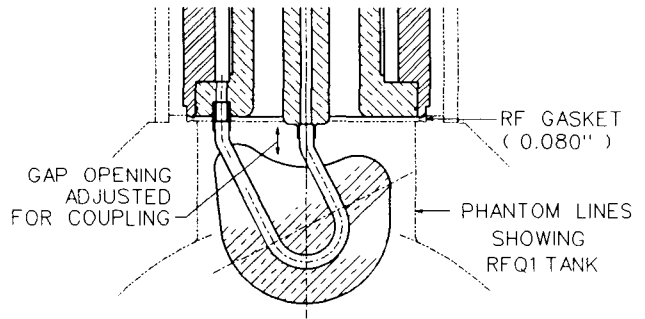

Fig. 6 Section of the new loop.

Conclusions

The initial rf conditioning of high-power devices is often difficult because a number of systems are usually being operated for the first time. For RFQ1-1250, the cw conditioning was noticeably faster than for RFQ1-600. Glidcop AL-15 proved similar for conditioning to OFHC copper. The rest of the structures had been conditioned with the old vanes. The rf circuit that was installed to shut off the low-level drive if reflected power stayed high helped in conditioning by improving the overall rf system operation, and relieving the crowbars of unnecessary stress. The new AFC has significantly reduced the frequency of tank sparking and allowed the tank to condition to 2.1 Kilpatrick cw. The modified loop conditioned quickly to full power.

References

- [1] G.M. Arbique, B.G. Chidley, W.L. Michel, G.E. McMichael and J.Y. Sheikh, "Beam Transmission and Emittance Measurements on the RFQ1 Accelerator", Proceedings of the 1991 Particle Accelerator Conference, IEEE Conf. Record #91CH3-38-7, (1991) 845.
- [2] B.G. Chidley, F.P. Adams, G.E. McMichael, T. Tran Ngoc, "New Vanes for RFQ1", Proceedings of the 1990 Linear Accelerators Conference, LA-12004-C, (1991) 42.
- [3] R.M. Hutcheon and R.A. Vokes, "Low Power Tuning of The RFQ1 Accelerator", unpublished report, RC-36, available from Scientific Document Distribution Office, Chalk River Laboratories, Chalk River, Ontario, KOJ 1J0 (1988 March)
- [4] B.H. Smith, R.J. Burton, R.M. Hutcheon, "High Speed Resonant Frequency Determination Applied to Field Mapping Using Perturbation Techniques", these proceedings.