

COOL-DOWN PERFORMANCE OF THE CORNELL ERL CRYOMODULES

R. Eichhorn[†], M. Ge, F. Furuta, G.H. Hoffstaetter, M. Liepe, S. Markham, T. O'Connell, P. Quigley, D. Sabol, J. Sears, E. Smith, V. Veshcherevich, D. Widger
CLASSE, Cornell University, Ithaca, NY, USA

Abstract

In the framework of the ERL prototyping, Cornell University has built two cryomodules, one injector module and one prototype Main Linac Cryomodule (MLC). In 2015, the MLC was successfully cooled down for the first time. We will report details on the cool-down as well as cycle tests we did in order to achieve slow and fast cool-down of the cavities. We will also report on the improvement we made on the injector cryomodule which also included a modification of the heat exchanger can that allows now a more controlled cool-down, too.

INTRODUCTION

During an NSF funded R&D phase for an Energy Recovery Linac (ERL), Cornell University has built two cryomodules. The injector cryomodule (ICM) completed in summer 2007 was designed and built to demonstrate high current generation and achieving low emittances.

The second cryomodule built was the main linac cryomodule (MLC) which is supposed to demonstrate highly efficient cw operation. This module was completed by the end of 2014 and cool-down for the first time in fall 2015.

INJECTOR CRYOMODULE

Rebuilt of the Module

While the emittance goal for the injector has been reached [1], the current achieved so far is 75 mA. As of today this is a world record performance [2]. However, the goal set for the ERL was 100 mA. In ramping up beam current, RF power transmitted by the coupler increases. Every cavity is fed by 2 couplers, being designed for a cw power of 60 kW. As we learned, pushing for higher currents we realized that heating of the 80 K thermal intercept of the power couplers became a limitation. We were able to track down to insufficient cooling of the 80 K intercepts to a lack of cryogenic flow [3]. These intercepts are cooled by a stream of parallel cryogenic flows which we found to be unbalanced.

In preparation for building an FFAG based ERL, the injector cryomodule had to be moved, giving us the chance to modify the piping as described. While the actual modification of the piping was only two days of work, disassembling and reassembling the module required 6 month of labour as we almost had to strip down the cold-mass.

In fall 2015, we added a flow restrictor to the HOM cooling channels that previously has stolen all the flow from the couplers. The restrictor consisted of an additional pipe with an adjusted the length of up to 87 cm. A par-

ticular difficulty was that available piping is usually specified by its outer diameter, while the inner diameter (being relevant for the cryogenic flow) fluctuates significantly. Eventually we bubble-tested all pipes to be assured the all have the same flow impedance[4].

Improvement in the HX can

Prior to re-cool the ICM we decided to modify the heat exchanger can (HXC), to incorporate the experience we had gained during the past years of operation. The can (in a 3-D design and as a photo) is shown in Fig. 1.

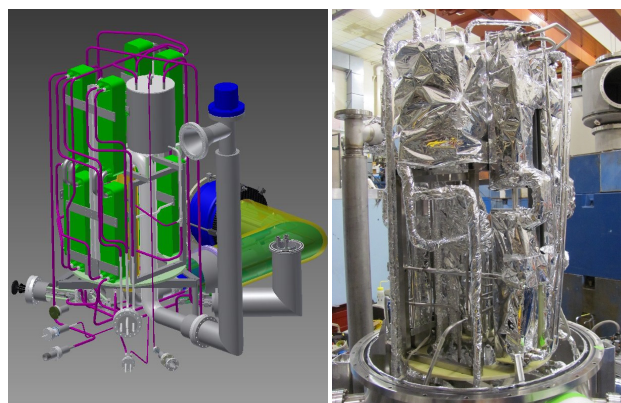

Figure 1: heat exchanger can for the injector cryomodule, sketched and in picture.

Our first HXC in this style used a pair of inlet and outlet valves, rather than pressure regulators to establish flow rate, and a common flow stream for cooling both the 5 K and 80 K loads, using two separate 80 K cooling loops in series to get adequate mass flow. It required both the 5 K and 80 K coolant streams to be near the same pressure, and was harder to cool down from room temperature in a smooth fashion. The JT valve was contained in the HXC, rather than in the cryomodule.

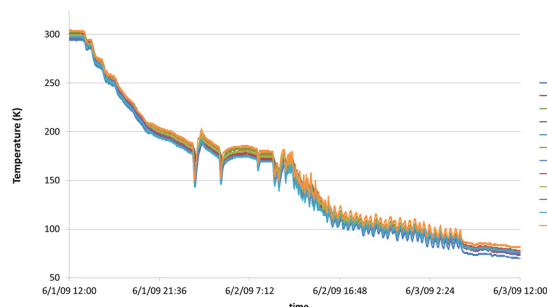

Figure 2: Typical cool-down profile of the ICM using the initial heat exchanger can. Rather huge transients can be seen as well as oscillations on the cooldown from nitrogen to helium temperatures.

[†] r.eichhorn@cornell.edu

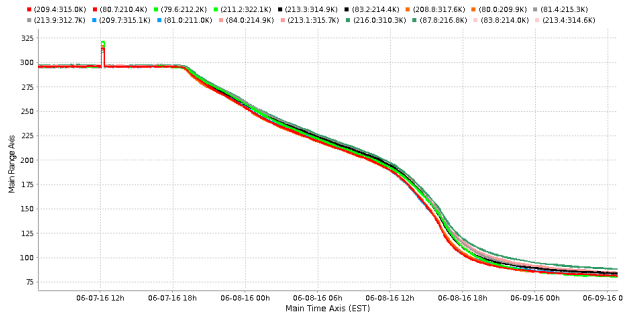

Figure 3: Cool-down profile of the ICM using the modified heat exchanger can.

A typical cool-down profile is given in Fig. 2. Even when tightly controlled and adjusted by personal large temperature fluctuations can be seen, sometime exceeding 40 K. In addition, when going from 77 K to 4 K huge oscillations in temperature occur. This is the result of the approach, trying to control the temperature by the level of liquid nitrogen in the thermosiphon- which we found not to be practical.

Based on the success of the slightly modified design of the MLC heat exchanger can (described below) we modified the ICM-HXC. The most remarkable change made is the addition of two cooldown lines to allow a better control. In addition, back pressure regulators were added to stabilize flow rates. The first cooldown of the ICM with the modified can turned out to be extremely smooth (see Fig. 3) and did not require much adjustments.

MAIN LINAC CRYOMODULE

First Cool-down

In order to facilitate a smooth and controlled cool-down, a new heat exchanger can was built. The piping diagram is given in Fig. 4, more details can be found in [5].

During the cool-down, it allows to add a warm stream

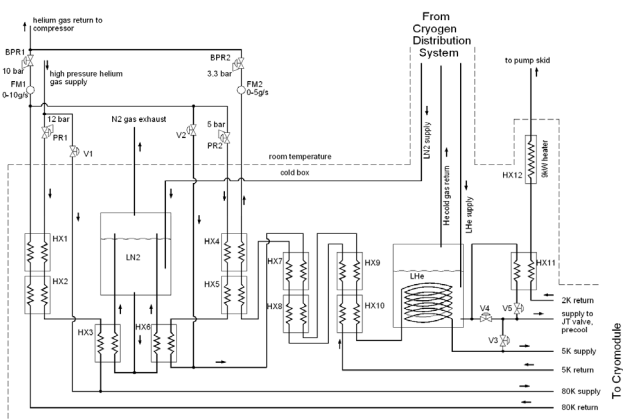

Figure 4: Piping diagram of the heat exchanger can being built for the main linac cryomodule. As by design the module has to be cool-down extremely smoothly avoiding large gradients special cool-down pipes were added.

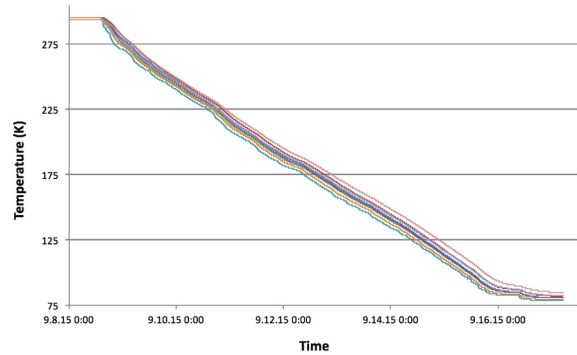

Figure 5: Temperatures on the thermal shield during the cool-down. Due to the design of the thermal shield the temperature spread across the shield had to stay below 20 K, leading to a cool-down rate of ~1.25 K/h.

of gas forwarded to the cold-mass, resulting in a very controlled process. This was mandatory as the thermal shield is cooled by conduction only with an extruded pipe running just along one side. As a result, the cool-down of the shield is asymmetric and we calculated stress limits on the aluminum transitions- which required us to keep the temperature spread across the shield below 20 K. In the initial cool-down we maintained 10 K, becoming 15 K at 200 K with an average cool-down rate of 1.25 K/h. The temperature profile during the cool-down is given in Fig. 5.

Based on the success of this heat exchanger can we modified the ICM-HXC, adding the cool-down lines and back pressure regulators as described above

Slow and Fast Cool-down

Recent findings have indicated that the performance of an SRF system also depends on details of the cool-down process. Findings at Cornell indicate that for conventionally treated cavities a slow cool-down leads to a higher quality factor of the cavity [6]. We were able to explain this finding by describing the role of thermo-currents that are excited at the material transitions between the niobium (cavity) and the titanium (enclosing helium vessel), driven by temperature gradients [7]. So-called nitrogen-doped cavities, however, seem to require a fast cool-down and it was found that this helps expelling residual magnetic field more efficiently than a slow cool-down [8].

We therefore went through a total of 5 thermal cycles, trying very slow and extremely fast cool-downs. Mostly, we were interested in understanding the slow and fast limitations on the cool-down speeds for a cryomodule as a whole which is hard to predict.

Figure 5 shows the temperatures at each cavity during a slow cooldown. As can be seen the cavities get colder one by one starting from the filling end. We found that slowing down the cool-down is sometimes difficult to time and some of the cavities went through the critical temperature twice. However, the cooldown rate was more or less the same for all cavities.

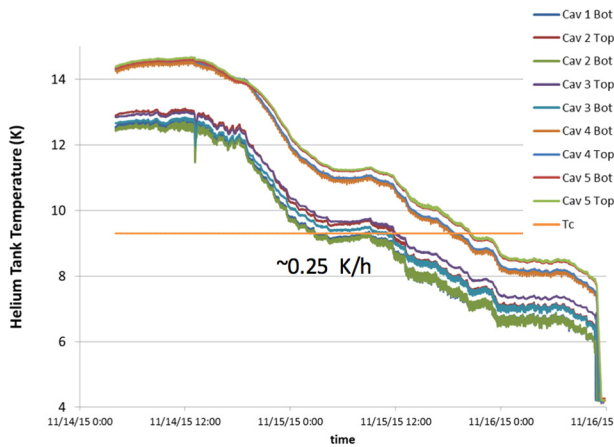

Figure 5: Slow cool-down cycle performed in order to measure cycle dependant impacts on the cavity performance. For the slow cool-down we were able to get 0.25 K/h relatively uniform over the cryomodule.

In Fig. 6 the cooldown profile during a fast cool-down is given. The cooldown rate we achieved was more than 100 times faster compared to the slow cool-down. In contrast to the slow cycle we found that cavities closer to the filling end cooled down faster than downstream cavities giving a factor of 4 variation in the cool-down speed.

Test results from all 6 cavities are summarized and Tab. 1. After some initial processing 5 of the 6 cavities perform close to their design specifications, easily reaching the design gradient. One cavity is currently limited by a premature quench which we hope to overcome by a thermal cycle and pulse processing.

We also found that for our cavities being conventionally treated (BCP, 120 C bake, HF rinse), the cool-down speed did not significantly affect the cavity performance, which is different from our earlier findings [6].

Our understanding is that optimum the cooldown speed is determined by two counteracting effects: the generation of thermocurrent induced magnetic fields as a result of a large thermal gradient and the flux expulsion of residual magnetic field being more efficient if transients are high. Depending on the cavity treatment (N doped or not) and the amount of residual magnetic field a fast or a slow cool-down might produce better Qs.

In our case the magnetic shielding in our short HTC module was obviously more efficient which made the thermocurrents the dominant factor favouring therefore a

Table 1. Cavity Performance inside the Cryomodule. Qs are Given for Fast (f) and Slow (s) Cool-Down

	$Q_0 / 10^{10}$ (f)	$Q_0 / 10^{10}$ (s)	E_{acc} [MV/m]
Cavity #1	1.88	2.11	16.0
Cavity #2	1.41	2.01	16.2
Cavity #3	1.78	1.98	16.2
Cavity #4	1.38	1.45	13.7
Cavity #5	2.21	2.08	16.0
Cavity #6	0.80	0.82	16.0
<i>Design</i>	<i>2.0</i>	<i>2.0</i>	<i>16.2</i>

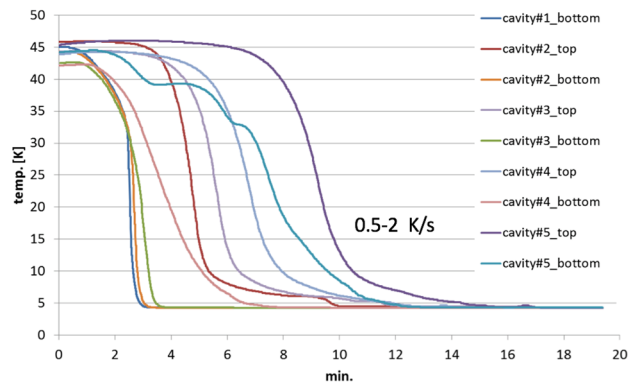

Figure 6: Cavity temperatures during the fast cool-down resulting in a speed of 0.5 K/min to 2 K/min, depending on how close the cavity was to the JT valve.

slow cool-down. Within the long MLC module magnetic field levels are probably higher making flux expulsion more of a factor.

SUMMARY AND OUTLOOK

The initial cool-down of the main linac cryomodule was very smooth and successful. We demonstrated the ability to perform fast and slow cool-downs of a full cryomodule and investigated limitations.

In addition, we rebuilt the injector cryomodule to resolve the coupler heating issue in the hope to successfully push for higher beam currents. Beam operation of the module has just resumed and we hope to report results soon.

REFERENCES

- [1] C. Gulliford *et al.*, *Phys. Rev. ST Accel. Beams* 16, 073401 (2013).
- [2] B. Dunham *et al.*, *App. Phys. Lett.* 102.
- [3] R. Eichhorn *et al.*, in *Proc. of the 2013 Int. Conf. on RF Supercond.*, Paris, France (2013) 259.
- [4] R. Eichhorn *et al.*, in *Proc. of the 2016 Intern. Part. Acc. Conf.*, Busan, Korea (2016) 2298
- [5] E. Smith *et al.*, IOP Conference Series: Materials Science and Engineering (MSE), in press
- [6] N. Valles *et al.*, in *Proc. of the 2013 Int. Conf. on RF Supercond.*, Paris, France (2013) 300.
- [7] R. Eichhorn *et al.*, *Phys. Rev. Accel. Beams* 19 (2016) 012001.
- [8] M. Ge *et al.*, in *Proc. of the 2015 Int. Conf. on RF Supercond.*, Whistler, BC, Canada (2015) 328.