

PERFORMANCE OF SRF CAVITY TUNERS AT LCLS II PROTOTYPE CRYOMODULE AT FNAL

J. Holzbauer[#], Y. Pischalnikov, W. Schappert, J.C. Yun, FNAL, Batavia, IL 60510, USA

Abstract

A compact tuner was designed at Fermilab for the LCLS-II project. The focus of this design with high reliability, including robust active components (electromechanical actuators and piezo actuators) as well as the ability to replace these components without cryomodule disassembly. These tuners have been prototyped and tested in detail on test cavities [1]. Performance of the slow/fast tuners mounted on the eight SRF cavities of the first LCLS-II prototype cryomodule (pCM) assembled at FNAL will be presented.

TUNER DESIGN

Schematics of the tuner design are shown in Figure 1. Coarse tuner is a double lever tuner (with 20:1 ratio) similar to design of the SACLAY I tuner. The tuner is designed to work in the compression regime. The piezo-stack is installed on the cavity end flange, so its force is directly applied to the cavity, not translated through a lever arm or bearing. This configuration will deliver better piezo-tuner resolution and decrease group delay of the fast tuner. This tuner must protect the cavity from deformation in many different configurations of cavity pressure, helium pressure, and insulating pressure. To ensure protection in all scenarios, safety rods between the cavity end flange and main lever of the tuner were added. These safety rods protect cavity from non-elastic deformation during cavity/helium vessel system leak check.

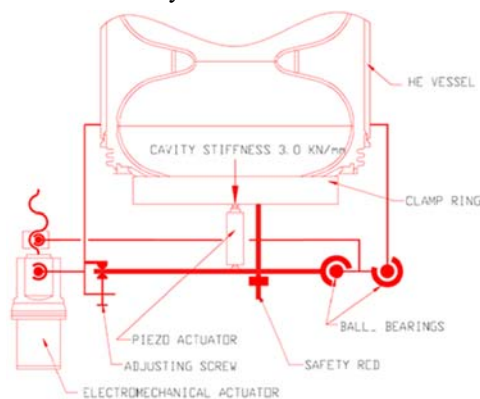

Figure 1: Schematic of the Tuner.

A split ring is attached to the conical flange welded to the cavity beam-pipe (Purple in Figures 2&3). All forces/stroke from tuner to the cavity are translated through this split ring. The tuner is anchored to the helium vessel with two strong horizontal arms (Yellow in Figure 2). The

electromechanical actuator connects the left arm and lever system attached through bearings to right arm.

A special adjustment screw (Figure 1) to hold the left side of the lever system to the left arm was introduced into design. This addition allows the release of forces between the cavity and tuner system when either the electromechanical actuator or piezo-stack needs to be replaced through the designated port in cryomodule.

Balls connections were chosen for the connections between encapsulated piezo-stacks and main lever (see Figure 3). This prevents the build-up of shearing forces on the piezo-stack during tuner operation which are detrimental to piezo lifetime. Two adjustment screws (one in each main arm) help to uniformly preload piezo-stacks during assembly.

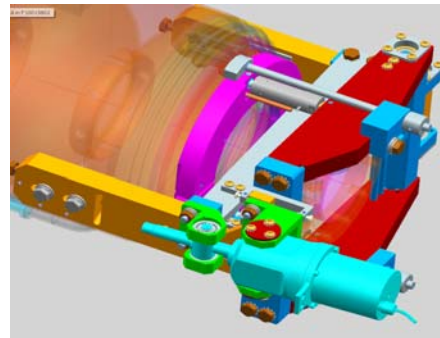

Figure 2: 3-D model of the Tuner, assembled on the cavity/helium vessel system.

PREVIOUS TESTING

Electromechanical actuator is the active element of the slow/coarse tuner. Electromechanical actuator translates rotation of a stepper motor to linear motion of the tuner arms.

Technical requirements call for a tuning sensitivity of 1-2 Hz/step. The selected electromechanical actuator has 200 steps per shaft rotation, gear ratio of 1:50, and spindle pitch of 1 mm. 1 motor step will shift tuner $1\text{mm}/200 \times 50 = 1\text{e-}4$ mm. With tuner ration of 1:20, this step will compress cavity $5\text{e-}6$ mm. Given a cavity sensitivity of 300 kHz/mm, this gives a tuning of $\Delta F = 1.5\text{Hz}$.

Cold testing in the Horizontal Test Stand [2] at Fermilab give a tuning sensitivity of 1.4 Hz/Step and a lash of 30 steps. Short and long range scans (Figures 4 and 5) gave consistent results, down to the limit of the frequency measurement.

*This manuscript has been authorized by Fermi Research Alliance, LLC under Contract N. DE-AC02-07CH11359 with U.S. Department of Energy.

[#]jeremiah@fnal.gov

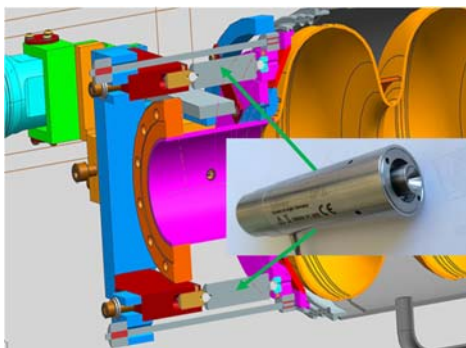

Figure 3: 3-D model (Cross-section) of the SRF cavity/helium vessel/tuner system. Shown details of the force/stroke translation from main lever to the cavity flange through two encapsulated piezos (on the top and bottom). Insert is photo of the encapsulated piezo unit.

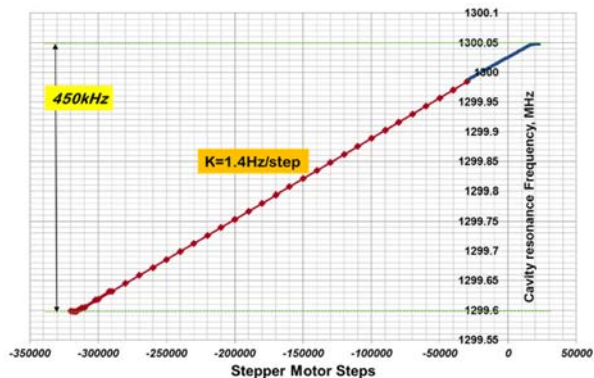

Figure 4: Cavity tuning with slow/coarse tuner. Range of the tuner is 450 kHz set by hard stops.

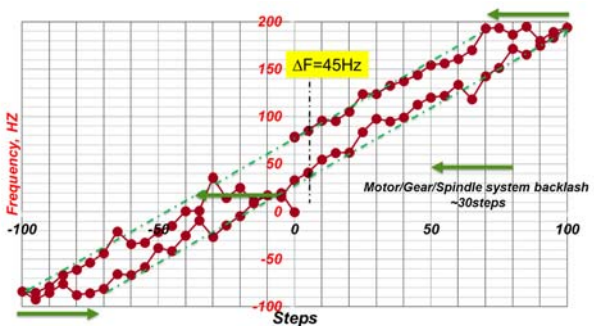

Figure 5: Coarse Tuner performance in the short (300Hz) cavity tuning range. Increment is 5 steps of the stepper motor.

Piezo actuator used in this tuner is an encapsulated piezo-capsule designed and built by Physik Instrumente (PI) [3] per FNAL specification. Inside are two 10*10*18mm PICMA piezo-stacks butted together. If (when) one of the piezo stacks break-down, the other piezo can work with double voltage. In our tuner we are using 4 piezos (2 on the top and 2 on the bottom piezo capsule). One piezo can deliver the specified cavity elongation, if required.

Static cavity tuning with DC voltages from 0-100 V applied to all four piezos is shown in Figure 6. The sensitivity observed was -6 Hz/V per piezo. Energizing combinations of piezos gave a linear sum of responses. The measured capacitance of the piezos for this test was ~3.6 uF.

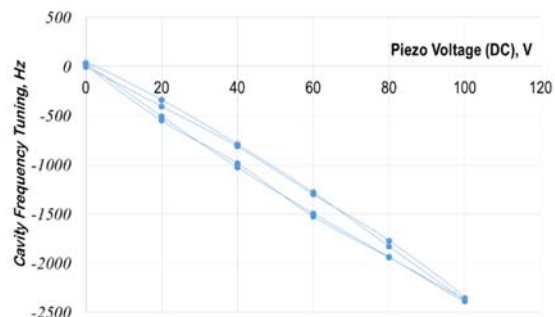

Figure 6: Cavity static detuning by piezo tuner when DC voltage applied to all 4 piezo simultaneously.

CRYOMODULE PERFORMANCE

Eight of these tuners were fabricated and installed on the prototype cryomodule for LCLS-II (see Figure 7).

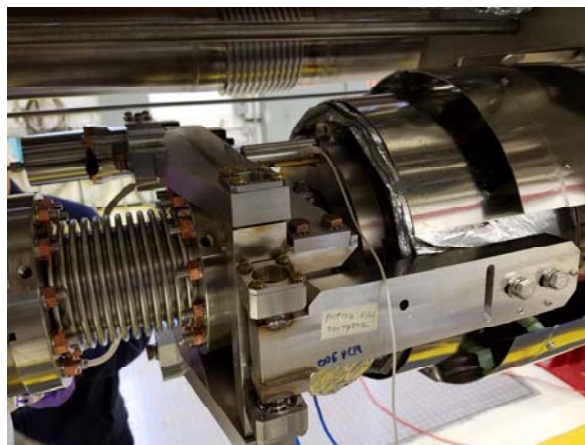

Figure 7: LCLS-II tuner as installed on the prototype Cryomodule at FNAL.

This included a preloading on each cavity of ~45 kHz. Each cavity was locked and the ‘cold landing’ frequency was measured. Tuning to 1.3 GHz also gives the tuning sensitivity for each cavity. Table 1 shows the predicted ‘cold landing’ frequency (cavity frequency at 2 K with no further adjustments) versus actual measured cavity frequency as well as sensitivity.

Hysteresis scans of the slow tuner can be seen in Figure 8. The tuner was moved to ±100 steps by 10 step increments. The frequency stability of the cavity limits the accuracy of the measurement, but it was still possible to extract the hysteresis and lash.

Table 1: Measured vs. Predicted Cold Landing Frequency from Cavity Tuning Procedure and Cavity Tuning Sensitivity

Cavity #	Expected CL Position - kHz	Measured CL Position- kHz	Sensitivity [Hz/step]
1	81	149	1.33
2	249	153	1.40
3	173	136	1.37
4	107	176	1.39
5	165	125	1.37
6	125	198	1.34
7	76	259	1.37
8	13	149	1.33

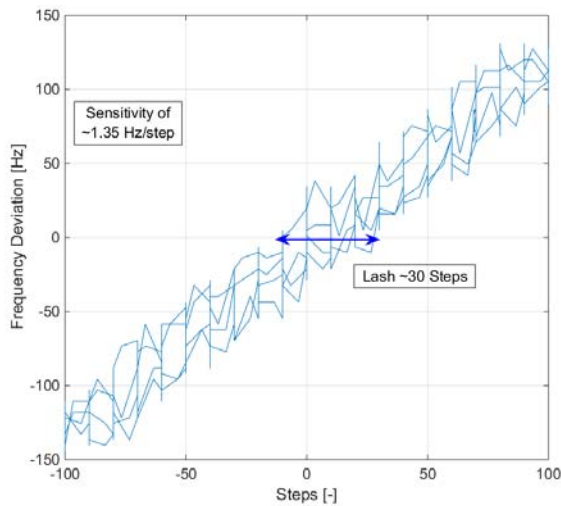

Figure 8: Short range tuner hysteresis measurement of the LCLS-II tuner as measured cold. Measured lash was ~30 steps with a sensitivity of 1.35 Hz/step.

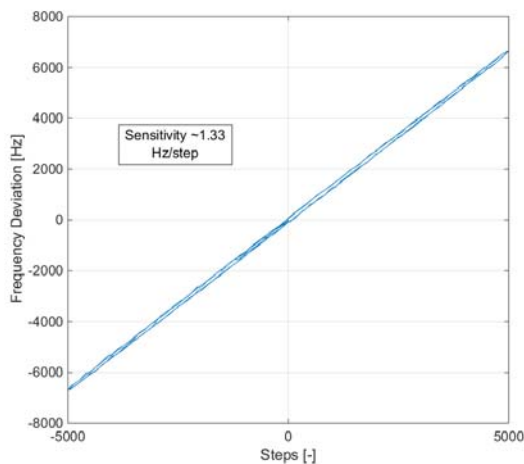

Figure 9: Long range tuner hysteresis measurement of the LCLS-II tuner as measured cold. Measured sensitivity is 1.33 Hz/step.

The measured lash of 30 steps and sensitivity of 1.35 Hz/step is consistent with previous measurements. Long range hysteresis measurements can be seen in Figure 9.

ISBN 978-3-95450-169-4

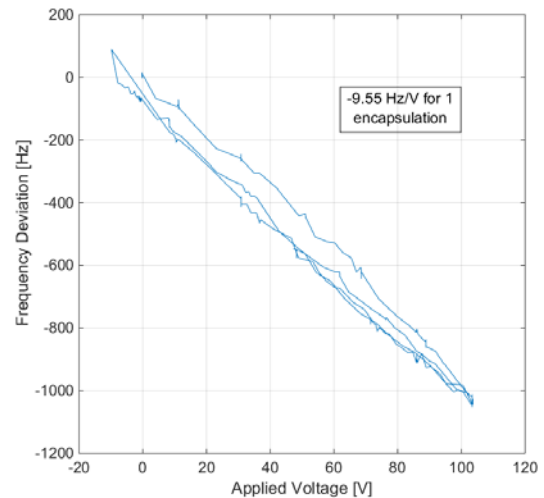

Figure 10: Piezo tuning hysteresis study with one encapsulation (2 piezo stacks in parallel). Measured sensitivity is ~-9.55 Hz/V.

Piezo capacitance, bleed resistor resistance, and polarity were all measured for each piezo stacks. All capacitance and resistance were within line with expectations (~2.5 uF and 270 kOhms).

The measured sensitivity was -9.55 Hz/V for two stacks, seen in Figure 10, giving a full sensitivity of -19.1 Hz/V. Further piezo tuner characterization was prevented by limited testing availability. Previous testing showed a sensitivity of -6 Hz/V, compared to -4.78 Hz/V now. This can be explained by an improved cooling scheme for the piezo tuners compared to horizontal testing, giving a reduced capacitance, and thus sensitivity.

CONCLUSION

A compact tuner design was installed on the LCLS-II prototype cryomodule and successfully tested. The tuner exhibited a range and resolution consistent with expectations for both slow and fast tuning mechanisms.

REFERENCES

- [1] Y. Pischnikov *et al.*, “Design and test of compact tuner for narrow bandwidth SRF cavities.”, in *Proc. IPAC 2015*, Richmond, VA, USA, paper WEPTY035.
- [2] A.Hocker *et al.*, “High power tests of dressed superconducting 1.3GHz RF cavities” in *Proc. PAC2011*, New York, NY, USA, Paper TUP071.
- [3] <http://piceramic.com/product-detail-page/p-844-101210.html>