

# DESIGN ENHANCEMENTS FOR THE SNS RFQ COAXIAL COUPLER\*

G. Toby<sup>†</sup>, C. Barbier, S. Lee, A. Narayan, J. Moss, Y. Kang  
 Oak Ridge National Laboratory, Oak Ridge, USA

## Abstract

The H<sup>-</sup> ion linear accelerator at the Spallation Neutron Source (SNS) at Oak Ridge National Laboratory operates with reliability that routinely surpasses 90% during scheduled beam operation. With the ambitious goal of eventually achieving at least 95% availability, several upgrade and improvement projects are ongoing. One such project is the modification of the coaxial couplers that transfer radio frequency (RF) power to the accelerator's Radio Frequency Quadrupole (RFQ). The proposed modification utilizes stub sections and capacitive coupling to construct a physically separable assembly with DC isolation. With a separated coupler assembly, the section that includes the magnetic coupling loop can be permanently mounted to the RFQ which would eliminate the need to re-adjust the couplers after maintenance activities, upgrades, and repairs. Additionally, the modified design would provide increased multipaction suppression with DC biasing and potentially lower thermal gradients across the device. This paper presents the design and simulation results of the project.

## INTRODUCTION

Beam acceleration at the SNS starts with the front-end systems where an ion source, an RFQ and two beam transport sections are utilized. The 65 keV beam from the ion source is focused, bunched, and accelerated to 2.5 MeV in the RFQ [1]. The 402.5 MHz RFQ is powered by two coaxial couplers that deposit up to 700 kW peak power in 60 Hz, 1 msec pulses. Each coupler is conditioned up to 400 kW, but nominally run at 300 kW during baseline operation [2, 3].

While not a source of significant downtime, the goal of achieving 95% availability during scheduled beam operation necessitated a coupler improvement project. The design of the current RFQ couplers requires each unit to be manually adjusted after repairs and maintenance activities to achieve the proper RF coupling for beam loading. Given the non-autonomous nature of this task, significant time, energy, and several iterations are often needed. Figure 1 shows the current coupler design with a permanent connection that forms a loop antenna between the inner and outer conductors.

RF Systems and Mechanical Engineering personnel at SNS explored several modification ideas with the goal to improve the electrical and mechanical performance of the couplers while reducing accelerator downtime. Of several potential solutions determined, three were selected as candidates for the next phase.

\* ORNL is managed by UT-Battelle, LLC, under contract DE-AC05-00OR22725 for the U.S. Department of Energy. This research was supported by the DOE Office of Science, Basic Energy Science, Scientific User Facilities

<sup>†</sup> tobygd@ornl.gov

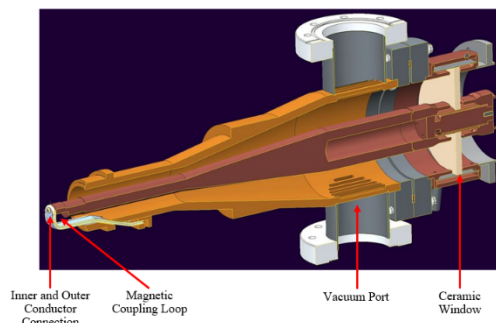

Figure 1: Cross sectional view of the current coupler.

## RF DESIGN

The first target of the improvement project was a design capable of maintaining fixed coupling with the RFQ. The coaxial coupler needed to be separated into two subsections, one containing the ceramic, vacuum window and the other incorporating the coupling loop. This change would make maintenance activities and some repairs, including vacuum window replacements, possible without the need to remove the entire coupler assembly. This separation, however, would require rigid support for the inner conductor with no RF disruption. The need intuitively derived utilizing transmission line short-circuited stub sections and capacitive coupling to achieve that goal. Quarter-wave transmission line sections optimized to transform RF short circuits to open circuits at the center conductor were employed. This approach was selected based on impedance matching, mechanical rigidity and heat sinking. Three types of short-circuited, quarter-wave transmission line sections capable of meeting the requirements were considered. Of the three types shown in Fig. 2, option 1 was selected for simplicity and proof of concept.

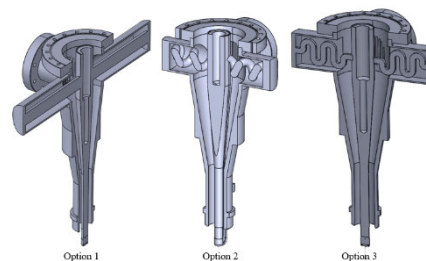

Figure 2: Quarter-wave short-circuited stub design concepts.

## RF SIMULATION AND RESULTS

The first step of the simulation process was simplifying the 3-D model by removing the magnetic coupling loop antenna. Quarter-wave stub sections were added to the model to support the inner coaxial conductor and the coupling pin was designed as a quarter-wave open stub working as an RF short. With the exception of the ceramic window which was modelled as 96% alumina (same as the current coupler ceramic window), the rest of the structure was modelled as pure copper. Figures 3 and 4 show the model and the result of the RF simulation obtained using CST Microwave Studio.

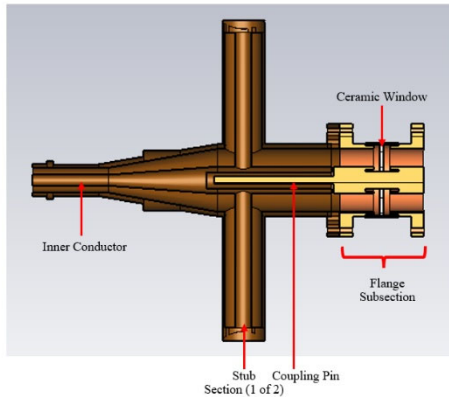

Figure 3: Cross sectional view of the modified coupler (version A).

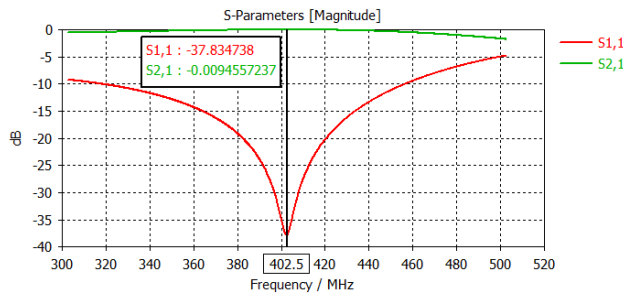

Figure 4: Frequency domain response of the coupler after optimization (version A).

With the proof of concept established, further improvement was targeted. By incorporating 96% Alumina ( $\epsilon_r \approx 9.4$ ), which is a higher permittivity dielectric into the model, the length of the stub and coupling pin sections were shortened by approximately 55% and 67% respectively due to varying geometrical factors. Alumina ceramic was selected because of its low RF loss, high durability, and long-standing reliability which has been demonstrated in the warm and cold sections of the SNS linear accelerator. Figures 5 and 6 show the second iteration of the design and the corresponding frequency response. A third, empirical design that addresses potential surface contact challenges between metals and ceramics associated with manufacturing limitations has been identified. This iteration utilizes shorter dielectric pieces in peak electric field regions in the stub sections for maximum electrical length effect.

Figures 7 and 8 show the design and its associated frequency response.

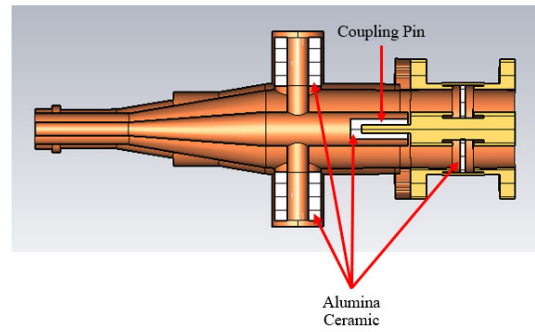

Figure 5: Cross sectional view of the modified coupler (version B).

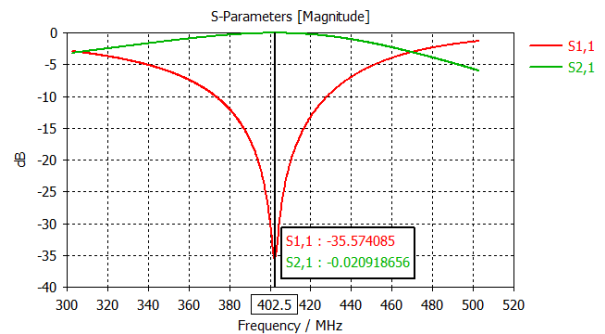

Figure 6: Frequency domain response of the coupler after optimization (version B).

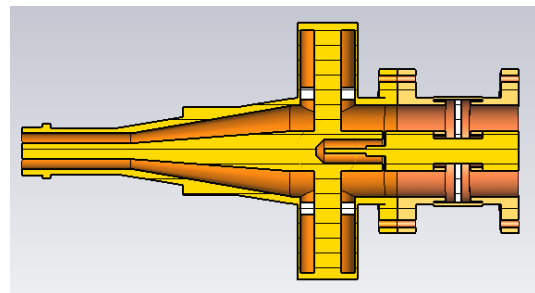

Figure 7: Cross sectional view of the modified coupler (version C).

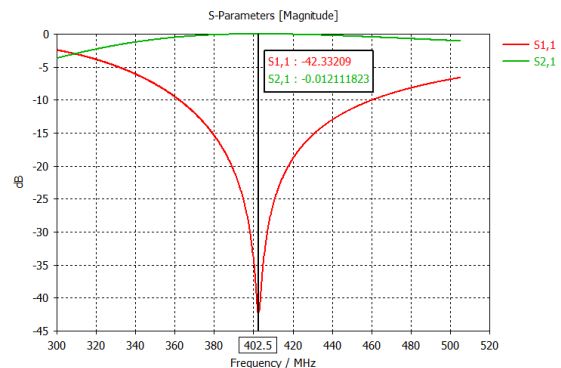

Figure 8: Frequency domain response of the coupler after optimization (version C).

Content from this work may be used under the terms of the CC BY 4.0 licence (© 2021). Any distribution of this work must maintain attribution to the author(s), title of the work, publisher, and DOI

## MULTIPLICATION CONSIDERATION

The DC isolation achieved with the three design iterations could be used to provide increased multipacting suppression. Since multipacting is a relatively low energy phenomenon, a certain DC voltage level could be used to increase electron energies in the structure. This would bias electron energies to secondary electron yield (SEY) curve positions with lower multipacting probabilities, thereby reducing multipacting activities [4, 5].

## THERMO-MECHANICAL ANALYSIS

When the RF power passes through the coupler, the dielectric loss of ceramic and Joule loss on the surfaces will cause the temperature to rise. As a result, the material will deform, and thermal stresses will be generated.

In the following, thermo-mechanical simulations were performed with ANSYS Mechanical. The material properties used are listed in Table 1. The following boundary conditions were used: connecting flange faces are at 22°C, connecting faces with the RFQ at 20°C, and the heat fluxes on the coupler surfaces are provided by the RF simulations for a power of 400 kW described previously.

Table 1: Material Properties used for the Thermo-mechanical Simulations

Material	Alumina	Copper C10100
Elastic Modulus (Pa)	$2.459 \times 10^{11}$	$1.26 \times 10^{11}$
Poisson's ratio	0.2392	0.345
Density ( $\text{kg/m}^3$ )	3,475	8,942
Coefficient of thermal expansion ( $^{\circ}\text{C}^{-1}$ )	$9.042 \times 10^{-6}$	$1.674 \times 10^{-5}$
Thermal Conductivity ( $\text{W/m}^{\circ}\text{C}$ )	25	400

Figure 9 shows the temperature contours in the symmetry plane for versions B and C of the coupler. The presence of the ceramic around the conductor pin and the stub led to slightly higher temperatures in these regions since the ceramic conducts heat better than vacuum. Using the temperature distribution, a structural analysis is performed adding the gravity force and the atmospheric pressure on the outside. For both versions, the highest stress is found in the ceramic parts on the stub at about 130 MPa, which is much lower than the tensile yield strength of the ceramic (200-300 MPa). The highest stress in the copper is about 109 MPa and 60 MPa in versions B and C respectively (Fig. 10), which is much lower than the tensile yield strength for a C10100 bar (275 MPa). Thus, the analysis suggests that the design is mechanically safe for operation at 400 kW.

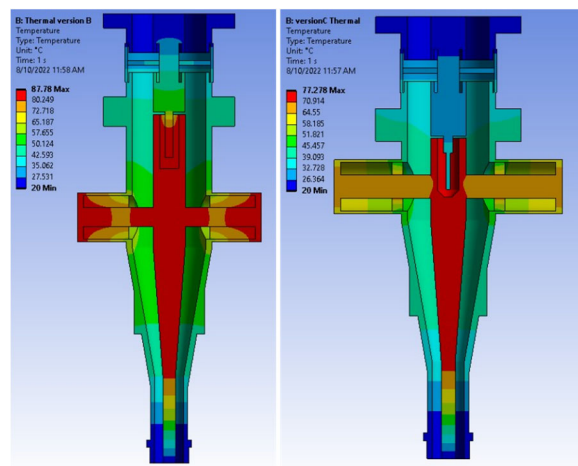

Figure 9: Temperature contours in the symmetry plane for the coupler version B (left) and C (right).

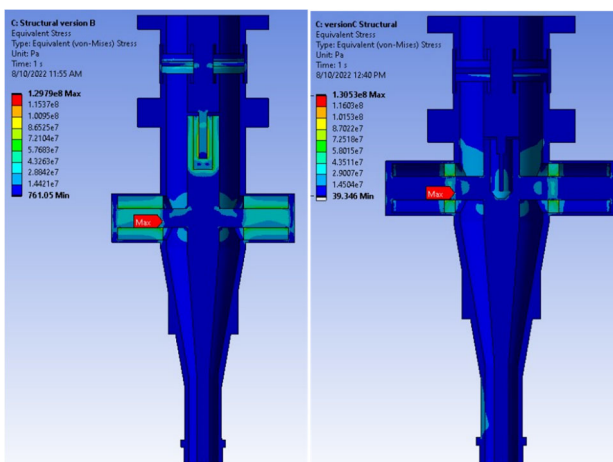

Figure 10: Thermal stress distribution for the coupler version B (left) and C (right).

## SUMMARY

An ongoing project at the SNS seeks to improve the electrical and mechanical performance of the RFQ couplers. To support improved operational availability and reliability, RF and Mechanical engineers developed a new coupler design with the goal to reduce machine downtime associated with maintenance activities, repairs, and upgrades. The design separates the coupler into two subassemblies and maintains fixed coupling with the RFQ. Simulation results showed strong RF and mechanical capabilities. Additional cooling and ceramic surface treatment options are being considered for the prototype fabrication.

## ACKNOWLEDGEMENTS

The authors of this paper would like to acknowledge Mr. Timothy Miner, Mr. Mark Cardinal, and Mr. Robert Peglow for their help on this project.

## REFERENCES

- [1] S. Kim *et al.*, “Stabilized operation of the Spallation Neutron Source radio-frequency quadrupole”, *Phys. Rev. Spec. Top. Accel. Beams*, vol. 13, p. 070101, 2010.  
doi: 10.1103/PhysRevSTAB.13.070101
- [2] Y. W. Kang *et al.*, “Upgrade of Input Power Coupling System for the SNS RFQ”, in *Proc. EPAC’08*, Genoa, Italy, Jun. 2008, paper MOPP091, pp. 763-765.
- [3] Y. W. Kang *et al.*, “Design and high power processing of RFQ input power couplers”, in *Proc. PAC’07*, Albuquerque, NM, USA, Jun. 2007, WEPMS074, pp. 2505-2507.  
doi: 10.1109/PAC.2007.4441298
- [4] P. Goudket, “A Study of Multipacting in Rectangular Waveguide Geometries”, Ph.D dissertation, College of Science and Technology, Lancaster Univ., England, 2004.
- [5] N. Hilleret, “Surface Properties of Technological Materials and their Influence on the Operation and Conditioning of R.F. Coupler,” CERN-LHC/VAC, 2002.