

REAL-TIME MOTOR CONTROL SYSTEM FOR BEAMLINES

Chia-Feng Chang, NSRRC, 101 Hsin-Ann Road, Hsinchu 300, Taiwan

Abstract

To improve the stability and accuracy of motor control system for Beamline, the beamline with motor adjustment mechanism collocates with the real-time firmware motor control system through the high-definition motor mechanism. Because the real-time motor control system doesn't need to be connected with the computer for a long time, it improves the speed, stability and accuracy of closed loop operation thus promote the controlling ability of motor. As a result, the real-time motor control system will improve the stability and accuracy of the entire motor control system with beamline.

INTRODUCTION

Closed-loop control is a vital part of a control system. The parameters of closed-loop control and the advantage and disadvantage of an analog input/output system will lay influence on the control system results. This text is designed to discuss about the applications for Closed-loop control and analog input/output system, in order to enhance the stability and accuracy of beamline motor control system. Consequently, we adopt analog input/output system, FPGA and closed-loop control for design.

Because the stepper motor equipped with a reducer can analyze mobile platform to 10 nanometers per stepper, with FPGA accompanied to simultaneously trigger the activation of an analog input/output system, the addition of a closed-loop control mode firmware into this hardware structure can enhance the stability of the beamline motor system, and the convenience of real-time adjustment against stability. Thus, the beamline control system will be about stability, accuracy and convenience.

SYSTEM ARCHITECTURE

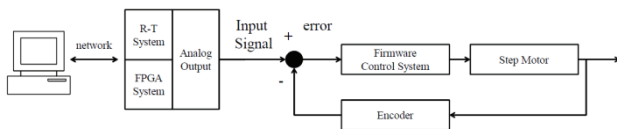

Figure 1: Close-loop Control architecture of Motor control system.

The control system structure in this text is designed by way of R-T closed-loop control (Fig. 1), with the analog input/output module acting as the reading and processing center, and FPGA module and firmware controllers acting as the hardware. The computer end serves to give location orders and besides, the stepper motor serves as the hardware of actual motion and the reading sensor serves to return its actual moving distance for the Encoder.

Control System Description

The hardware related to the control system in the text is composed of three portions: the first is, the computer-controlled center, including the PXI-8108 multi-core processor equipped with R-T module, the analog input/output module, FPGA module; the second is the firmware, the stepper motor control system, responsible for converting the analog output of the analog input/output module into digital forms, and use this data as motion signal; the third is Encoder, which will act according to the moving distance of motion signal after receiving that signal. The information on distance changes can be accessed the value of Encoder Count (Fig. 2).

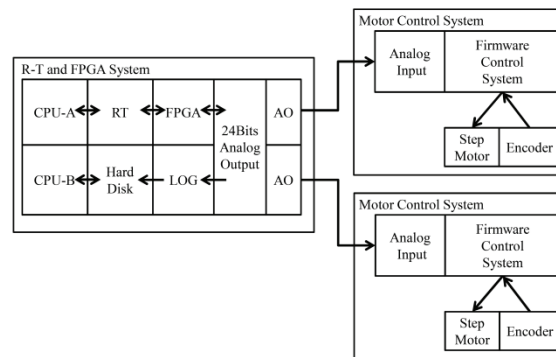

Figure 2: System architecture of R-T control system.

System Process Flow

After the system is activated, R-T System produces voltage signals by way of analog output module, and later synchronizes two sets of voltage signal through FPGA module, to avoid time errors of voltage signal. Then, the analog signals will be converted into digital ones by way of firmware. After signal processing and the user-set distance confirmed, the CPU will take the voltage signals under control, with these signals connected to the voltage input module of the motor-controlled system and the converted voltage signals for the stepper motor, at the same time the apparatus in cooperation will change the length. This way, we repeat the procedure and the closed loop control of the firmware system will continue modification of locations (Fig. 3).

Content from this work may be used under the terms of the CC BY 3.0 licence (© 2016). Any distribution of this work must maintain attribution to the author(s), title of the work, publisher, and DOI.

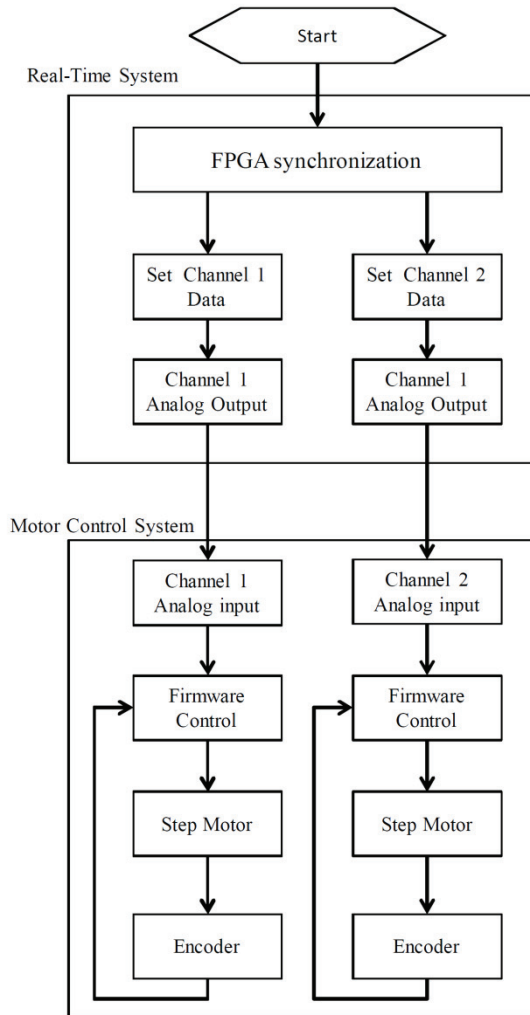

Figure 3: Flow chart of Motor control system.

HARDWARE DESCRIPTION

High-accuracy Data Acquisition Devices

The National Instruments 4461 is high-accuracy data acquisition devices specifically designed for sound and vibration applications. The devices include the hardware and software needed to make precision measurements with microphones, accelerometers, and other transducers that have very large dynamic ranges (Fig. 4).



Figure 4: The picture of high-accuracy data acquisition devices.

FPGA Technology

NI R Series multifunction RIO devices offer the best combination of value and performance by integrating this FPGA technology with eight analog inputs, eight analog outputs, and 96 digital I/O lines, all into a single device that is offered on standard PC form PXI, Using the LabVIEW FPGA Module (Fig. 5) [1-3].



Figure 5: The picture of FPGA Module.

PROGRAM INTERFACE

Program interface applies National Instruments LabVIEW as the layout. One can acquire system information from the graph, including Encoder, analog output waveform and set point information; moreover, the content of the program is composed of high resolution analog output module reading program, data storage, dual-core control and synchronize motion control program (Fig. 6).

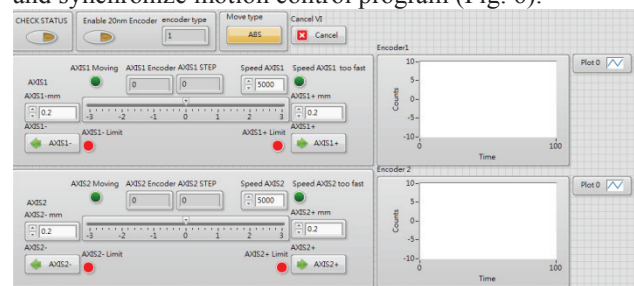

Figure 6: The visual Control interface.

FIRMWAVE CONTROL SYSTEM

To enhance stability and instantaneity, the integration of firmware's closed loop controls and motor controllers is used to maintain the accuracy of required locations through reduced time of communication with computers. In the following procedure of firmware's closed loop control, the required location is identified through analog output on the computer. While the location information required by controllers through analog input is digitized by way of the firmware program, the closed loop controlled module of the firmware system will initiate location modification. Since there's the farthest distance between the starting point and the targeted one, the enhanced motion distance will be the likewise farthest. The shorter motion distance is then used to make modifications. While the location is reached within the range of tolerable errors, the closed loop control will run into a status of placidity and the entire system will run stably. In this state of stability, if any displacement takes place, the system will move its structure to a correct position in order to lock in the location (Fig. 7).

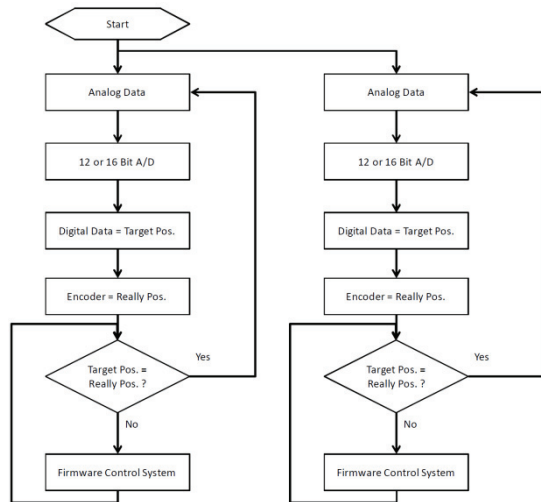

Figure 7: Flow chart of Firmware control system.

BEAMLINE APPLICATION

When the system has been applied into the slits of light beams, and at the same time when the computer has issued a motion order, with system parameters shown on Form 1, each axis will move in the meantime. Although the targeted distance set up by each axis differs, and because of the FPGA multi-tasking, the adjustments of each axis are made at the same time curves rather than at multi-stepping curves. Aside from the time differences, real-time modification can be made.

CONCLUSION

The FPGA hardware module can trigger signals activation and integrate with high-resolution analog input/output module to accompany R-T System, while the software applies the closed loop control module, which

can enhance the stability of stepper motor control to a 10-nanometer level. Consequently, the system can effectively enhance the stability and convenience of beamline controlling, and the R-T-FPGA system can reduce signal error caused by deferred time and thus improve the real-time efficiency of signal process.

ACKNOWLEDGEMENT

We would like to thank the staffs at NSRRC, especially those in the Experimental Technique Group and Beamline Group, for assistance in this project.

REFERENCES

- [1] NI web page, <http://taiwan.ni.com>.
- [2] Automatic Control System, Benjamin C. Kuo, 1997.
- [3] An FPGA-based feedback control system that suppresses the nanoscale resonance, Proceedings of the MEDSI 2014 Conference, Chia-Feng Chang, Melbourne, Australia - October 2014.