

Content from this work may be used under the terms of the CC BY 3.0 licence (© 2018). Any distribution of this work must maintain attribution to the author(s), title of the work, publisher, and DOI.

LCLS PULSE SELECTOR, A MULTIFUNCTION SHUTTER FOR THE LCLS-I 120 Hz FEL

R. R. Armenta[†], E. Paiser

Linac Coherent Light Source, SLAC National Accelerator Laboratory, Menlo Park, USA

Abstract

The Linac Coherent Light Source (LCLS) Pulse Selector was designed to pick specific pulses and reduce the repetition rate of the 120Hz LCLS pulse train in support of widely diverse, user defined experiments. It utilizes two rotating parallel plates to alternately transmit and block pulses in a single sweeping motion. A conventional stepper motor connected to the plates provides the rotation. The key to the system is its sophisticated timing scheme. Each sweep of the shutter is synchronized (with a precise delay) with the event codes normally generated with each pulse for data acquisition use. This shutter system has the capability of reducing the repetition rate of the LCLS x-ray to any frequency less than or equal to 60Hz in order to select a single pulse of LCLS x-ray beam at 120Hz. Since its installation, the pulse selector has been used in numerous experiments with great success providing independent pulse selection to individual beamlines at the same time.

INTRODUCTION

The Pulse Selector was commissioned to provide the hard x-ray beamlines (XPP, XCS, CXI, MEC, and later, MFX) with the ability to control pulse delivery without having to change accelerator machine modes/parameters. The key requirements were that (in addition to being able to fully attenuate the beam) the selector had to provide three main functions:

1. Provide single pulse selection (Mode 1)
2. Allow for multiple (n) sequential pulse selection (Mode 2)
3. Reduce the repetition rate of the 120Hz LCLS beam to up to 30Hz (Mode 3)

Initially the concept was to create a device similar in design to chopper/picker systems integrated at other synchrotron and FEL facilities e.g. the systems described by Kudr et al. [1] and Cammarata et al. [2]. These systems typically have a rotating disk or other shape with multiple apertures.

Material Considerations*

The pulse selector is required to block a certain number of x-ray pulses, i.e. attenuate the beam by more than about 20 orders of magnitude in the LCLS hard x-ray energy range (4-25 keV). While the required attenuation can be easily reached with small material thicknesses of high Z

element containing materials, the short attenuation length in this material leads to the absorption of energy in a very small volume. Depending on the dose (energy per atom) the absorbed energy can be sufficient to melt and thereby damage the material. Melting doses for different elements are listed in the following Table.

Table 1: Melting Doses for Individual Elements

Element	Melting Dose / (eV / atom)
Al	0.186
W	1.2376
Si3N4	0.187
Co	0.554

The maximum FEL pulse energy to reach the damage dose depends on the beam size. From all hard x-ray hutches the beam size is smallest at XPP (500 um) and therefore the fluence is highest there.

The maximum pulse energy to reach the melting dose for W and Co, the main components in the stopper material selected for this application (WC/Co), is shown in Fig. 1 for the full energy range.

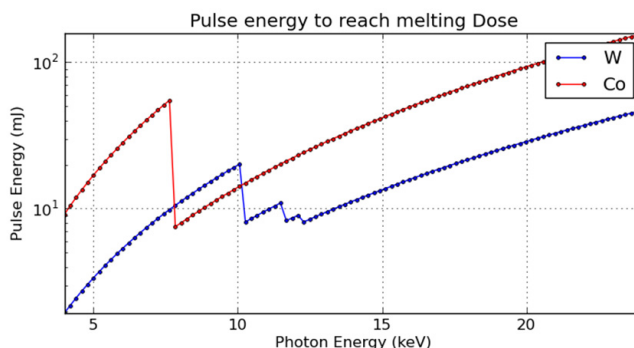

Figure 1: Pulse Energy to Reach Melting Dose.

Within the energy range of the first LCLS harmonic (4-10keV) damage might be reached. To prevent this, it was determined that coating with a lower Z material (Aluminum) would help for the following reasons: The x-ray pulse energy is reduced by attenuation in the coating material, and the material prevents melted material from leaving the x-ray exposed region. Coating of the stopper material with a metal would have been most preferable as it is mechanically very stable. However, when evaluating

[†] Contact: rebecca@slac.stanford.edu

* Material investigations performed by Henrik Lemke, LCLS staff scientist (2012)

the required thickness of the aluminium layer it was determined that 0.1mm was needed to increase the attenuation in the lower energy ranges (below 6 keV – where the material is most prone to beam damage).

DESIGN

Taking into consideration the requirement to layer the high Z tungsten carbide shutter material with at least 0.1mm of Aluminum, and the fact that 0.1mm is beyond the limitations of most conventional coating processes, it was determined that a separate layer of aluminum foil or sheet 0.02in thick (shown in Fig. 2) would be used in the assembly. This layering requirement limited the options for complex geometries such as disks with multiple channels or holes. As such, a simple parallel blade geometry was adopted. This geometry creates a single channel for the beam to pass through when aligned with the beam.

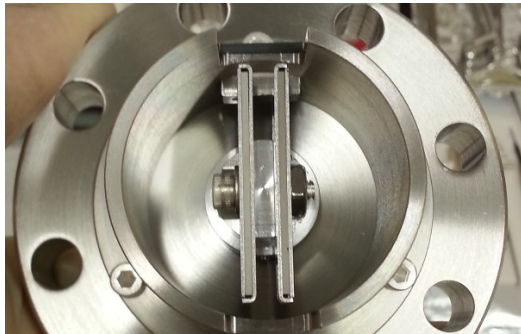

Figure 2: Parallel Layered Blades.

When clocked at a slight angle the blades block passage of the beam and when aligned with the beam allows it to pass through as shown in Fig. 3. With this simple mechanical concept methods to produce all three modes of operation were conceived.

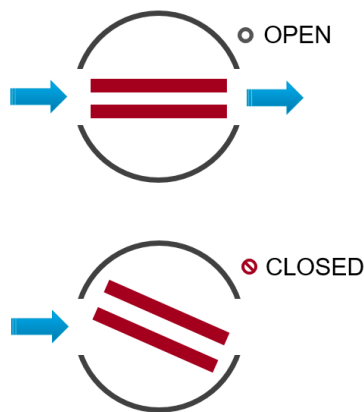

Figure 3: Opened and closed states of channel.

With only 8.3ms between pulses on the 120Hz LCLS beam the speed of the system opening and closing becomes an issue. Time taken for communication to the motor as

well as the time taken for blades to move into position easily add up to around 8-11ms. For the single pulse (Mode 1) and pulse rate reduction modes (Mode 3), in particular, the timing must be extremely efficient. To save time on each cycle in these modes the pulse selector sweeps through three states (closed-open-closed) in a single motion (and single command to motor). The timing of each sweep in alternate directions is synchronized and triggered by a simple pulse (the beamlines use the “Event Receiver” (EVR) to generate it). This concept is illustrated in Fig. 4.

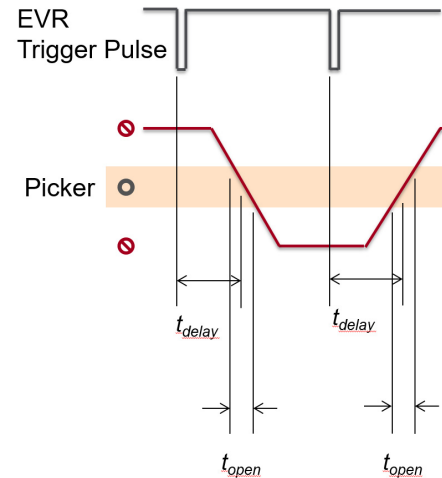

Figure 4: Open/Close cycle during a pulse rate reduction sequence (each swipe triggered by EVR Pulse).

Significant testing was performed in the lab (with offline pulses) during the conceptual design phase of the project in order to optimize the speed and tune the timing of the system. Variables such as sweep angle, motor speed/acceleration (and other parameters), gap length between blades, length of blades, trigger delay, and others were tuned to produce a robustly functioning shutter system before integration into the final mechanical system.

Mechanical

The Pulse Selector device is installed on each of the hard x-ray beamlines and shares a chamber with the hard x-ray attenuator assembly. The interface on this chamber for this device is a single 6.0 inch conflate flange. Each of the hard x-ray beamlines operate nominally at 10⁻⁷ scale vacuum in the areas in which these devices are installed.

Rotary Vacuum Feedthrough The rotation feedthrough chosen for this application is a ferrofluidic seal, so chosen because of its ability to transmit high speed rotation at this vacuum level (much testing was performed in the lab on this device pre-final design as well, testing off-gassing rates at speed as well as temperature effects on off-gassing). Although some hydrocarbons are released during continuous rotation of the seal, the levels do not exceed what can be tolerated in the zones in which these

Content from this work may be used under the terms of the CC BY 3.0 licence (© 2018). Any distribution of this work must maintain attribution to the author(s), title of the work, publisher, and DOI.

devices are installed (for example there are no precision optics nearby). In order to position the rotational bearings within the ferrofluidic seal as close to the blades as possible the seal is mounted in a re-entrant (inverted) bellows flange. This flange can be precisely positioned by an X/Y stage which the external device structure is mounted. The structure also provides support for the stepper motor and related components.

Stepper Motor The driving motor chosen for this system is an IMS Smart Motor [3], which is a stepper motor with integrated driver and controller. These are commonly used along the beamline at LCLS and have existing accommodations in the controls system infrastructure. But most importantly the on-board controller with this particular motor system has the built-in ability to accept fast trigger pulses, which was exactly what we needed to synchronize the shutter to the FEL pulses. To operate at the speeds necessary for this application the motor needs to be powered with a 60V power supply. After several hours of continuous operation, the motor has a tendency to get quite hot. A fan is necessary to keep it within safe operating temperature.

Blade Assembly The parallel blade assembly is mechanically fastened together onto a hub and secured to the ferrofluidic feed-through shaft of the vacuum side of the re-entrant flange. To remain secure during cyclical/high vibration operation conditions, the assembly utilizes deformable locknuts and spring pins to ensure a secure connection.

Other Features The system includes a high resolution optical rotary en-coder with reference mark used for motor positioning and homing. This is mounted on the air side of the rotary feed-through assembly. High precision limit/position switches enable precise positioning of the X/Y stages used for blade alignment. These features can be seen in Fig. 5.

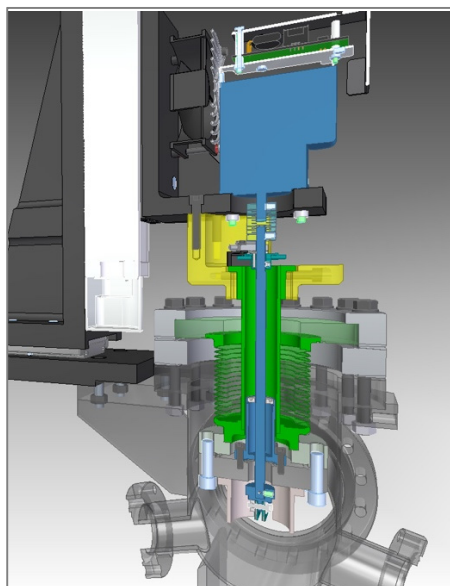

Figure 5: Cross section of Pulse Selector Device.

Controls

Using the IMS smart motors was deemed the simplest way to control the motor during design conception, but one of the big challenges during commissioning was to produce a very efficient program that, when integrated within the LCLS beamline framework, could read the EVR trigger and move the motor fast enough to accomplish single pulse selection and 30Hz (or higher) pulse rate reduction (the most difficult cases). During commissioning, the code developed during testing was refined and optimized for fast control with reduced overhead processing times. User interfaces and commands were developed for control of this device through the beamline control system.

The main beamline framework at LCLS is EPICS. Control of the Pulse Selector system is made by channel access (CA) process variables (PVs) via a Python command line (like SPEC) or through a Graphical User Interface (GUI). A dedicated GUI (referred to as EDM at LCLS) was developed for this device to select the mode of operation and to set specific motor parameters for the desired mode (if settings other than the default are desired). Alignment in X and Y directions and homing operations can also be performed from this interface.

The Pulse Selector IOC (input output control) program (EPICS software running on a generic server/computer) is used to communicate with the motor electronics sending the parameters necessary to set the mode of operation (single pulse, multiple sequential pulses, or pulse rate reduction) by serial line through a terminal server. The main program with different modes of operation is uploaded to the motor controller firmware and stored in their non-volatile memory by the IOC program only once. This allows for efficient execution of a program when the motor receives triggers.

The Pulse Selector timing configuration is done through the Event Sequencer. The Event Sequencer is a kind of command sequencer of operations that the scientists program prior to acquiring data. The output signal (Trigger) is issued after the selected timing events arrive in the EVR (Event Receiver) electronic board according to a particular set of events pre-programmed in the sequencer. A schematic for this process is shown in Fig. 6.

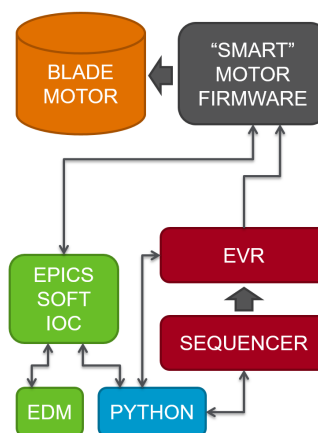

Figure 6: Motor Control System Schematic.

RESULTS

The Pulse Selector was installed and commissioned in 2013 in four hard x-ray beamlines at LCLS (XPP, XCS, CXI (two are installed at CXI), MEC) and has been running consistently ever since, with minimal required maintenance. In 2015 another unit was installed in the new hard x-ray endstation, MFX. The layout of the LCLS endstations (instruments) are shown in Fig. 7.

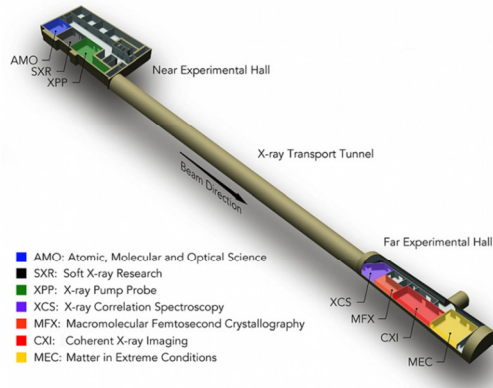

Figure 7: LCLS Instrument Map.

The Pulse Selector is typically used when running detectors that operate with readout rates lower than 120Hz as well as for alignment and detector tuning. For most beamlines this means 10-30% of the time. For MEC, an endstation that mainly runs single shot experiments, the Pulse Selector is used 100% of the time. For single shot experiment like MEC, i.e. one shot every few minutes, or low rate experiment at 10Hz, 30Hz, it allows the accelerator to run at its maximum rate (120Hz) where feedback and diagnostics are optimized to provide best stability. Additionally, the Pulse Selector is an essential element in the multiplexing scenario, when two (or three) hutches are using the same beam, where it allows experiments to control the pulse rate delivered independently of each other.

CONCLUSION

The mechanics of the Pulse Selector system are simple and robust and are designed to specifically withstand the LCLS FEL beam. The motion and timing concepts were prototyped and perfected in the lab before being integrated into final mechanical form. During the commissioning period the system software was refined and tuned, providing reliable and efficient control. The system has been in operation for five years and has become an indispensable component of LCLS standard beamline instrumentation.

ACKNOWLEDGMENTS

We are grateful for our colleagues at SLAC National Accelerator Laboratory who contributed to this project's success: M. Campell, J. Delor - Mechanical Engineering concepts and testing; J. Ludvik, K. Gumerlock - Controls integration; H. Lemke, A. Robert - Scientific guidance and support.

REFERENCES

- [1] T. Kudo *et al.*, "Vacuum-compatible Pulse Selector for Free-Electron Laser", *Review of Scientific Instruments*, 80, 093301 (2009).
- [2] M. Cammarata *et al.*, "Chopper System for Time Resolved Experiments with Synchrotron Radiation", *Review of Scientific Instruments*, 80, 015101 (2009).
- [3] Schneider Electric MDrive Motors, <https://motion.schneider-electric.com/all-products/mdrive-intelligent-motors/mdrive-plus-products/>