

# MECHANICAL DESIGN OF A SOFT X-RAY BEAM POSITION MONITOR FOR THE COHERENT SOFT X-RAY SCATTERING BEAMLINE

C. Eng, D. Donetski<sup>1</sup>, J. Liu<sup>1</sup>, S. Hulbert, C. Mazzoli, B. Podobedov  
 Brookhaven National Laboratory (BNL), <sup>1</sup>Stony Brook University (SBU)

## Abstract

Achieving photon beam stability, a critical property of modern synchrotron beamlines, requires a means of high resolution, non-invasive photon beam position measurement. While such measurement techniques exist for hard x-ray beamlines, they have yet to be achieved for soft x-ray beamlines. A new soft X-ray beam position monitor (SXBPM) design based on GaAs detector arrays is being developed and will be installed in the first optical enclosure of the Coherent Soft X-ray Scattering (CSX) beamline at the National Synchrotron Light Source II (NSLS-II).

The SXBPM assembly contains four water-cooled blade assemblies, each of which will have a GaAs detector assembly mounted within it, that can be inserted into the outer edges of the CSX undulator beam with sub-micron accuracy and resolution. The primary challenges in design of the SXBPM include: 1) mechanical stability of the assembly, 2) management of the heat load from the undulator x-ray beam to protect GaAs detector assemblies from unwanted illumination, 3) assembly compactness to fit within the first optical enclosure (FOE) of the CSX beamline, and 4) accessibility for modifications. Balancing the unique design requirements of the SXBPM along with their associated constraints has resulted in the design of a non-invasive beam position monitor which will be installed in the CSX FOE as a prototype for testing and iterative improvement. The ultimate goal is development of a widely useful SXBPM instrument for soft X-ray beamlines at high brightness synchrotron storage ring facilities worldwide.

## INTRODUCTION

Quality of data produced by the beamline is highly dependent on their soft x-ray beam control: both high positional beam stability and wavefront control are required at the sample position. In this respect, diagnostics such as Beam Position Monitors (BPMs) are a critical tool for evaluating and controlling photon beam delivered by modern highly coherent sources. Photoemission blade based BPMs work well for white beams of considerable power, while diamond x-ray BPS in transmissive geometry have proved effective for hard x-ray monochromatic beams. However, none of the above are ideal for soft coherent undulator sources, where a non-invasive device with high spatial resolution is needed. Stringent limitations come from intrinsic characteristics of the soft sources (halo extent, coherence of soft cone in the center of the undulator emission) and from the limited transmissive power of soft x-rays in materials.

Additionally, an optimal BPM design should permit positioning of the blades as far possible from the undulator central cone to preserve the wavefront coherence of the usable fraction of the beam. The BPM design described herein uses arrays of 1D strips of pixelated GaAs detectors mounted on adjustable blades that are inserted partially into the beam to intercept only the outer edge of the beam [1]. The SXBPM will be installed inside the FOE of the CSX beamline (Fig. 1) for ease of access to facilitate testing and development. Following commissioning and testing of this prototype, a subsequent “production” version is envisioned to be developed for placement in beamline front ends.

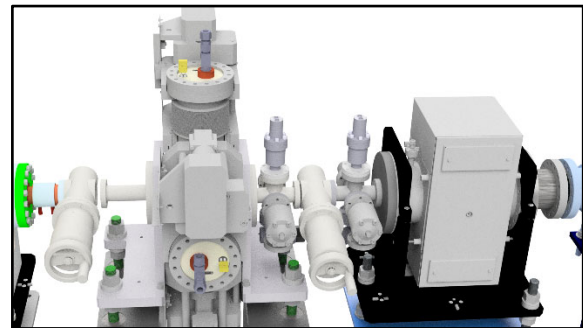

Figure 1: Rendering of the SXBPM installed in the CSX FOE as a separate section to facilitate replacement and reconfiguration of the detector assemblies.

## DESIGN REQUIREMENTS

The SXBPM’s primary function is to non-invasively monitor the position of the soft x-ray beam upstream of the first optics element using novel GaAs detector arrays. As a beam position monitor, the device must be stable and support sub-micron scale resolution positioning of the detector arrays, while providing a stroke/travel range sufficient to remove the detector arrays completely from the photon beam. Additionally, the SXBPM requires accessibility in order to facilitate reconfiguration or replacement of the detector arrays for testing (Fig. 2). The selected location for the SXBPM is upstream of the first optics element of the CSX (23-ID) beamline, necessitating careful consideration for handling the heat load.

## DESIGN OVERVIEW

The GaAs detector arrays will be mounted on the ends of 4 water-cooled blades consisting of OFHC copper. To protect the vulnerable parts of the detector arrays from excessive heating, a tungsten plate is mounted in front of each assembly. On the beam-facing edge of the tungsten plate, an array of laser-drilled 30 micron diameter holes

permit a limited amount of radiation to reach the detector (Fig. 3). A thermocouple will be affixed to the tungsten aperture plate to monitor the temperature of the device.

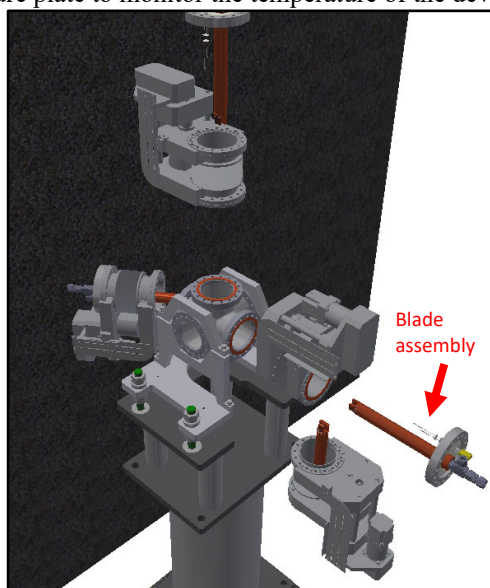

Figure 2: The SXBPM is designed to permit replacement, in-place, of each of the flange assemblies.

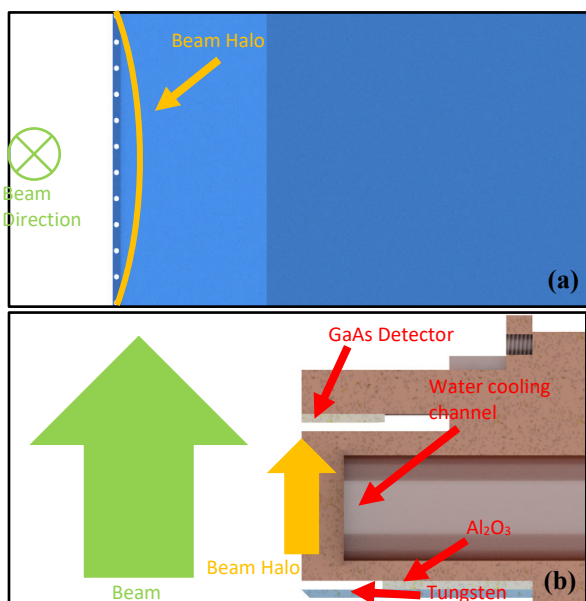

Figure 3: The tungsten heat shield, shown with the halo of the beam represented by the red line (a), is placed in front of an alumina (Al<sub>2</sub>O<sub>3</sub>) insulating element and the GaAs detector array (b).

The blade assembly is welded to a flange that also provides feedthroughs for cooling water and electrical connections for thermocouples and detector readout, forming a detector assembly. The four detector assemblies are mounted to bellows-coupled stepper-motor-driven linear manipulators, thus eliminating the need for relative motion of the components of each detector assembly internal to the vacuum vessel and obviating the need for any water connections in-vacuum. The linear manipulators enable sub-micron positioning of the detector arrays over a

25 mm travel range, permitting complete retraction of the detectors out of the beam (Fig. 4).

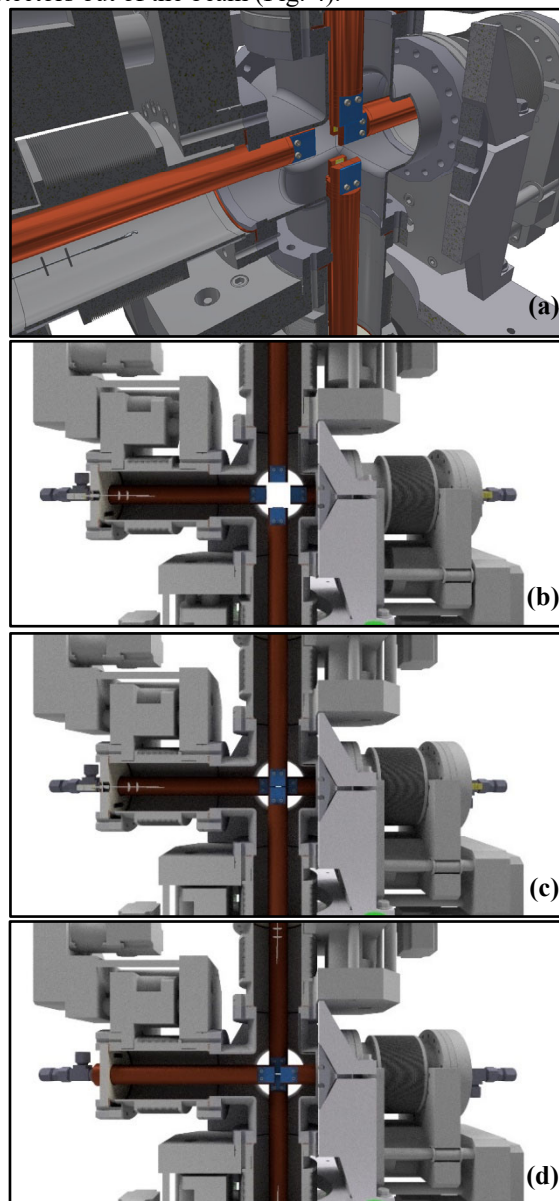

Figure 4: The SXBPM (a) consists of 4 separate blade flanges that can be extended into the beam and retracted out of the beam fully (viewed from the incoming beam direction) (b) and can be configured in either v-h configuration (vertical pair before horizontal pair) (c) or h-v configuration (d) by removing and repositioning the flange assemblies.

Simulations of the thermal load on the device are used to guide the design of the blade assemblies themselves (Fig. 5). Transient analysis is used to determine how quickly critical components of the detector, most notably the detector arrays themselves, reach maximum operating temperature under different conditions considering how much of the beam profile is intercepted. The maximum power density for the CSX undulator is approximately 20 W/mm<sup>2</sup>. However, the 23-ID canted straight section contains another identical undulator upstream. Therefore,

the worst-case scenario of approximately  $35 \text{ W/mm}^2$  is achieved for the inline configuration of two undulators, each set at the minimum gap. In addition to the intended sampling of the extreme edges of the beam, the worst-case scenario in which the blade intercepts the full beam profile (error condition), has been considered.

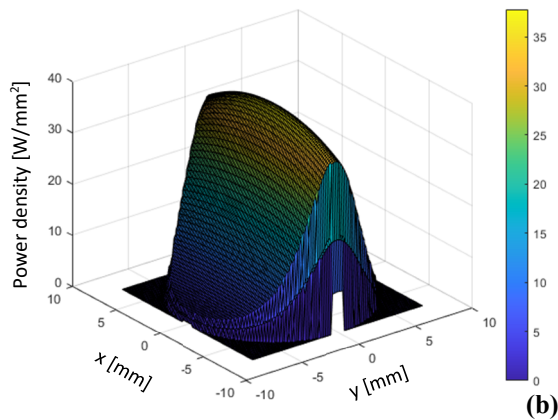
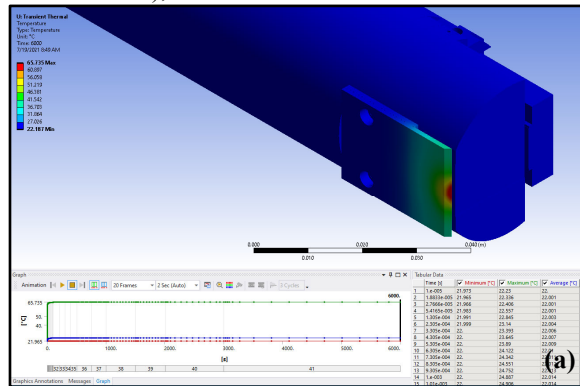

Figure 5: Design iterations are guided using thermal analysis (a) simulating thermal loading of the intercepted beam from the two undulators (b).

Operation of the SXBPM will consist of inserting the detector arrays into the halo of the beam while allowing unperturbed propagation of the soft part of the beam residing in the core, through to the beamline. The device will be integrated into the Equipment Protection System (EPS) to mitigate the possibility of intercepting full beam and consequent damage or destruction of the detector assembly via excessive thermal loading. Acceptable threshold values will be determined by thermal analysis which would trigger the retraction of the blade assemblies completely out of the beam. Additionally, a combination of mechanical hard stops, limits, and software controls will be used to monitor the position of the detector assemblies and prevent collisions.

## CONCLUSION

A GaAs detector based, non-invasive, sub-micron resolution soft x-ray BPM has been developed and will be installed and tested at the CSX beamline. Successful demonstration of the SXBPMs capabilities will pave the way for future installations at new and existing soft x-ray beamlines, especially for coherent soft x-ray beamlines.

## REFERENCES

- [1] J. Liu *et al.*, “Progress towards soft x-ray beam position monitor development”, in *Proc. IPAC’21*, Campinas, SP, Brazil, virtual conference, May 2021, paper MOPAB121, to be published.