

# Real-time Cavity Fault Prediction in CEBAF Using Deep Learning\*

Md. M. Rahman, K. Iftekharuddin, *Department of Electrical and Computer Engineering, Old Dominion University, Norfolk, Virginia 23529, USA*  
A. Carpenter, T. McGuckin, C. Tennant, L. Vidyaratne, *Thomas Jefferson National Accelerator Facility, Newport News, Virginia 23606, USA*

Data-driven prediction of future faults is a major research area for many industrial applications. In this work, we present a new procedure of real-time fault prediction for superconducting radio-frequency (SRF) cavities at the Continuous Electron Beam Accelerator Facility (CEBAF) using deep learning. We perform fault prediction using pre-fault RF signals from C100-type cryomodules. In our work, we propose a two-step fault prediction pipeline. In the first step, a model distinguishes between faulty and normal signals using a U-Net deep learning architecture. In the second step of the network, signals flagged as faulty by the first model are classified into one of seven fault types based on learned signatures in the data. Initial results show that our model can predict most fault types 200 ms before onset with reasonable accuracy.

\*This work is supported by the U.S. Department of Energy, Office of Science, Office of Nuclear Physics under Contract No. DE-AC05-06OR23177.

## Introduction

- CEBAF is a high power, continuous wave recirculating linear accelerator (linac) servicing four different experimental nuclear physics end stations [1]
- Energy upgraded from 6 GeV to 12 GeV in 2017 required the installation of 11 additional cryomodules [2]
- Each cryomodule is composed of 8 SRF cavities. The data acquisition system in CEBAF synchronously acquires timestamps and saves waveform records of 17 different RF signals from each cavity

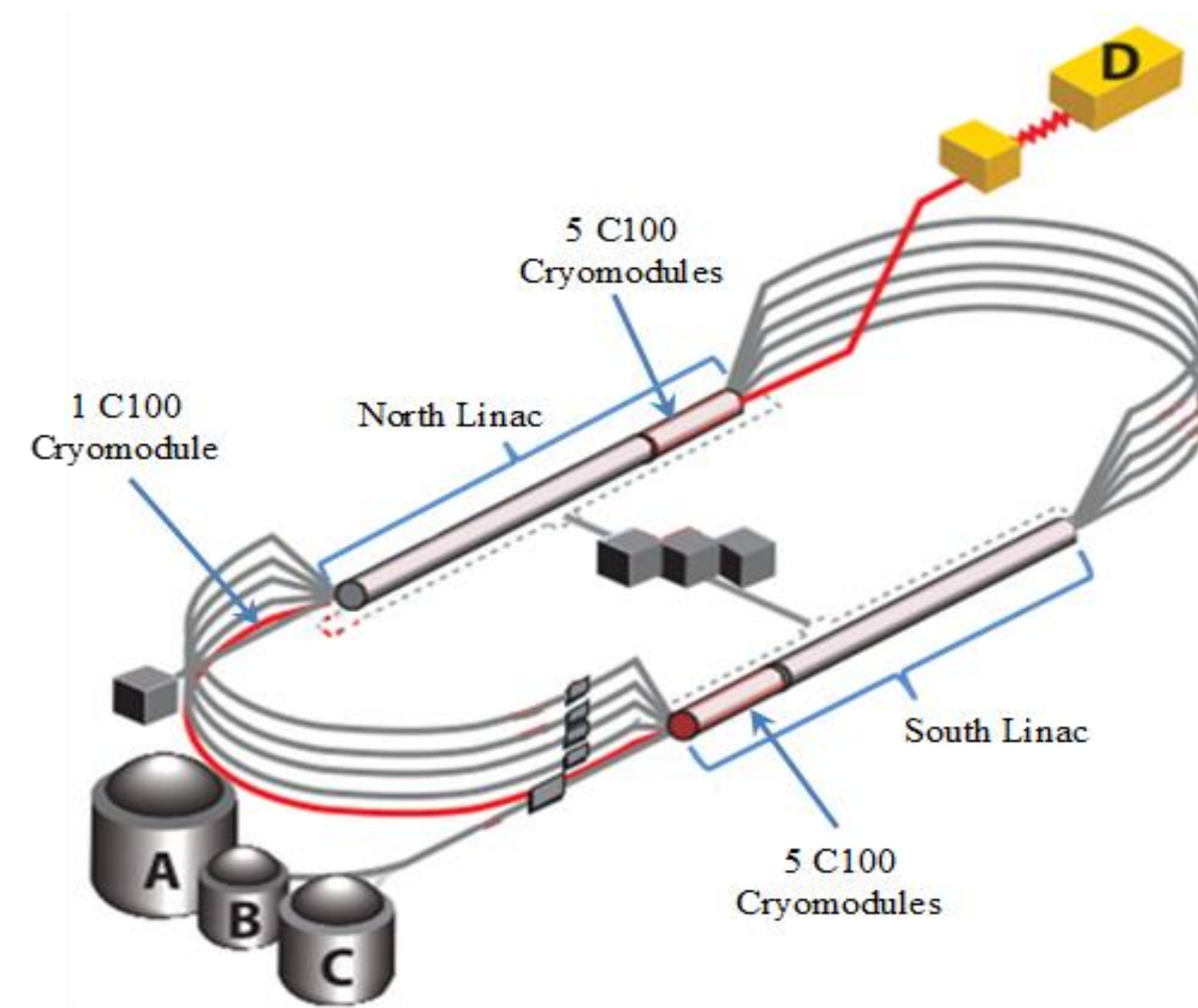

## Motivation

- CEBAF experiences frequent short machine downtime trips caused by numerous SRF system faults, especially when cavity gradients are being pushed to their limits
- Recorded waveform data are analysed by a subject matter expert (SME) to determine the cavity that caused the trip, and the type of fault – a time consuming and slow task
- Previous work successfully addressed this fault classification task with machine learning (ML) [3,4]
- In this work, our goal is to develop deep learning-based techniques to predict the fault before its onset
- The early prediction may enable potential mitigation strategies to prevent the fault

## Problem Definition

Predict different fault types *before* the fault onset using a two-step deep learning method

## Workflow

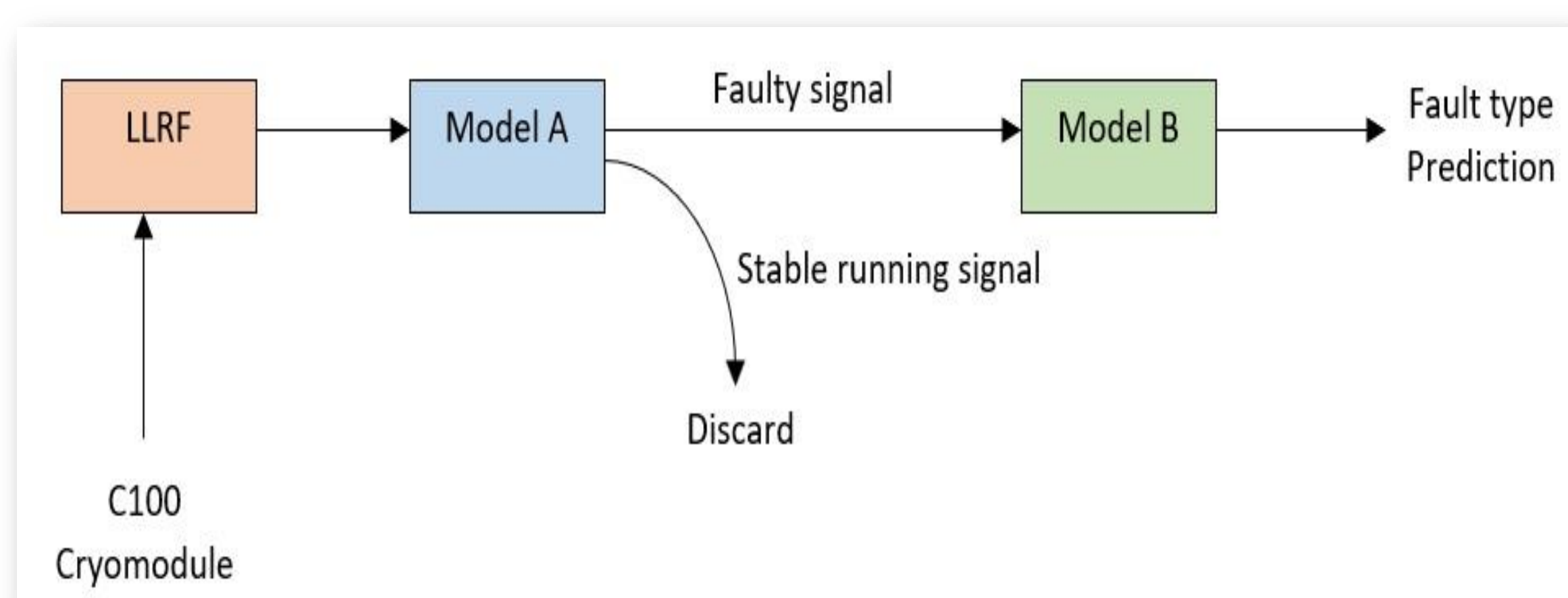

This work proposes a two-step pipeline to predict faults before their onset.

**Model A:** A binary classification network used to distinguish waveforms describing impending faults from stable signals

**Model B:** A multi-class classification network to predict the fault type, all before the fault onset

## Data

- The dataset used in this study is carefully collected from CEBAF operational runs using a data acquisition system installed at Jefferson Lab. The system records 17 different RF signals from each SRF cavity
- The duration of the recorded signals is approximately 1637.4 ms at a sample interval of 0.2 ms
- Two types of datasets used for this study: normal running, and faulty signals
- This work used 4 of the 17 recorded signals (GMES, GASK, CRFP, DETA2), identified by SMEs as having the greatest predictive power
- Each channel signal was standardized using min-max normalization which transforms signal values between 0 and 1.
- This experiment uses a time window of 100 ms

Table: Faulty Dataset Representation

Fault Type	# Of Events
100 ms quench	608
3 ms quench	541
electronic quench	674
microphonics	720
heat riser choke	709
control fault	848
single cavity turn off	883

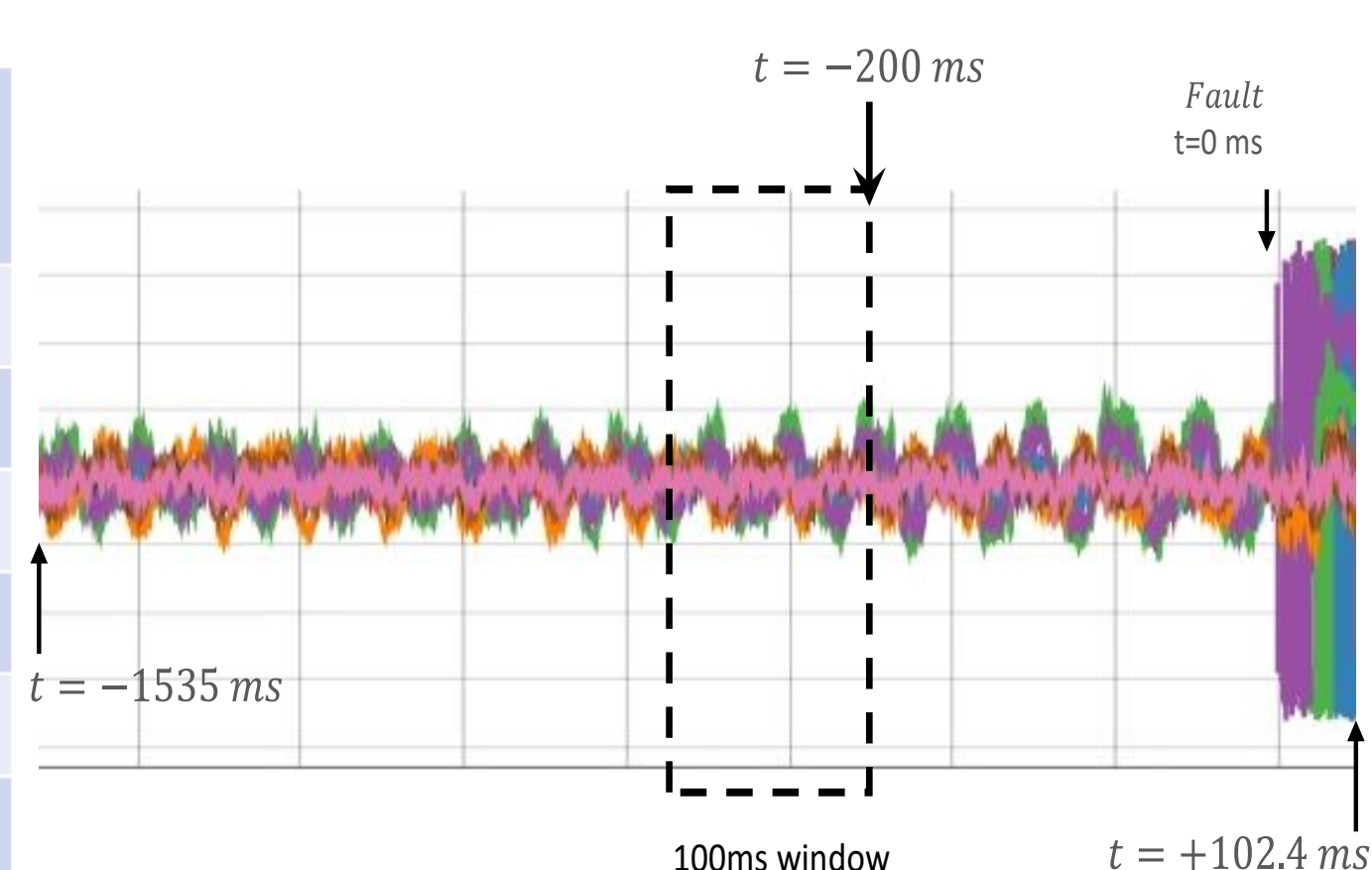

## Model A: Binary Classification

- Model A is a binary classifier that identifies waveforms describing impending faults
- A U-Net architecture is used to perform the binary classification
- The network is trained to reconstruct the input using normal running examples.
- Reconstructions with a higher mean square error (MSE) between input and output are considered a potential fault event
- We input 1994 test examples (fault examples were 200ms before onset) to the model from which 886 examples (with a threshold value of 0.030 for the MSE) were identified as impending faults. Among the 886 predicted impending faults, 600 cases were actual faults

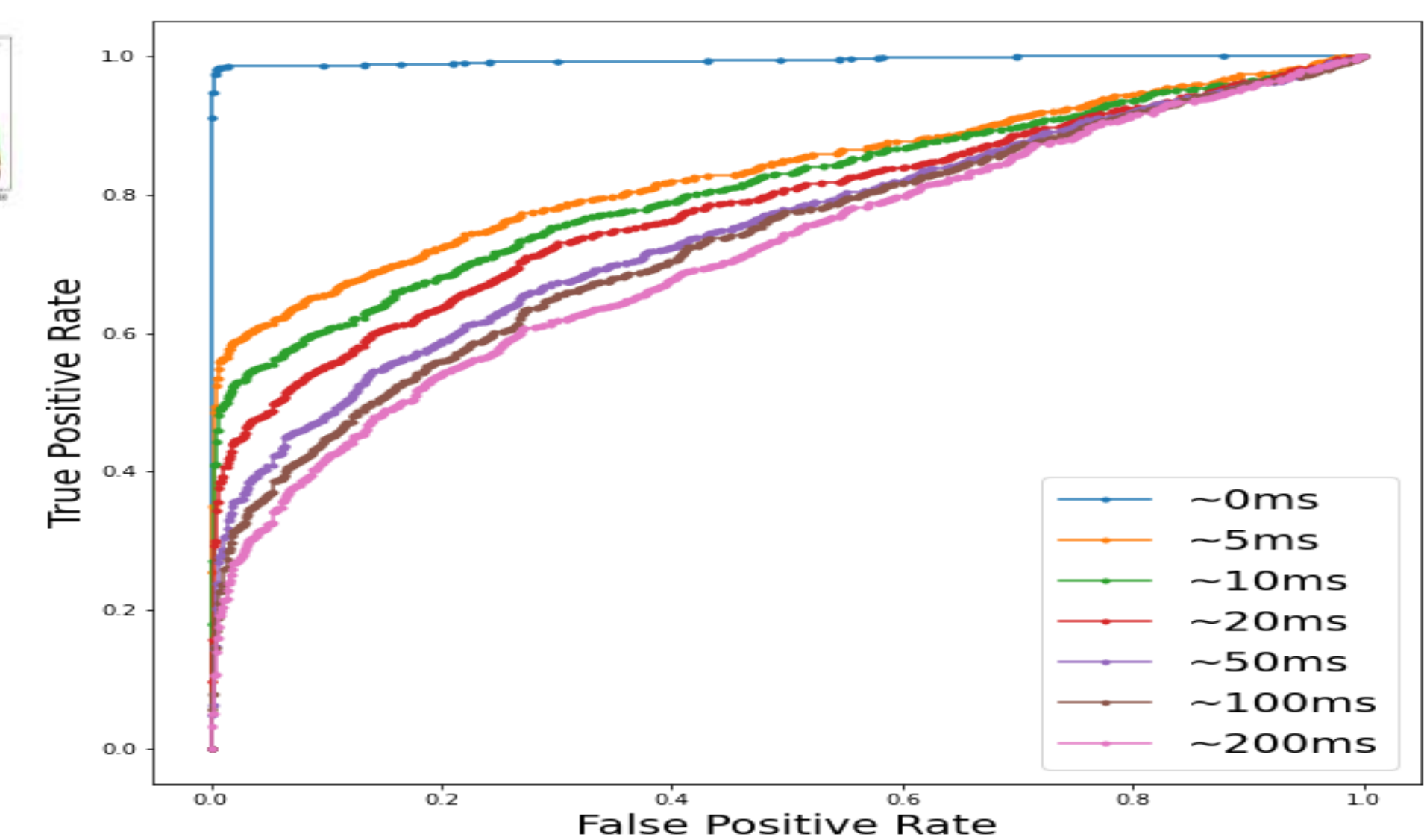
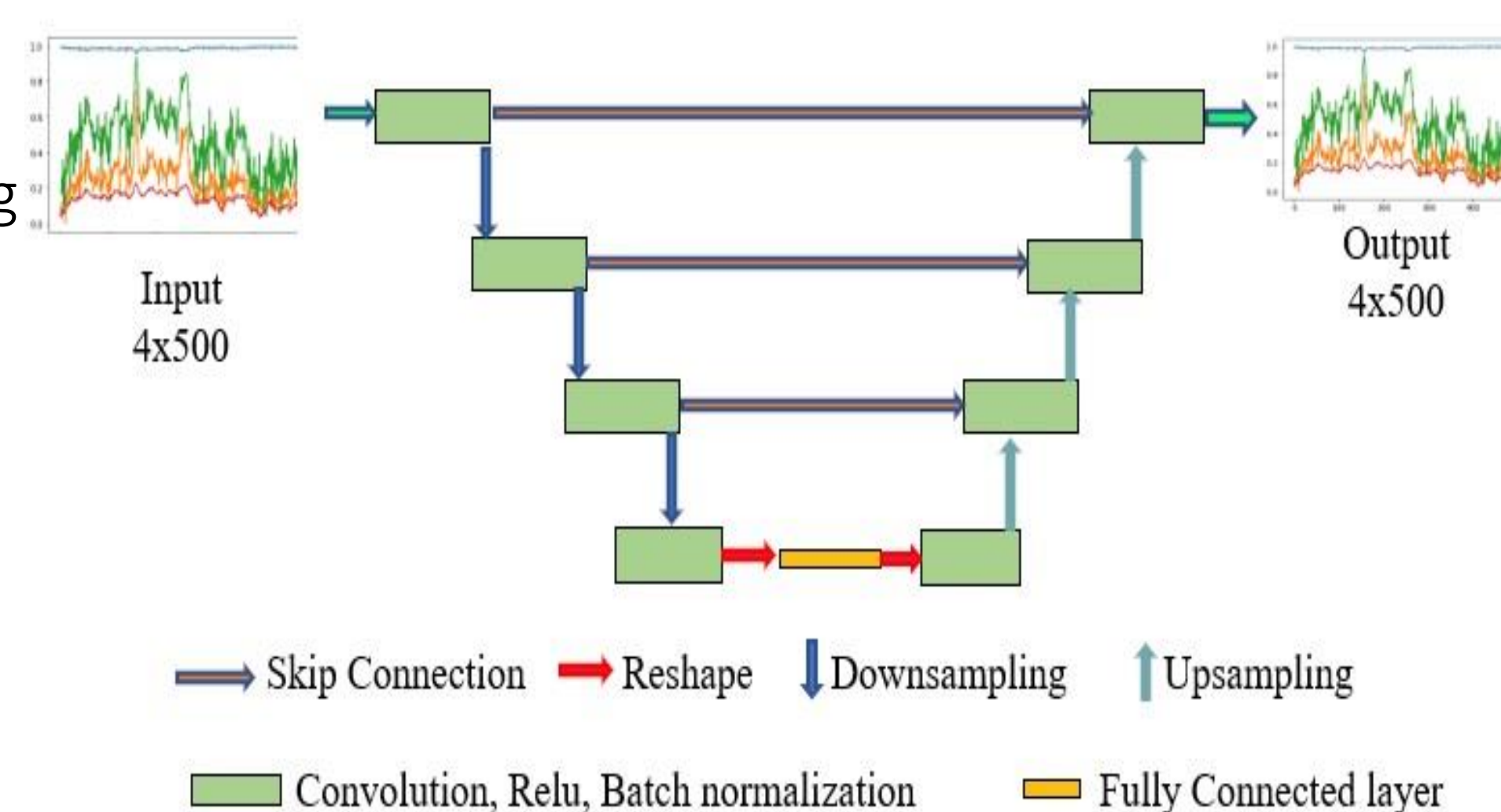

## Model B: Multi-Class Classification

- Model B is a multi-class classification model which is a combination of Long Short-Term Memory (LSTM) and Convolutional Neural Network (CNN)
- The output of this model contains 8 classes which include 7 different fault types and one class for normal signals
- The input of model B is the impending fault signal identified by model A
- The overall accuracy of the multi-class classification is 76.5% for predictions made 200 ms before the fault onset
- Slow-growing faults such as heat riser choke and microphonics showed higher f1-scores (87.3% and 83.3% respectively). Whereas some fast-growing faults such as 3ms quench and single cavity turn off showed lower f1-scores (45.9% and 47.2% respectively)

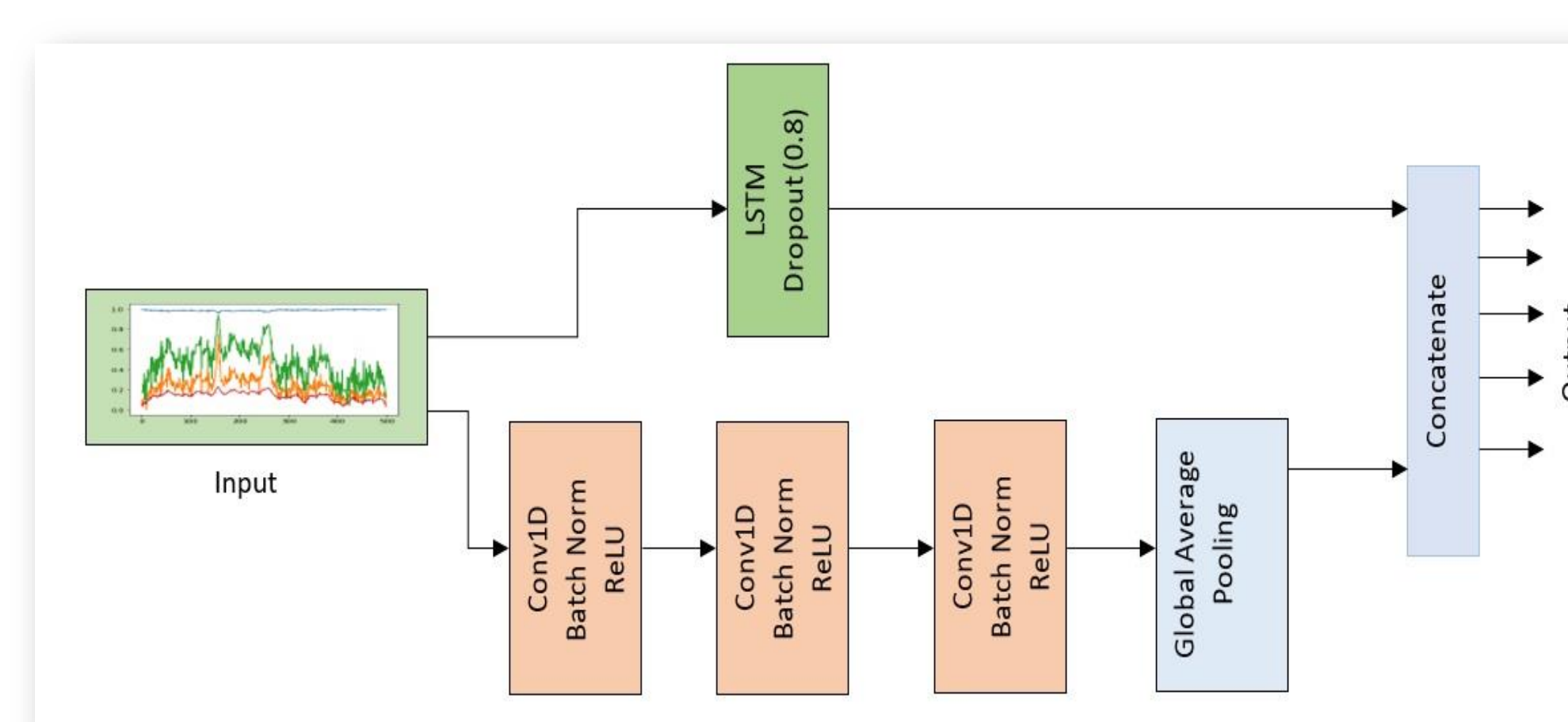

This label \ Predicted label	Quench100ms	Quench_3ms	E_Quench	Heat Riser Choke	Microphonics	Control Fault	Single Cav Turn off	Normal signal
Quench100ms	54	4	3	8	3	5	3	1
Quench_3ms	4	26	3	2	6	12	2	1
E_Quench	3	2	24	1	3	3	5	2
Heat Riser Choke	5	1	0	121	2	3	1	0
Microphonics	3	5	1	2	118	2	2	0
Control Fault	2	5	4	9	2	65	4	2
Single Cav Turn off	4	4	2	0	10	19	28	3
Normal signal	3	7	4	1	6	9	7	249

Overall accuracy=0.7654; misclass=0.2346

## Conclusion and Future Work

- Initial results show the model can predict the fault types 200 ms before the fault onset with reasonable accuracy
- The model shows good performance for slow-developing fault types while identifying fast-developing faults represents a challenge
- In the future, we will work to explore our ability to make system changes on timescales of a few hundred milliseconds to mitigate some of the faults that develop over a longer time, such as microphonics

## Acknowledgments

The authors would like to thank Tom Powers (Jefferson Lab) for his work in providing labeled data for this study.

## References

- C. Reece, "Continuous-wave superconducting radio frequency electron linac for nuclear physics research," *Physical Review Accelerators and Beams*, vol. 19, no. 12, p. 124801 (2016).
- L. Vidyaratne, A. Carpenter, R. Suleiman, C. Tennant, D. Turner, K. Iftekharuddin, and M. Rahman, "Initial studies of cavity fault prediction at Jefferson Laboratory", *18th Int. Conf. on Acc. and Large Exp. Physics Control Systems*.
- L. Vidyaratne, A. Carpenter, T. Powers, C. Tennant, K. Iftekharuddin, M. Rahman and A. Shabalina, "Deep Learning Based Superconducting Radio-Frequency Cavity Fault Classification at Jefferson Laboratory" *Front. Artif. Intell.* 4:718950 (2022).
- C. Tennant, A. Carpenter, T. Powers, A. Shabalina Solopova, L. Vidyaratne, and K. Iftekharuddin, "Superconducting radio-frequency cavity fault classification using machine learning at Jefferson Laboratory" *Phys. Rev. Accel. Beams* 23, 114601 (2020).