

RUNNING THE AGS MMPS AT 5 HZ, 24 GEV*

Ioannis Marneris, Thomas Roser, Alessandro G. Ruggiero, Jon Sandberg,
Brookhaven National Laboratory, UPTON, NY 11973, USA

Abstract

The Brookhaven Alternating Gradient Synchrotron (AGS) is a strong focusing accelerator which is used to accelerate protons and various heavy ion species to an equivalent proton energy of 29 GeV. At this energy, the maximum intensity achieved is 7×10^{13} protons per pulse. This corresponds to an average beam power of about 0.2 MW. Future programs in high-energy and neutron physics may require an upgrade of the AGS accelerator to an average beam power of around 4 MW, with proton beams at the energy of 24 GeV. This can be achieved with an increase of the beam intensity to 2×10^{14} protons per pulse that requires a 1.5-GeV super-conducting linac [1], as a new injector and by upgrading the power supply system to allow cycling at 5 beam pulses per second.

This paper describes the present mode of operation of the AGS main magnet power supply, the requirements for operation at 5 Hz and a proposed solution of all modifications required to upgrade the AGS main magnet power supply to operate at 5 HZ, with proton beams at the energy of 24 GeV.

1 PRESENT MODE OF OPERATION

The AGS Main Magnet Power Supply (MMPS) is a 6000 Amp, ± 9000 Volt Silicon Controlled Rectifier (SCR) power supply. A 9-MW Motor Generator, made by Siemens, is a part of the main magnet power supply of the accelerator, which allows to pulse the main magnets up to 50 MW electric peak power, while the input power of the motor generator remains constant. The maximum average power into the motor ever utilized is 7 MW, that is the maximum average power dissipated in the AGS magnets never exceeded 5 MW.

The AGS ring consists of 240 magnets hooked up in series. The total resistance R is 0.27 ohms and the total inductance L , is 0.78 henries. There are 12 super-periods, A through L, of 20 magnets each, divided in two identical sets of 10 magnets per super-period.

There are two stations of power supplies each capable of delivering up to 4500 Volt and 6000 Amp. The two stations are connected in series as shown in Figure 1, where the two magnet loads have a total resistance $R/2$ and a total inductance of $L/2$. The grounding of the power supply is done only in one place, in the middle of station 1 or 2 through a resistive network. With this grounding configuration, the maximum voltage to ground in the magnets will not exceed 2500 Volt. The magnets are hipped to 3000 Volt to ground, prior of each starting of the AGS MMPS after long maintenance periods.

Each of the two stations is composed of the F-bank and the P-bank power supplies in parallel. The F-bank power supply consists of 24 pulses (fundamental frequency 1440 Hz), ± 1900 Volt maximum, and 6000 Amp, and are used during the flat tops of the AGS cycles. The P-bank power supply consists of 12 pulses (fundamental frequency 720 Hz), ± 9000 Volt, and 6000 Amp, and are used during ramping up or down of the AGS cycles. This ensures minimum ripple during the flat tops, an essential condition for slowly extracted beam. However, there were still frequency components multiples of 60 Hz that needed to be reduced. An active filter was developed to reduce these frequencies. This was done by feeding these frequencies 180 degrees out of phase to a choke connected in series with the magnets of station 1, and by using a voltage regulated power supply. In addition to the active filter, there are two 300-Hz, 60-dB/decade passive filters to minimize voltage ripple of the AGS MMPS. SCR's and a set of fast and slow 95 switches are used to short stations 1 and 2 in case of a failure of the AGS MMPS, so that the energy stored in the AGS magnets decays with the $L/R = 2.8$ sec time constant

A typical magnet current with proton beams at the energy of 24 GeV, has a cycle period of 3.6 seconds long, including a 1.6-second flat-top and a 0.8-second front-porch. The acceleration or deceleration ramp lasts 0.6 seconds. The flat top current is close to 4200 amps. The peak power during acceleration is close to 30 MWatts. The average power dissipated in the AGS magnets for this pulse was estimated to be 2.8 MW.

2 FIVE-HZ MODE OF OPERATION

To cycle the AGS for the 24-GeV proton mode of operation at 5 pulses per second, the magnet peak current is 4200 Amp. Figures 3, 4 display the magnetic field, magnet current and voltage of a 5-Hz cycle. The cycle does not include a front-porch and a flat-top. Only single-turn extraction has been assumed. The magnet ramp, up and down, takes 0.1 second. The total average power dissipated in the AGS magnets is estimated to be 1.7 MW.

Figure 4 shows that one needs ± 37 kVolt across the whole magnet system. It was mentioned in section 1 that currently the maximum voltage to ground, the magnets see, is 2500 Volt maximum. Assuming that we are not going to redesign the AGS magnets, this constrain has to be followed in the new design of the AGS MMPS to run at 5 Hz.

* Worked performed under the auspices of the U.S.D.O.E.

3 PROPOSED SOLUTION

It is assumed that the existing ripple specifications are to be preserved, to run present flat top cycles and PPM modes as well as be able to run 5 Hz mode, in the future. To do this, and to limit the AGS coil voltage to ground to 2.5 kV the AGS magnets will need to be divided into eight identical sections, each powered similarly to the present half AGS power system, except that now the magnet loads is 1/8 of the total resistance and inductance. In this manner we will have eight identical P type stations of power supplies as one existing station and two F type stations, all hooked up in series as shown in Figure 2. Note that every P type station will be rated at +/-5000 volts 6000 Amps, the same as the present rating of the P type units. Bypass SCRs will be used across the 6 P type stations, to bypass these units during the flattops, for flat top modes of operation and ensure minimum ripple requirements. Note that only station 1 will be grounded as it is done presently. Using the configuration of figure 2, ensures that the maximum voltage to ground of every section of magnets will not exceed 2500 volts.

4 THE MOTOR GENERATOR

As one can see from Figure 4, the peak power required for a 5 HZ mode of operation, is approximately 160 MW. The existing motor generator cannot provide such a power swing, since it is rated at only 50 MW continues 95 MW pulsed for 1 sec. One needs to investigate if the upgrade can be done with a 200-MW generator or perhaps two 100-MW generators. It is convenient and maybe more economical that the motor generator(s) is of 6 or 12 phase to limit or even eliminate phase-shifting transformers so that every power supply system generates 24 pulses. For the case of a single generator if the generator is 6 phase the generator voltage would have to be around 15 kV line-to-line, generator so that the generator current is approximately equal to the magnet current during the time that the P-banks are turned on, as it is presently done. This needs to be evaluated if it technologically possible. If however two 100-MW generators are used, the output voltage would have to be 15 kV line-to-line for a 3 phase generator, or 7500 volts line-to-line, for a 6 phase one, to keep the generator and the magnet current approximately equal. Another specification of the motor generator is the 5 Hz frequency. That is, the generator is to be rated at a slip frequency of 5 HZ. One needs to investigate what is technologically possible, regarding these specifications and costs involved. Another approach is to use the existing motor generator and the rest of the power system for one quarter of the AGS ring, provided that it can indeed run at 5 HZ, and use another motor generator rated at 150 MW with a voltage 12 kV line-to-line, 6 phase, for the other three quarters of the AGS ring.

5 CONTROL SYSTEM

The control system of each eighth of the AGS ring upgraded power supply is very similar to the existing control system for the MMPS. There will be a voltage

regulator for every P type power supply referenced in Figure 1. As a result there will be 8 P type voltage regulators, 2 F type voltage regulators. There will also be a current regulating system as the outer loop of all eight voltage loops. All voltage references would be derived from the same MMPS computer program, except that they will be divided by 8. However, the current reference will be exactly the same as utilized currently. Note that the AGS MMPS computer program deriving these references, will be modified, to turn on, or off the bypass SCRs, based on maximum magnet voltage required. If we need to run present modes of operation with cycles requiring a flat tap, all bypass SCR's will be turned on and the power supplies which do not have bypass SCR's will be operated, the same way they are operated presently.

An issue to pay attention in more detail is the bandwidth of the voltage and current loop. The current loop must be 6 times faster than the present one, and a bandwidth of at least 10 to 20 Hz may be required. A bandwidth of 70 to 100 Hz should be sufficient for the voltage loops. Note that the present voltage loop bandwidth is 70 Hz.

The interlock system of every additional P type power supply will be very similar as the existing interlock system for the MMPS, which uses a programmable logic controller PLC system.

6 OTHER POWER SUPPLY CONCERNS

6.1 Eddy Currents

Running the AGS at 5 Hz requires that the acceleration ramp period decreases from 0.6 sec down to 0.1 sec. That is, the magnet current variation di/dt is 6 times larger than the present rate. Eddy-current losses on the vacuum chamber are proportional to the square of di/dt , that is 36 time larger than with the present mode of operation. Also, it is expected that the Eddy-current will alter the quantity and the quality of the magnetic field of the magnets during acceleration by 2 to 3%.

6.2 Real Estate

The new motor generator/generators and power supplies are to be housed in new buildings. The motor generator/generators will be located in one central building. Additional space is needed to house the new P type power supplies and their transformers. The construction, acquisition and location of new buildings may be problematic considering the limitation of the available real estate. This needs to be evaluated in more detail.

6.3 Mechanical stresses

As previously mentioned the assumption is that the main magnets will not be replaced. Pulsing the main magnets at 5 Hz will stress them mechanically. We need to evaluate the mechanical lay out of the magnets and bus associated and determine possible problems and solution of them.

7 CONCLUSION

We have determined, during this preliminary study, that the upgrade of the AGS accelerator facility to operate at the rate of five beam pulses per second is certainly feasible. We have outlined an approach to modify and to add to the present power supply system. One needs to expand and acquire a new motor generator. One needs to divide the AGS magnet ring in eight sections each connected to a power supply system as referenced in figure 1. We have also reviewed preliminary the performance of other accelerator systems that require attention for the proper operation at the new acceleration rate.

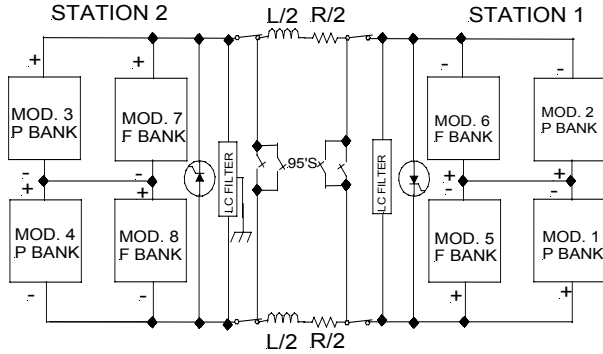

Figure 1: Present AGS Magnet Power Supply Configuration.

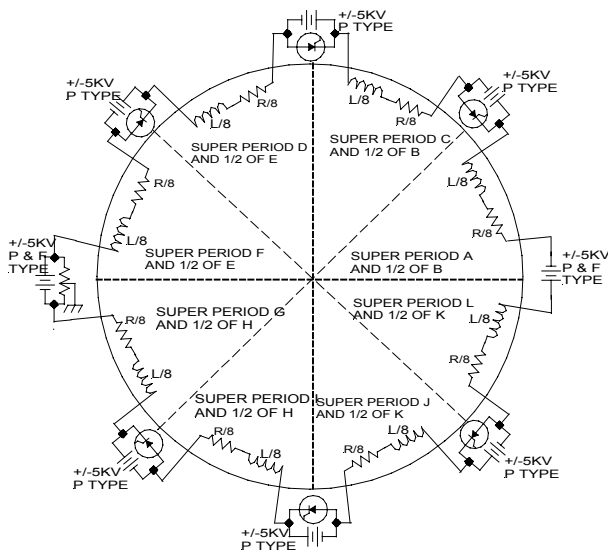

Figure 2. Modified AGS Power Supply Configuration for the 5-Hz mode of operation.

8 ACKNOWLEDGMENTS

The authors wish to thank A. Soukas, V. Badea, R. Bonati, for their engineering support.

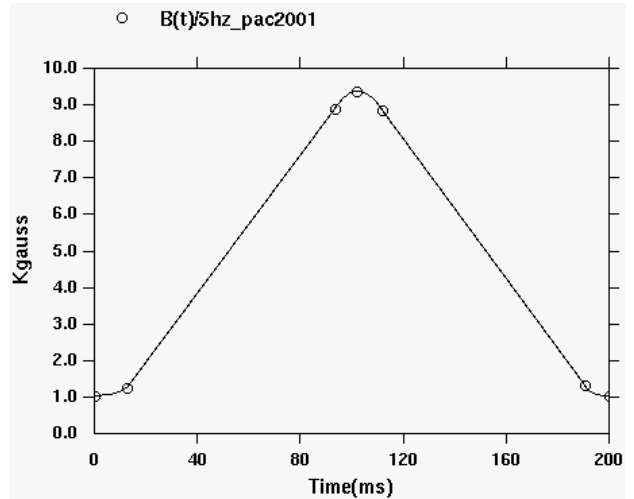

Figure 3. Magnetic field for the 5-Hz mode of operation.

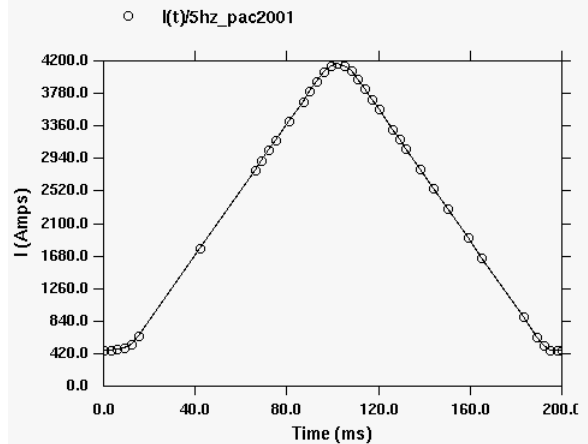
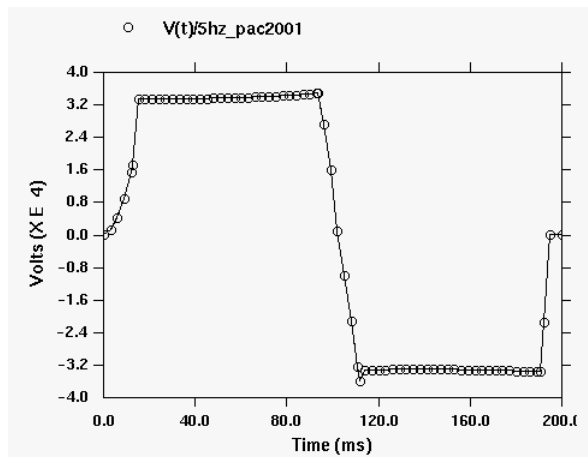

Figure 4. AGS magnet voltage and current for the 5-Hz mode of operation.

9 REFERENCES

[1] M.J. Brennan et al., "Upgrading the AGS to 1-MW proton beam power", these proceedings