

# FIRST HIGH-POWER EXPERIMENTS ON A TWO-CHANNEL X-BAND ACTIVE RF PULSE COMPRESSOR\*

A. L. Vikharev,<sup>1,2</sup> O. A. Ivanov,<sup>1,2</sup> A. M. Gorbachev,<sup>1,2</sup> V. A. Isaev,<sup>1,2</sup> S. V. Kuzikov,<sup>1,2</sup>  
 S. H. Gold,<sup>3</sup> A. K. Kinhead,<sup>4</sup> O. A. Nezhevenko,<sup>1</sup> and J. L. Hirshfield<sup>1,5</sup>

<sup>1</sup>Omega-P, Inc., New Haven, CT 06511

<sup>2</sup>Institute of Applied Physics, Nizhny Novgorod, 603600 Russia

<sup>3</sup>Plasma Physics Division, Naval Research Laboratory, Washington, DC 20375

<sup>4</sup>LET Corporation, Washington, DC 20007

<sup>5</sup>Physics Department, Yale University, New Haven, CT 06511

## Abstract

A brief report is presented on experiments carried out at the NRL X-band magnicon facility on a two-channel X-band active rf pulse compressor that employs plasma switches. Experimental evidence is shown to validate the basic goals of the project, which include: simultaneous firing of plasma switches in both channels of the rf circuit, operation of quasi-optical 3-dB hybrid directional coupler, coherent superposition of rf compressed pulses from both channels, and operation of the X-band magnicon directly into the rf pulse compressor. For incident 1.2  $\mu$ sec pulses in the range 0.63-1.35 MW, compressed pulses of 5.7-11.3 MW were obtained, corresponding to power gain ratios of 8.3-9.3. Insufficient bakeout and conditioning of the high-power rf circuit prevented experiments from being conducted at higher rf input power levels.

## INTRODUCTION

Active rf pulse compressors are nowadays commanding interest for use in a future electron-positron collider [1,2]. Here, results are given of the first high-power experiments on a two-channel X-band active rf pulse compressor that employs gas discharge switch tubes as active elements. The experiments can be understood by reference to Fig. 1, a schematic diagram of the set-up for tests conducted at the X-band magnicon facility at the Naval Research Laboratory. Critical elements in the set-up include the Omega-P/NRL X-band magnicon (2), the quasi-optical 3-dB hybrid directional coupler (3), and the two channels of the compressor itself (1). Each compressor channel consists of a TE<sub>01</sub>-mode energy-storage cavity, and an input/output coupler cavity containing a gas-filled switch tube that can be externally discharged by application of a high-voltage pulse. Both channels function as active Bragg compressors (ABC), with synchronized input-output switchable reflectors. The detailed design of ABC [2] and low-power test measurements on it [3] have been reported previously. In the two-channel compressor scheme (ABC-2), the 3-dB hybrid coupler allows the input drive pulse from the magnicon to be split, with half the power directed to each channel. Upon firing, composite compressed pulses from the two channels are

superimposed in the hybrid, and directed to a high-power load (7). In practice, the load would be replaced by an accelerator section. Two channel ABC-2, in comparison with one channel, allows (i) isolation of the magnicon from power reflected during energy storage, (ii) operation of both channels into one load, (iii) increase in efficiency, and (iv) operation with lower electric field in the gas discharge tube region with a resulting increase in the margin-of-safety against self-breakdown of the plasma switch. Non-vacuum prototypes of ABC-2 tested at low-power levels showed good pulse-to-pulse reproducibility in the shape and amplitude of the compressed pulse, and coherent addition of compressed pulses from the channels [4].

In this brief report, results of preliminary high-power experiments are reported that validate the main goals of the project, which include: (i) simultaneous firing of

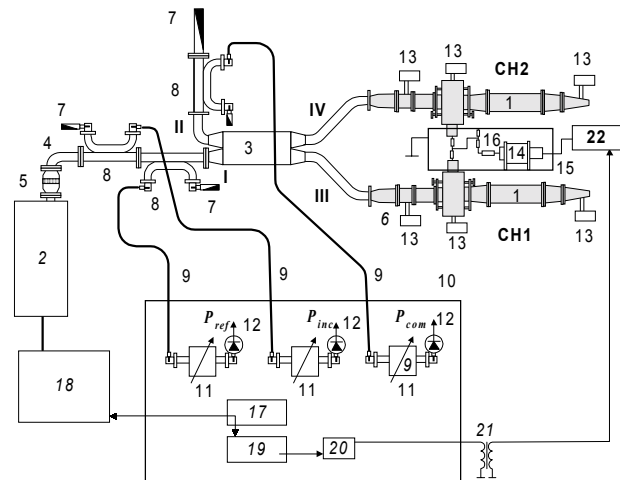

Figure 1. Schematic diagram of the experimental set-up for high-power test of two-channel compressor: 1 – single-channel compressor, 2 - magnicon, 3 – quasi-optical 3-dB directional coupler, 4 – waveguide line, 5 – output window, 6- phase rotator, 7 – matched load, 8 – 55.5-dB directional coupler, 9 – coaxial waveguide, 10 – screen room, 11 – attenuator, 12 – detector, 13 – ion pump, 14 – high-voltage pulse generator, 15 – shielding box, 16 – divider, 17 – trigger generator, 18 – modulator, 19 – delay generator, 20 – trigger amplifier, 21 – pulse transformer, 22 – high-voltage power supply.

\*Sponsored by US Department of Energy.

plasma switch tubes in both channels of the compressor, (ii) operation of the quasi-optical 3-dB hybrid directional coupler, (iii) coherent superposition of rf compressed pulses from the two channels, and (iv) feeding one output arm of the X-band magnicon directly into the rf pulse compressor while the second arm was terminated in a match load. Unfortunately, insufficient time for component bakeout and rf conditioning during the brief first experimental campaign prevented operation at input power levels higher than about 1.5 MW. In the next campaign scheduled to begin in June 2003, tests with higher power input pulses are planned, and more time is to be allotted for bakeout and conditioning.

### EXPERIMENTS

Examples of some results of high-power experiments are shown in Figs. 2-5. Fig. 2 shows the frequency characteristic of the quasi-optical 3-dB hybrid coupler with arms III, and IV terminated in reflecting shorts, and arm II terminated in a matched load. In evidence are balanced splitting of the incident signal at 11.424 GHz from arm I into arms III and IV, and small reflection back into arm I. This is the first high-power operation of this type of quasi-optical 3-dB directional coupler that operates on the principle of image multiplication in oversized rectangular waveguide [4].

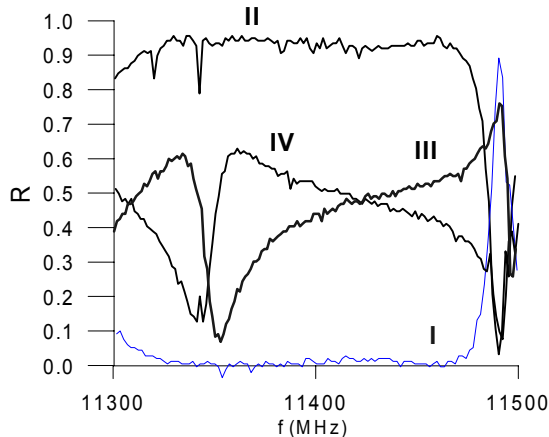

Figure 2. Measured frequency characteristic of the 3dB quasi-optical directional coupler. Note balanced splitting between arms III and IV at 11.4 GHz, as well as low reflection back into arm I.

Fig. 3 shows compressed pulses obtained in each arm individually, when the plasma switch in the opposing arm is not fired. While not identical, the two results show compressed pulses with peak powers of about 2 MW, for an incident pulse of about 1 MW. Fig. 4 shows incident, reflected and output power pulses for the two-channel configuration when the plasma switch tubes are not fired. The difference between incident and output pulses is the energy stored in the ABC-2 compressor. In this example, 61% of the incident rf energy is stored, with the balance being reflected into the output arm of the 3-dB hybrid, mainly during the first half of the pulse. This value of efficiency of energy accumulation is higher than in the

single-channel ABC [3]. Fig. 5 shows three examples of compressed pulses obtained when the plasma switch tubes in both channels are fired simultaneously, using an 80 kV trigger pulse of duration 100 nsec. The maximum power of the compressed pulses reached 11.3 MW within a pulse duration of about 70 nsec.

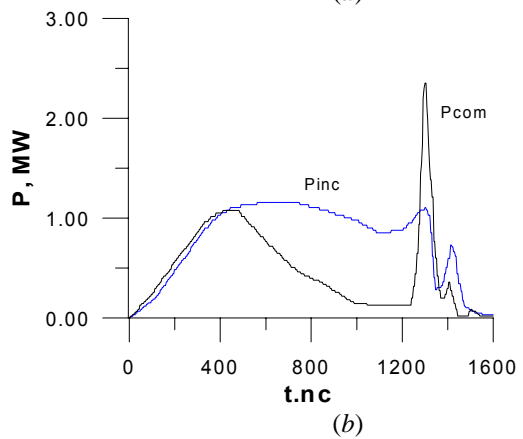
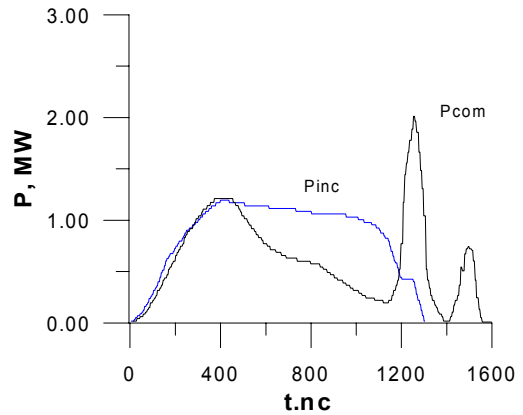

Figure 3. Traces of the compressed pulses obtained separately from each of the compressor channels: (a) channel I; (b) channel II.

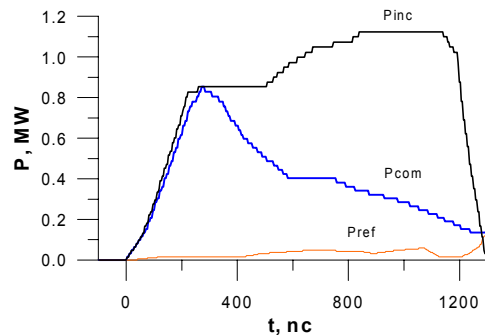

Figure 4. Traces of the incident  $P_{inc}$ , reflected  $P_{ref}$  and output pulses  $P_{com}$  without discharge of plasma switch.

### CONCLUSIONS

1. Coherent superposition of compressed pulses from both channels was demonstrated, as seen by comparing Figs 3 and 5. Compressed pulses with powers of 9–11 MW and

durations of 50–70 nsec were observed, corresponding to power gain ratios  $k$  in the range 8–9.

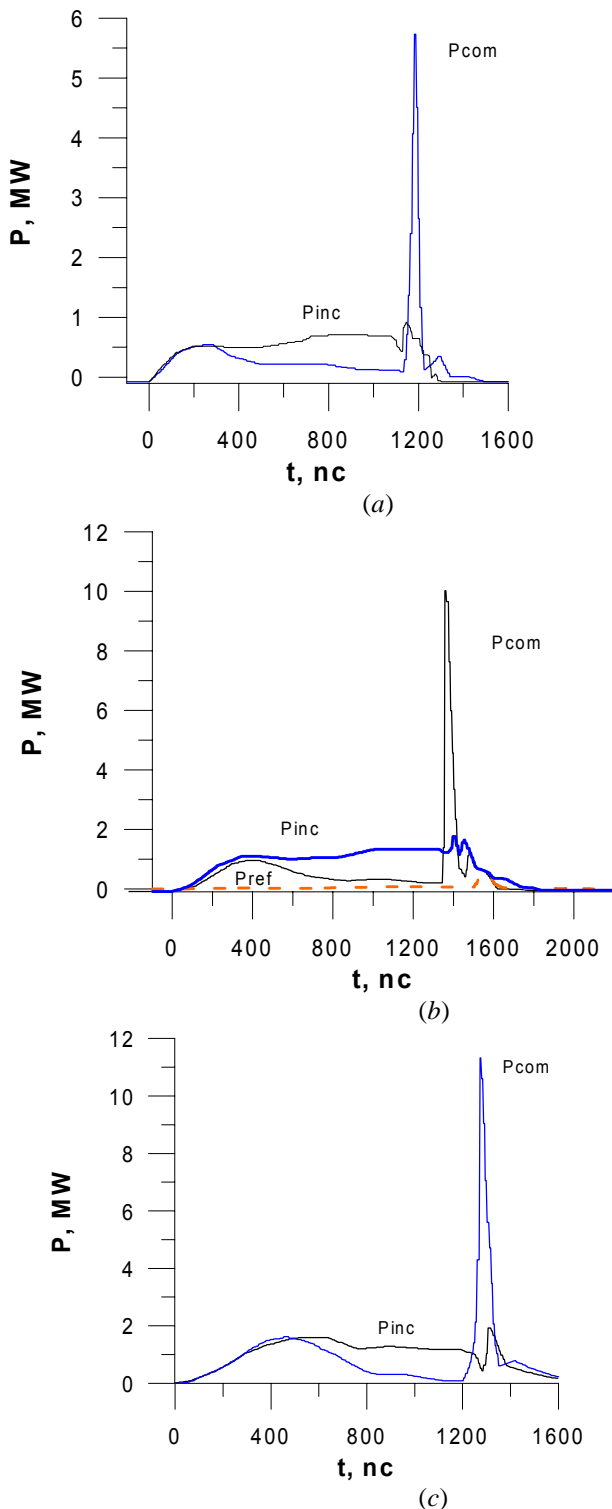

Fig. 5. Oscillogram traces of compressed pulses with external firing of the plasma switches at different values of incident power. The gas pressure in the tubes was  $(2-5) \times 10^{-2}$  Torr.

2. The use of incident power levels  $<1.5$  MW to drive the compressor ABC-2 was required by the appearance at higher powers of microwave breakdowns evidently in the 3-dB directional coupler and the waveguide feed to the compressor. These breakdowns were probably caused by insufficient baking and degassing of the waveguides. Bakeout was not carried out at temperatures  $>100^{\circ}\text{C}$ , nor was prolonged rf conditioning carried out thereafter. Operation with an incident power level of about 12 MW is seen to be required to obtain the 100 MW compressed output pulses that are a goal of this program. At this power level, rf fields in the compressor would be about three times greater than those in the experiments reported here. After full conditioning, each output arm of the magnicon is expected to supply about 25 MW.

3. The need for operation of both channels of the compressor with equal cavity resonant frequencies and equal  $Q$ -factors has been shown to require a means for external monitoring at high power, and for effective external tuning of the cavities. In the experiments reported here, such tuning could only be performed at low power, but detuning due to mechanical movement during pump-down required time-consuming iterations before near equal tunings could be achieved. It is planned to implement a modified tuning procedure during the forthcoming experimental campaign to overcome these difficulties.

**Acknowledgment:** This work was supported by US Department of Energy, Division of High Energy Physics, under SBIR Phase II grant DE-FG02-00-ER 83063 to Omega-P, Inc. and Interagency Agreement DE-AI02-01-ER 41170 with Naval Research Laboratory.

## REFERENCES

- [1] S.G.Tantawi, R.D.Ruth, A.E.Vlieks and M.Zolotarev, "Active high power rf pulse compression using optically switched resonant delay lines," Advanced Accelerator Concepts, 7<sup>th</sup> Workshop, Lake Tahoe, CA, 1996. AIP Conf. Proc., **398**, 813 (1997)
- [2] A.L.Vikharev, A.M.Gorbachev, O.A.Ivanov, V.A.Isaev, S.V.Kuzikov, A.L.Kolyslo, A.L.Litvak, M.I.Petelin, and J.L.Hirshfield, "Active microwave pulse compressors employing oversized resonators and distributed plasma switches," Advanced Accelerator Concepts, 8<sup>th</sup> Workshop, Baltimore, MD, 1998. AIP Conf. Proc., **472**, 975 (1999).
- [3] A.L.Vikharev, A.M.Gorbachev, O.A.Ivanov, V.A.Isaev, S.V.Kuzikov, A.L.Kolyslo, A.L.Litvak, M.I.Petelin, J.L.Hirshfield, O.A.Nezhevenko and S.H.Gold, "100 MW active X-band pulse compressor," Proc. of the 1999 Particle Accelerator Conf., NY, IEEE Conf. Proc., **1-5**, 1474 (1999).
- [4] A.L.Vikharev, A.M.Gorbachev, O.A.Ivanov, V.A.Isaev, V.A.Koldanov, S.V.Kuzikov, A.L.Litvak, M.I.Petelin, J.L.Hirshfield and O.A.Nezhevenko, "Two-channel active high-power X-band pulse compressor," Advanced Accelerator Concepts, 9<sup>th</sup> Workshop- Santa Fe, NM, 2000. AIP Conf. Proc., **569**, 741 (2001).