

PULSED NMR MAGNETOMETERS FOR CESR*

R. E. Meller, D. L. Hartill, LEPP, Cornell University, Ithaca, NY 14853, USA

Abstract

The Cornell Electron Storage Ring (CESR) has recently begun an operating program spanning a wide energy range, from 1.5 to 5.4 GeV. Wide-range magnetometers are necessary for accurate control of the bending fields. These have been implemented using the principle of pulsed nuclear magnetic resonance (NMR). The required field range has been achieved by using a high impedance preamplifier in the field probe to isolate the detection coil, and resonating the coil with high-ratio tuning diodes. A probe installed in a CESR standard bend magnet has been operated continuously from 350 to 2450 gauss using water as the resonance medium, and a second probe in a high field bend magnet has been operated from 860 to 6725 gauss, also using water.

INTRODUCTION

When a nucleus with a magnetic moment is placed in a magnetic field, the nucleus will preferentially align with the magnetic field in the state of lowest energy. If the nuclear magnetic moment is then displaced from alignment, the nucleus will gyrate at the Larmor frequency in the same manner as a torqued gyroscope. The Larmor frequency is determined only by the field strength and the magnetic moment of the nucleus, which is a precisely known constant. The gyrating magnetic moment can be detected with a coupling coil and an RF receiver, and hence, the magnetic field strength can be determined as accurately as RF frequency can be measured. If the magnetic nuclei are contained in an isotropic liquid, such as protons in water, then NMR magnetometry is also independent of probe orientation.

Steady-state NMR

The traditional method of NMR magnetometry [1] involves continuously exciting the nuclei with a steady-state RF signal through a coupling coil with a field axis perpendicular to the main magnetic field. The excitation field will periodically torque the magnetic moments away from alignment, and when the excitation frequency passes through the Larmor frequency, the nuclei will respond resonantly. If the coupling coil has been electrically resonated with an external capacitor, then the nuclear magnetic resonance will cause an absorption dip in the Q of the resonant circuit. This method requires modulation of the excitation frequency or the main magnetic field to reveal the absorption dip. If the magnetic field is not uniform over the excited volume, then the contained nuclei will have a spread

of Larmor frequencies, and the absorption dip will become broad and difficult to resolve.

Pulsed NMR

A more efficient method of NMR magnetometry [2] involves exciting the nuclei to maximum gyration with a short, high-intensity RF pulse, and then detecting the magnetic gyration at the Larmor frequency, the so-called free induction, directly with the coupling coil. In this case, magnetic field nonuniformity will be manifest as the decoherence decay of the free induction. The optimum excitation pulse has a total impulse which rotates the nuclear magnetic moments by 90 degrees from their equilibrium orientation. This method can be further enhanced by the spin-echo technique: Even if the nuclear spins have decohered, an additional excitation pulse of twice the total impulse as the original can be applied. This rotates the nuclear spins by 180 degrees around the axis of the excitation field. This is equivalent to inverting the main magnetic field, which is in turn equivalent to time reversal of the Larmor motion. Hence, the nuclear spins will recombine to form a spin-echo pulse. This pulse is twice as wide as the free induction pulse, and furthermore occurs long after the transmitter transients have died away. These advantages make the pulsed NMR method more reliable and simpler to implement than the steady-state NMR method. The basic time sequence of pulsed NMR is shown in Figure 1.

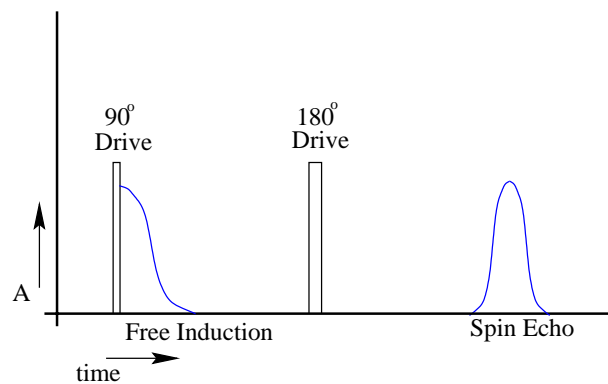

Figure 1: Pulsed NMR signals.

Accurate magnetic field measurement with the pulsed NMR technique requires that the drive pulses be much shorter than the detected pulses. When the width of the drive pulse becomes comparable to the decoherence time, the spectrum of the drive signal begins to overlay the distribution of nuclear frequencies and conceal the natural frequency response. Since the drive pulses are constrained to a given total impulse, their width is inversely proportional

* Work supported by the National Science Foundation

to the transmitter amplitude. Hence, the uniformity of the magnetic field is not an issue as long as sufficient transmitter power is available.

TECHNIQUE

Probe and Preamp

The resonance medium used is protons in water. In pure water, the time for thermal equilibration of the nuclear moments is greater than 2 seconds. This limits the rate at which field measurements can be taken because the measurement completely disrupts the aligned nuclear moments, and a polarized population must be reestablished in order to make another measurement. For this application, 10^{19} /ml cupric ions were added to the water to increase the magnetic coupling of the protons to thermal fluctuations of the liquid. This makes a measurement rate of 10 Hz practical. The doped water is placed in a 1/4" glass tube with the coupling coil wound solenoidally around the tube. Figure 2 represents the schematic of the probe and preamplifier, where L1 is the coupling coil inductance.

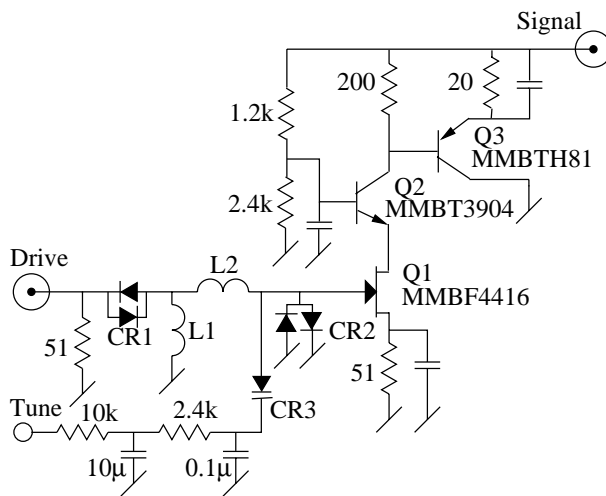

Figure 2: Probe and preamp.

The coupling coil is usually made to be part of a high-Q resonant circuit, since the amplitude signal-to-noise ratio of the detector is proportional to \sqrt{Q} . The largest possible tuning range is achieved if the capacitor is implemented as a high-ratio tuning diode with no additional parasitic capacitance. Hence, the drive switching diodes CR1, CR2, and the cascode-configured JFET Q1 are chosen to minimize parasitic capacitance. The measured tuning ranges are consistent with a total parasitic capacitance of 8 pF. The air-core inductor L2 is included to isolate CR3 and Q1 from the high-amplitude drive pulse. The diode array CR1 switches the drive pulse into the circuit, and CR2 prevents the JFET Q1 and the tuning diode CR3 from becoming forward biased. Therefore, the drive pulse simply drives both L1 and L2 in parallel. When the drive pulse ends, both CR1 and CR2 turn off and thereafter contribute only a small par-

asitic capacitance, and the resonant circuit of L1, L2, and CR3 returns to full Q of approximately 100. Since the detected signal is very small, the tuning diode CR3 bias can be reduced all the way to zero to get the maximum capacitance range. The circuit parameters for the normal field and high field probes are shown in Table 1.

Table 1: Probe parameters

probe	normal field	high field
L1	5.6 μ H	1.7 μ H
L2	2.2 μ H	0.7 μ H
CR3	3 \times MV7404	MV7404
C_{min}	35 pF	18 pF
f_{max}	9.6 MHz	24.2 MHz
C_{max}	840 pF	280 pF
f_{min}	1.96 MHz	6.10 MHz

The gain of the preamplifier depends on the transconductance g_m of Q1 and the current gain β of Q3, but at low frequencies it is typically > 10 . The signal level increases with frequency, since the greater magnetic field increases the polarization of the water sample. Since the preamplifier is located in the magnetic field with the coupling coil, it must be made with substantially nonmagnetic components to avoid corrupting the uniformity of the magnetic field being measured. This poses a significant problem, since steel leads are prevalent in electronic components, particularly on capacitors and diodes. The preamplifier was made entirely with surface mount components. The transistors and diodes in SOT packages are essentially nonmagnetic. The resistors and capacitors have nickel end caps, but the small size minimizes the quantity of magnetic material and allows them to be positioned well away from the resonance capsule.

Receiver

The spin-echo signal is detected by mixing it with a reference frequency derived from an accurate frequency synthesizer. Two channels with a 90 degree phase difference between the references are used to produce sine-like and cosine-like IF (Intermediate Frequency) signals. This allows a signed beat frequency to be reconstructed from a single measurement, and eliminates the need to sweep the reference frequency to determine which side of resonance it is on. The receiver consists of resistor-capacitor filters and common analog integrated circuits. The gain 100 unit is a 733 differential amplifier, and the gain 20 units are implemented with op-amps. Since the reference signals are derived from a programmable logic circuit, it is simple to gate them off while the transmitter is active to reduce the overload recovery time of the op-amps. The receiver block diagram is shown in Figure 3. The +8VDC bias voltage for the probe preamplifier is coupled to the signal input through a ferrite choke.

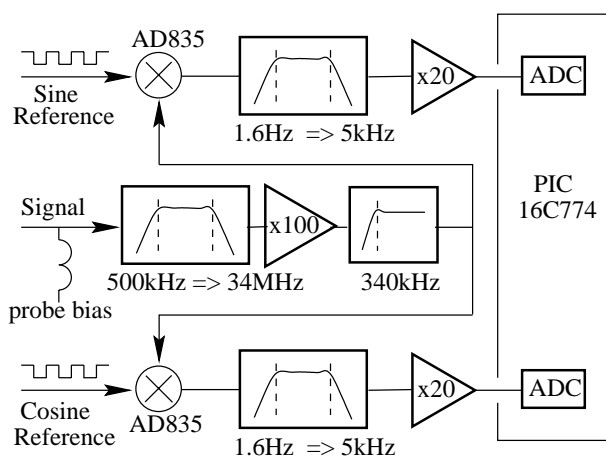

Figure 3: Receiver block diagram.

Transmitter

The transmitter is shown in Figure 4. The 10 volt avalanche diodes are necessary to clamp ringing when the power switching transistors turn off. The output is 20V p-p with a large signal impedance of 2Ω . Hence, the transmitter is capable of significantly higher output power with a suitable transformer ratio. It is very important to prevent the reference carrier frequency from leaking into the drive when the transmitter is off, as it will capacitively couple through the switching diodes in the probe and overload the receiver. To this end, the transmitter should have a power supply that is completely isolated from other RF circuits.

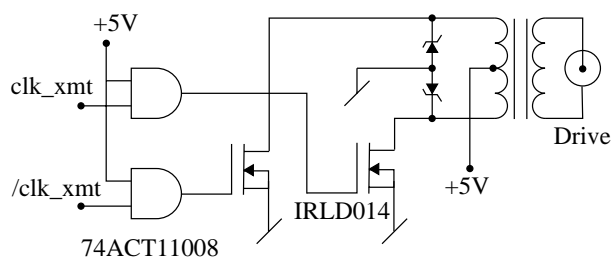

Figure 4: Transmitter.

Frequency Synthesizer

The absolute accuracy of an NMR magnetometer is determined by the accuracy of the frequency synthesizer reference clock. A 20 MHz temperature-compensated crystal oscillator which is specified to 8×10^{-6} absolute accuracy over ten years has been used. This accuracy level is relatively inexpensive, and corresponds to approximately one centigauss in the CESR standard bend magnet. This oscillator is used to clock a direct-digital synthesizer which produces sinusoids up to 1.8 MHz. The sinusoidal reference is then converted to a logic level and multiplied by 64 using a phase-locked loop frequency multiplier circuit similar to the one used for CESR timing [3]. The resulting frequency is divided down in a programmable logic device

to produce the sine and cosine reference signals and the transmitter clock in the appropriate range, up to 28.8 MHz with 40 Hz resolution. This maximum frequency allows field measurements up to 6760 gauss.

Data Processing

All data processing is done with a PIC16C774 8-bit microcontroller. This unit includes a 12-bit analog to digital converter (ADC), and with the maximum clock rate of 20 MHz it can digitize both IF signals at 15 kHz. Each IF signal is sampled 16 times over 1 ms at the peak of the spin-echo. For each sample, the tangent of the phase angle is obtained as the quotient of the two IF amplitudes, and the phase angle itself is obtained from a lookup table. Then a linear least-squares fit is done to the 16 phase measurements, with the beat frequency appearing as the slope of the fit. Frequency tracking is accomplished by shifting the digital synthesizer command by the beat frequency to obtain a zero-beat condition. The digital frequency command is then reported as the magnetic field measurement.

The sampling rate of 15 kHz limits the tracking range to ± 1.5 gauss. Initial capture and recapture are accomplished by sweeping the synthesizer over a range of ± 30 gauss from the last known signal, with 0.5 gauss steps between measurements. This results in reliable resonance capture within 13 seconds.

RESULTS

The instruments described were developed over several months using common and inexpensive components. They require programming with tuning, pulse width, and search frequency data for the magnetic field to be measured. However, having made tables of suitable programming values, the instruments have been completely reliable and attention-free over the entire working field range of the CESR bending magnets.

When the probe is tuned to resonance, the IF signals are 30 dB above thermal and semiconductor noise. The good signal to noise ratio of the spin-echo method has allowed the extension of the measurement range well beyond the probe tuning range, which has facilitated continuous magnetic history measurements of the magnet iron. The 10 Hz measurement rate has revealed both random and periodic noise in the magnet power supplies that was not visible to the steady-state NMR magnetometers which were previously employed.

REFERENCES

- [1] N.Bloembergen, E.M.Purcell, and R.V.Pound, *Phys. Rev.* vol. 73, 679 (1948)
- [2] E.L.Hahn, *Phys. Rev.* vol. 80, 580 (1950)
- [3] R.E.Meller, *Proceedings of the 1997 Particle Accelerator Conference, Vancouver, Canada* (IEEE, Piscataway, NJ, 1999) p.2505