

THE UPGRADE OF HLS LINAC CONTROL SYSTEM

G. Liu*, W. Li, C. Li, J. Li†, L. Chen, X. Bao, J. Wang

National Synchrotron Radiation Lab., P. O. Box 6022, Hefei, Anhui 230029, P. R. China

Abstract

The linac control system of Hefei Light Source (HLS) was initially build in late 1980's, and a concerted effort has been put forth to upgrade it to a new, distributed one based on EPICS. Industrial PC based hardware is widely used as not only IOC but also front-end controller. Besides industrial PC, PLC and single-chip microcomputer are also used as front-end controllers in some subsystems. The software for industrial PC based front-end controller is developed based on vxWorks real-time operating system. The software for PLC and single-chip microcomputer are written with ladder software package and assemble language respectively. PC with Linux operating system and SUN workstation with Solaris operating system are used as operator interfaces. High level control is made up of some EPICS tools and Tcl/Tk scripts.

INTRODUCTION

HLS is a second-generation dedicated synchrotron light source. It consists of a 200 MeV linac, a beam transport line, and an 800 MeV electron storage ring [1]. The linac control system was initially build in late 1980's [2]. Except some subsystems, most of the system were not computerized. In the computerized subsystems, personal computer (PC) and single board computer were used as operator interface and front-end controller respectively. RS232 and RS422 were used for the communication between PC and single board computers. It used a different communication protocol from the storage ring control system which had been upgraded using Experimental Physics and Industrial Control System (EPICS) [3]. For ease of communication with the storage ring control system and operation, a concerted effort has been put forth to upgrade the linac control system to a new, distributed one based on EPICS in the last two years.

In HLS linac, there are a large number of magnet supplies, beam measurement equipment, and devices in vacuum system, accelerating system, and interlock system. All of the devices and equipment need to be controlled and monitored by the control system. The upgrade has performed in several stages. By now, the following subsystems have accomplished:

- Linac magnet power supply control and monitoring;
- Linac vacuum monitoring;
- Linac flag control and monitoring;
- Interlock system;
- Klystron focus power supply control and monitoring;

- Modulator pulse power supply control and monitoring.

HARDWARE

Hardware structure

The "standard model"[4] is used for HLS Linac control system, which consists of operator interface, input/output controller(IOC) and front-end controller. Fig. 1 gives an overview of the hardware structure of HLS linac control system. A SUN workstation and some PCs are used as operator interfaces to perform high level control. Industrial PC based hardware is widely used in HLS linac control

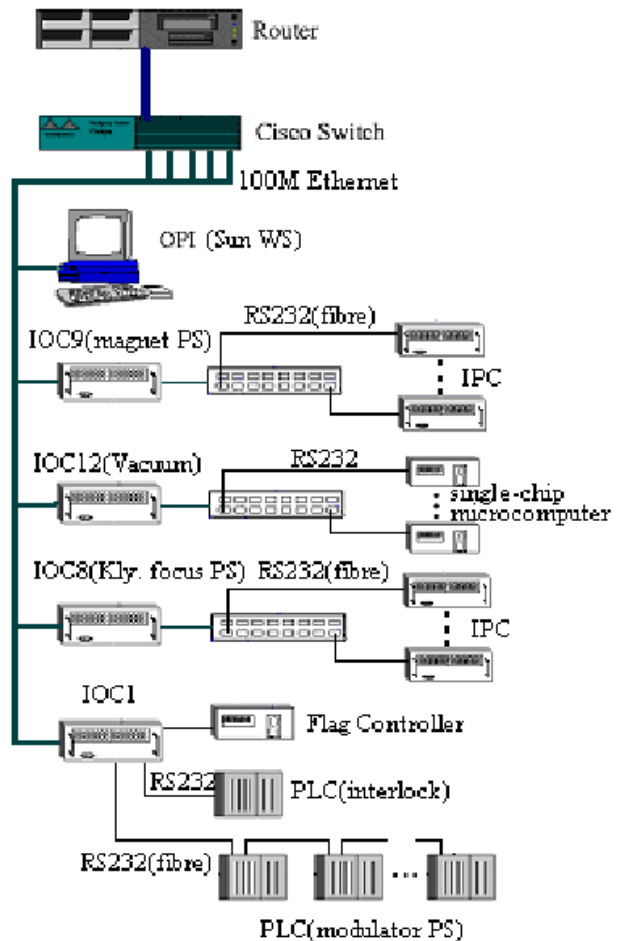

Figure 1: Overview of HLS linac control system.

system. It is used as not only front-end controller but also IOC. Besides PC based hardware, programmable logic controller (PLC) and single-chip microcomputer are also

* gfliu@ustc.edu.cn

† Currently works at FEL Lab, Duke University

used as front-end controllers. For example, single-chip microcomputers are used to control and monitor linac vacuum subsystem, and PLCs are used in the interlock system and modulator pulse power supply system. The RS232 serial protocol is used for the communication between IOC and front-end controller. The MOXA's multi-serial card, C168P, is used to add up more serial ports for IOCs. 100M-Ethernet is used for the local area network (LAN) to get high network transport speed. Shielded cable and optical fiber are used for the communication media.

Industrial PC based front-end controller

The industrial PC based front-end controller is mainly used to control and monitor the magnet and klystron focusing coil power supplies. Fig. 2 illustrates its hardware structure which is based on ISA bus technology. Because the specifications of the power supply that are controlled by this type of controller are about 1000 ppm, the 12-bit DAC and ADC cards are used to set and read the power supply current. Relay and digital-in cards are used to control and monitor the power supplies' status respectively. The chan-

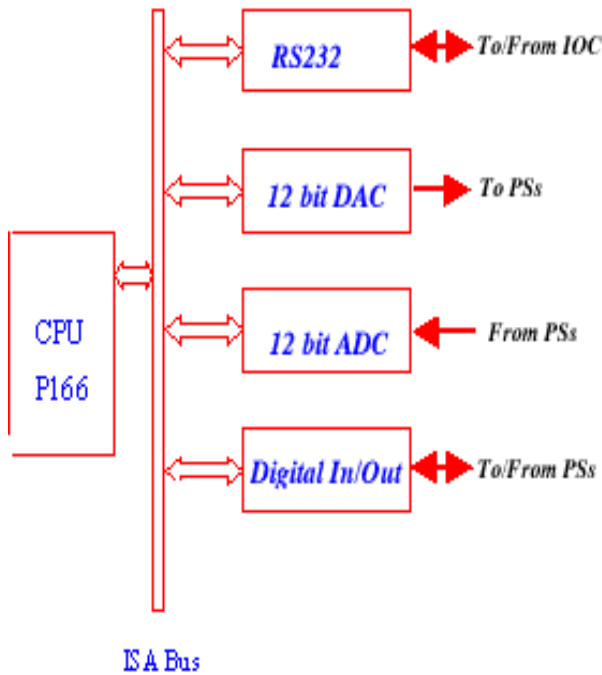

Figure 2: Hardware structure of industrial PC based front-end controller.

nels of these control and monitor cards are determined by the number of power supplies that the controller controlled. To avoid the electro-magnetic interference (EMI) between the controller and the power supplies, optical isolation is adapted in these controllers.

SOFTWARE OVERVIEW

Software of front-end controller

The software for industrial PC based front-end controller has been developed based on VxWorks multi-task mechanism, which consists of three parts (see Fig. 3): communication module, main loop module, and device drivers. The communication module is used to receive/send messages from/to IOC. The main loop module is used to parse the command and data from the message received by communication module and call the corresponding device driver according to the command. It will send messages to the IOC if it gets a read command. The device drivers are used to access the hardware or software channels.

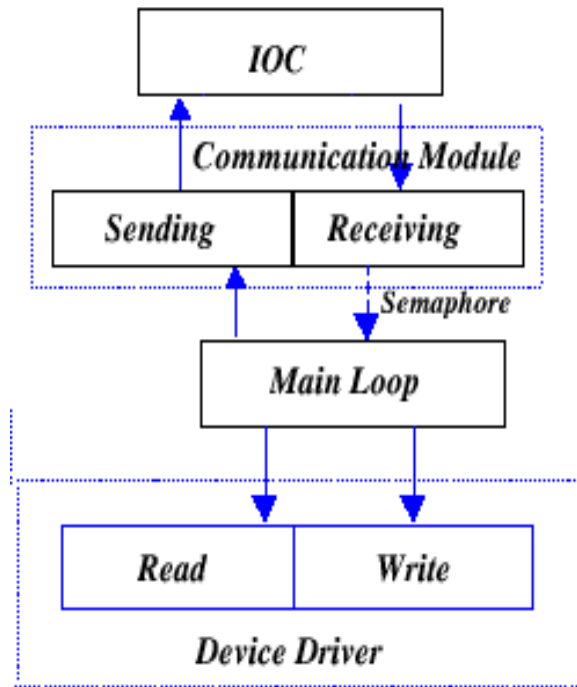

Figure 3: Software structure of industrial PC front-end controller.

The software for PLC is written with ladder software package (LSS), and assemble language is used to develop the software for single-chip microcomputer.

Software of IOC

There are about 1,000 records resident in four IOCs, which made up of the distributed database of the linac control system. The following record types are used: AI, AO, BI, BO, Mbbi (Multi-bit Binary Input), Mbbo (Multi-bit Binary Output), MbbiDirect (Direct Multi-bit Binary Input), MbboDirect (Direct Multi-bit Binary Output), and subroutine. The device support and device drivers for these record type have been developed to access input/output

hardware or field-bus adapter [5]. The state notation language and sequencer are used to perform a number of commands, for example, to interlock and protect the devices.

Some EPICS tools are used for high level control. For example, MEDM is used to edit and manage the control interface screens, Alarm handler (ALH) is used to monitor the alarm status of some devices, for example power supply alarm . status

A number of Tcl/Tk [6] scripts have also been developed to perform high level control, which are used in the routine machine operation and machine study. For example, they are used for the power supply setpoint backup and restore, turning power supplies on and off, magnet cycle, and so on.

CONCLUSION

Most of the subsystems of HLS linac control system have been in operation for a period of time, and the performance is as good as expected. Our experiences have proven that a control system that is build with inexpensive but reliable controllers, for example industrial PC, PLC, and single-chip microcomputer, not only is extremely cost effective but works fine.

REFERENCES

- [1] W. Li, et al, "Upgrade plan for the NSRL control system", ICALEPCS'97, Beijing, China, 1997.
- [2] Rongsheng Xie, "The control system of the Hefei 200 MeV electron linac", Proceedings of the international conference on synchrotron radiation application, Hefei, Chian, 1989.
- [3] Martin Kraimer, "EPICS Input / Output Controller (IOC) Application Developer's Guide", EPICS Documentation on <http://www.aps.anl.gov/asd/controls/epics/EpicsDocumentation>.
- [4] W B. Kuiper, "Issues in Accelerator Proceedings Conference on of International Accelerator and Large Experimental Physics Control Systems", (ICALEPCS 91), Tsukuba, Japan, November 1991, pp. 602-611.
- [5] Philip Stanley, Janet Anderson, Martin Kraimer, "EPICS Record Reference Manual", EPICS Documentation on <http://www.aps.anl.gov/asd/controls/epics/EpicsDocumentation>.
- [6] Brent Welch, "Practical Programming in Tcl and Tk", published by Prentice Hall: ISBN 0-13-182007-9.