

PROGRESS ON HIGH POWER TESTS OF DIELECTRIC-LOADED ACCELERATING STRUCTURES*

C. Jing[#], J. G. Power, R. Konecny, and W. Gai, ANL, Argonne, IL 60439, U.S.A.
 S. H. Gold, Plasma Physics Division, NRL, Washington DC 20375, U.S.A.
 A. K. Kinkead, LET Corp., Washington DC 20007, U.S.A.

Abstract

To evaluate the Dielectric-Loaded Accelerating (DLA) structure as a potential alternative high-gradient accelerator, a series of high power RF experiments have been carried-out by a joint Argonne National Laboratory/Naval Research Laboratory program. We have tested DLA structures loaded with two different ceramic materials, alumina and $Mg_xCa_{1-x}TiO_3$. For the alumina tube, we concentrated on the study of the multipactor effect in the DLA structures under the high power rf field. In the $Mg_xCa_{1-x}TiO_3$ tests, we mainly investigate the local field enhancement that caused dielectric joint breakdown of the DLA structures. In both cases, physical models have been set up, and the corresponding engineering solutions are being implemented.

INTRODUCTION

High-gradient accelerators based on the dielectric-lined waveguide have been an important subject of study in recent years [1-3]. Over the last several years, an Argonne National Laboratory (ANL) – Naval Research Laboratory (NRL) joint research program has carried out a series of high-power RF tests on X-Band traveling-wave dielectric-loaded accelerating (DLA) structures and several new physics phenomena have been discovered and investigated. The structures are developed at ANL and the high-power tests are carried out at NRL.

Previous tests results for two DLA structures loaded with different ceramics, alumina and $Mg_xCa_{1-x}TiO_3$ (MCT) have been reported in [4] and [5] respectively. In this paper, we will present the most recent experimental data, which includes the multipactor suppression studies for the alumina-based DLA structure, and the experiment on reducing the local field enhancement for the MCT-based DLA structure.

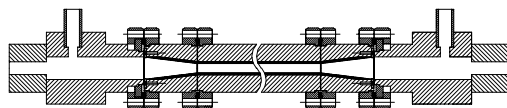

Figure 1: Schematic drawing of modular dielectric loaded accelerating structure.

The structure we tested is a modular (DLA) structure which consists of three functional parts (see Fig. 1): (1) RF couplers that convert between the TE_{10} mode in the rectangular waveguide and the TM_{01} mode in the circular copper waveguide at the input and output ends; (2) the

tapered dielectric matching sections used to match the impedance of the TM wave in the coupler to the acceleration section; (3) the uniform dielectric-loaded accelerating section used for acceleration.

The geometric and physical properties of both the alumina and MCT-based DLA structures are shown in Table 1.

Table 1: Parameters of 11.424 GHz DLA Structures

parameters	Value	
Material	Alumina	$Mg_xCa_{1-x}TiO_3$
Dielectric constant	9.4	20
Inner radius	5mm	3mm
Outer radius	7.185mm	4.57mm
Shunt impedance	30.3MΩ/m	25.1 MΩ/m
R/Q	6.9kΩ/m	8.8 kΩ/m
Group velocity	0.134c	0.057c
RF power needed to support 1MV/m gradient	80kW	27kW

As in the prior experiments, we used the X-band Magnicon facility at NRL [6] as the external high-power RF source to test the DLA structures. The Magnicon provides up to ~12 MW of 11.424 GHz power with a 200 ns pulse length from either of its two output arms. Figure 2 shows the experimental layout and diagnostics used: directional couplers are used to monitor the reflected, incident and transmitted signals; four ion pumps are used to evacuate and to monitor the vacuum level in the system; and two CCD cameras are used to look for visible light along the axis of the structure (in the event of arcing) from both the upstream and downstream ends. The vacuum pressure of the system was kept under 10^{-7} Torr during the high power test.

MULTIPACTOR SUPPRESSION

To suppress multipactor in the alumina-based DLA structure, we coated the inner surface of the alumina tube with a 20-nm-thick TiN film. In Figure 3, the results of the high-power RF tests of both the TiN-coated structure and an identical, but non-coated structure [4] are plotted together for comparison. Due to the slightly different values of the transmission coefficient at low incident power (caused by assembly variation) we normalized the transmission percentage for easy comparison between structures. There are two main differences between the two transmitted power curves. (1) The percentage of

*Work supported by the US Department of Energy, Office of High Energy Physics and the Office of Naval Research.
[#]jingchg@hep.anl.gov

transmitted RF power begins to decrease (caused by the onset of multipactor) at an incident power of 200 kW (equivalent to an accelerating gradient of 1.6 MV/m at the upstream end) in the TiN-coated structure and at 80 kW (1 MV/m) in the non-coated structure. (2) The percentage of transmitted power saturates at an incident power of 1 MW (3.7 MV/m) in the TiN-coated structure, but does not saturate in the non-coated structure.

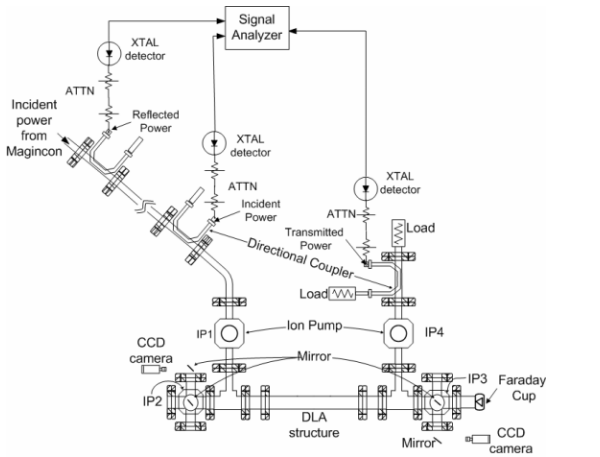

Figure 2: Experimental setup used to test DLA structures with high power RF.

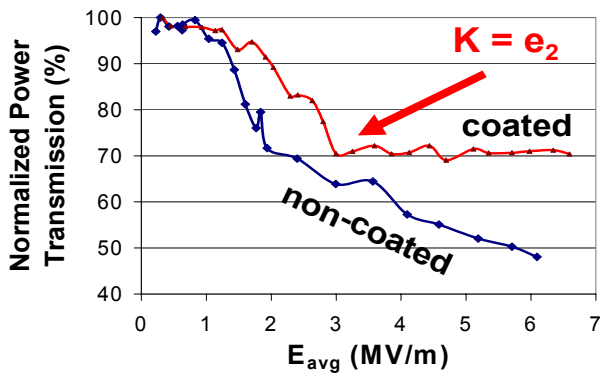

Figure 3: Comparison of the transmitted power for the coated and non-coated alumina-based DLA structures. Saturation occurs when the impact energy (K) is greater than the second crossover energy (e_2).

The cause of the saturation of the RF power transmission curve in the TiN-coated structure is under investigation. Our preliminary conjecture is that the saturation occurs when the impact energy (K) of the most energetic secondaries exceeds the second cross-over energy (e_2). In this case, the secondaries do not multiply since the secondary electron emission (SEE) coefficient (δ) is less than 1 when $K > e_2$. While e_2 for alumina is approximately 10 keV [4], the TiN coating lowers e_2 significantly. Simulations reveal that $K=1.5$ keV at $E=3.0$ MV/m much smaller than that of non-coated alumina-based DLA structure so that RF power absorption curve saturated earlier.

To further investigate the multipactor process, we introduced a uniform axial magnetic field using a solenoid installed outside the coated alumina-based DLA structure. Figure 4 shows the effect of the solenoid. For both the region below multipactor onset (incident power below 200 kW) and the saturation region (incident power above 1 MW) the applied 150 Gauss axial magnetic field had no effect on the RF power transmitted. However, in the central region, this axial field caused a slight increase in the RF power absorption,

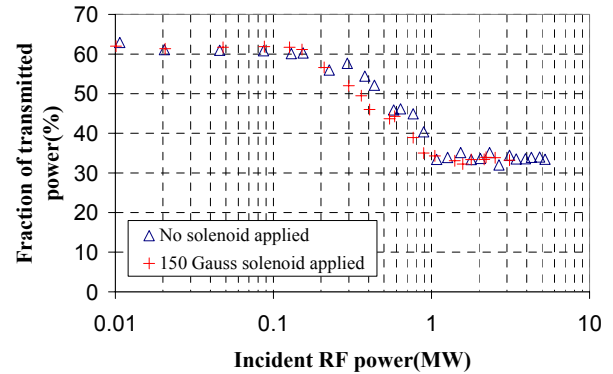

Figure 4: Transmitted RF power as a function of incident power with and without an axial magnetic field applied. In the central region, from 200 kW to 1 MW, the magnetic field increased the power absorption. Otherwise, the applied magnetic field did not show any measurable effect.

REDUCTION OF THE LOCAL FIELD ENHANCEMENT

So far, we have carried out three high power experiments on $Mg_xCa_{1-x}TiO_3$ (MCT) based DLA structures [5] and all of them showed a similar arcing phenomenon. Based on these tests, the breakdown is believed to be caused by the existence of a micro scale vacuum gap in the dielectric butt joint; although the exact physical mechanism of the breakdown has not been totally understood yet. Due to the large dielectric constant discontinuity at the joint, there is a strong enhancement of the local electric field. Based on the continuity of electric flux density, the local longitudinal electric field should be enhanced by 20 (ϵ) times compared to the ideal (joint free) case. For this MCT DLA structure, the accelerating field is around 5.7 MV/m at the upstream end-taper when 1 MW of incident power is applied. We can then estimate that the electric enhancement at the gap to be 100 MV/m [5]. One solution we attempted was to fill the joint with a filler (ϵ_f) so the field enhancement ratio would be reduced from $\epsilon_{mct}/\epsilon_{vac} = 20$ to $\epsilon_{mct}/\epsilon_f$ in the joint. This should allow the structure to reach a higher accelerating gradient before reaching the dielectric breakdown threshold in the joint.

The first filler tested was an epoxy resin with a dielectric strength of 2.4 kV/mil and a dielectric constant of 5.2. This means that the local field enhancement ratio

is reduced from 20 to $20/5.2 = 3.8$. The demonstration experiment was carried out in January 2005. A thin film of epoxy was put on the end surface of the two taper joints of the MCT-based DLA structure. But in the process, the thickness and the flatness of the filling are hard to control due to its viscosity. The tube was baked 30 minutes @177 °C to cure.

Cold tests showed that the RF transmission and reflection of this structure were degraded compared to the non-epoxy structure. For example, S21 dropped to -3.8 dB and S11 of -5.5 dB at 11.43GHz (S21 of -2.5 dB and S11 of -9 dB for the previous non-epoxy tube). This is because the epoxy formed bumps along the inside of the tube causing electrical discontinuities and it was lossy.

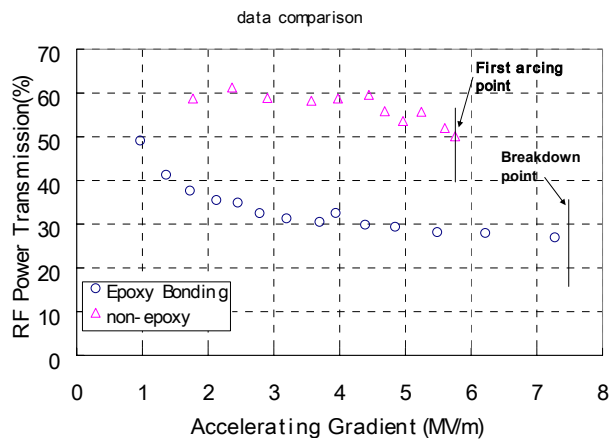

Figure 5: Comparison of the high power RF transmission of two experiments: the non-epoxy MCT DLA structure and the epoxy bonded one.

Figure 5 shows the high power RF performance of the epoxy bonded MCT DLA structure compared to the non-epoxy case. During the high power RF testing on the epoxy tube, the fraction of the transmitted RF power dropped very fast at the beginning (from 50% to 30%), and then the dropping speed becomes very slow. The reflection performance (not shown) corresponds to the transmission roughly. The reflection started to increase fast and then slowed down while raising the incident RF power. From the curve, we notice that the experimental behaviors of two MCT DLA structures (with and without epoxy filling) are totally different. The reason is that the characteristics of the epoxy under the high vacuum and high field condition dominated the overall RF responses of the DLA structure in the experiment.

The dielectric tube had suddenly broken down (with strong transmitted RF signal shutdown and total RF reflection simultaneously) at the incident power of 1.9MW where the accelerating gradient had reached 7.3 MV/m, and the local electric field at the upstream ceramic joint should be around 30MV/m by the enhancement ratio of 3.8. Compared to the non-epoxy MCT DLA structure experiment shown in Figure 5, the epoxy filling does have a certain level of improvement but only limited by the

epoxy breakdown voltage instead of the loaded dielectric, $Mg_xCa_{1-x}TiO_3$.

FUTURE WORK

Dielectric-loaded accelerating structures may provide an alternative high-gradient accelerator. However, we must find a more effective method to suppress the multipactor and eliminate the local field enhancement in the dielectric joints. A new gap-free DLA structure is under design which is expected to overcome the breakdown occurred in the ceramic joints. And new multipactor suppression techniques are under investigation.

REFERENCES

- [1] Peng Zou, W. Gai, R. Konecny, X. Sun, T. Wong, and A. Kanareykin, "Construction and Testing of an 11.4 GHz Dielectric Structure Based Traveling Wave Accelerator," *Rev. Sci. Instrum.*, Vol.71, No.6, pp. 2301-2304, 2000.
- [2] T. B. Zhang, J. L. Hirshfield, T. C. Marshall, and B. Hafizi, "Stimulated dielectric wake-field accelerator," *Phys. Rev. E*, vol.56, pp. 4647-4655, 1997.
- [3] Wei Gai, P. Schoessow, B. Cole, R. Konecny, J. Norem, J. Rosenzweig, and J. Simpson, "Experimental Demonstration of Wakefield Effects in Dielectric Structures," *Phys. Rev. Lett.*, Vol. 61, pp. 2756-2758, 1988.
- [4] J. G. Power, W. Gai, S. Gold, A. Kinhead, R. Konecny, C. Jing, W. Liu, and Z. Yusof, "Observation of Multipactor in an alumina-Based Dielectric-Loaded Accelerating Structure", *Phys. Rev. Lett.*, Vol.92, No.16, 164801, 2004.
- [5] C. Jing, R. Konecny, W. Gai, S. Gold, J. Power, A. Kinhead, and W. Liu, "High Power rf Test on X-band $Mg_xCa_{1-x}TiO_3$ Based Dielectric-Loaded Accelerating Structure," *Proc. AAC 11th Workshop, AIP Conf. Proc. 737*, New York, pp. 258-264, 2004.
- [6] Steven H. Gold et al, "High Power Accelerator R&D at the NRL 11424-GHz Magnicon Facility," *Proc. AAC 10th Workshop, AIP Conf. Proc. 647* pp. 439-447, 2002.