

## FIRST RESULTS ON THE PATH TOWARDS A MICROWAVE-ASSISTED H<sup>-</sup> ION SOURCE\*

R. Keller, P. Luft, M. Regis, J. Wallig, M. Monroy, A. Ratti, and D. Syversrud  
LBNL, Berkeley, CA 94720, USA

R. Welton and D. Anderson, ORNL, Oak Ridge, TN, 37830-6473, USA

### Abstract

A novel concept for creating intense beams of negative hydrogen ion beams is presented. In this approach, an ECR ion source operating at 2.45 GHz frequency is utilized as a primary plasma generator and coupled to an SNS-type multi-cusp H<sup>-</sup> ion source. The secondary source is driven by chopped dc power, thereby avoiding the use of filaments or of an internal rf antenna. The development of the new ion source is aimed at supporting the future beam-power goal of 3 MW for the Spallation Neutron Source (SNS) accelerator systems that will be pursued after the start of SNS operations, but application to other proton driver accelerators that include an accumulator ring is feasible as well. The first three phases of this development effort have been successfully completed: assembly of a test stand and verification of the performance of an rf-driven SNS ion-source prototype; extraction of electrons up to 1.5 A current from a 2.45-GHz ECR ion source obtained on loan from Argonne National Laboratory; and creation of a plasma in the H<sup>-</sup> discharge chamber with a pulsed discharge current of 12 A. The next goal is the demonstration of actual H<sup>-</sup> ion production by this novel, hybrid ion source. This paper describes the source principle and design in detail and reports on the current status of the development work.

### INTRODUCTION

The H<sup>-</sup> ion source built by LBNL for the Spallation Neutron Source (SNS) project in Oak Ridge has demonstrated excellent peak performance during the commissioning [2] and re-commissioning [3] of the SNS Front End (linac injector), exceeding the project requirements. A significant performance improvement overall will be required, however, with a planned future upgrade to an average beam-power of 3 MW. In view of future needs of SNS as well as other ring-based proton drivers, the following performance parameters have been selected as R&D goals:

- 75 mA peak H<sup>-</sup> current
- 0.25  $\pi$  mm mrad normalized rms emittance
- 12% duty factor
- 2 months time-between-services

In spite of significant improvements in the design of the rf antenna implemented during the Front End construction phase, it appears that the approach utilizing an internal antenna and 2-MHz rf power to create the source plasma is not promising enough to pursue further. Instead,

a novel approach is described in this paper, with the main source plasma being created by a pulsed d. c. discharge but sustained by a plasma cathode, rather than thermionic filaments which are the cause for the rather short lifetime of conventional H<sup>-</sup> sources.

Inspired by the demonstrated durability of Electron Cyclotron-Resonance (ECR) proton sources developed at CRNL Chalk River [4], LANL Los Alamos [5], and CEA Saclay [6], an ECR plasma generator operating at 2.45 GHz frequency was chosen as plasma cathode, now with electrons extracted instead of ions and injected at moderate energy into an SNS-type multi-cusp H<sup>-</sup> ion source.

The first three phases of this development have been successfully passed: assembly of a test stand and verification of the performance of an rf-driven SNS ion-source prototype; extraction of electrons with up to 1.5 A current from the 2.45-GHz ECR ion source obtained on loan from Argonne Nat. Lab [7]; and creation of a plasma in the H<sup>-</sup> discharge chamber with a pulsed discharge current of up to 12 A. The next goal is the demonstration of actual H<sup>-</sup> ion production by this novel, hybrid ion source.

Two- or multi-stage ion sources have been described more than 40 years ago [8, 9], and coupling of an rf driven plasma generator with a conventional dc ion source had been suggested in a review paper [10]. The electrode-less discharge technique associated with Electron Cyclotron Resonance (ECR) ion sources is in principle convenient for H<sup>-</sup> ion sources as well, but so far only modest plasma densities have been achieved, allowing extraction of beam currents below 5 mA [11] or less [12, 13] as compared to 61 mA needed for 3-MW operation of the SNS. On the other hand, tests of a two-chamber source for positive ions with a microwave-driven plasma cathode were very successful and achieved 110 mA Ar<sup>+</sup> as well as 43 mA of oxygen ions where the discharge could be maintained for 50 hrs [14].

One explanation for the rather weak H<sup>-</sup> beam currents so far obtained from conventional ECR discharges could be seen in the presence of copious amounts of energetic primary electrons penetrating into the H<sup>-</sup> production region in spite of an installed magnetic filter; these electrons would rapidly destroy the generated H<sup>-</sup> ions [15]. The hybrid discharge concept chosen for HYBRIS (HYBRid Ion Source) has a chance to circumvent this loss process because energetic primary electrons should be thermalized in the main discharge before they reach the magnetic filter that separates the H<sup>-</sup> production chamber from the main discharge.

\*Work supported by Office of Basic Energy Sciences, U.S. Department of Energy under Contract DE-AC03-76SF00098.

## LAYOUT AND PRINCIPLE OF OPERATION FOR HYBRIS

The principal idea in the layout of HYBRIS, see Fig. 1, is the combination of a long-life plasma cathode, sustained by an electrode-less ECR discharge, with a stationary, pulsed discharge. The 2.45-GHz ECR ion source as described in Ref. [4], obtained on loan from Argonne National Laboratory [7] complete with ancillary systems, utilizes up to 2 kW of cw microwave power, and the axial magnetic field in the order of 900 G is generated by two solenoid coils.

With the original version of HYBRIS, electrons were extracted from the ECR and injected into the H<sup>-</sup> discharge chamber to ignite and sustain its plasma. At first an accel/decel approach involving a dedicated extractor tube was followed, and later the two plasma generators were coupled as shown in Fig. 1 and a bias voltage applied between them. In the latest experiments, the bias was eliminated, quasi-neutral plasma flows through an aperture in the ECR outlet electrode into the H<sup>-</sup> discharge chamber, and a high-voltage spark assists the ignition of a pulsed dc discharge there.

The main chamber consists of the multicusp vessel of the ‘startup’ SNS H<sup>-</sup> source which is identical to the production version [2] except for a few minor technical details. But its former rf antenna assembly is replaced by the cathode flange into which the primary plasma flows, and the pulsed discharge is struck between this cathode and the multicusp chamber acting as the anode. The discharge pulser unit includes a 12.5-Ω resistor connected in series.

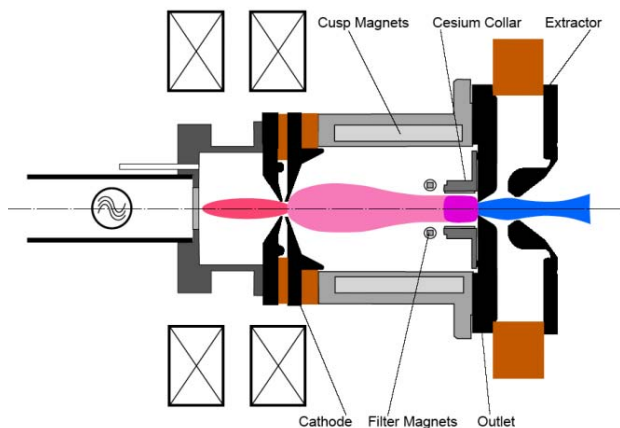

Figure 1: Schematic diagram of HYBRIS. ECR chamber with waveguide and solenoid coils, left; H<sup>-</sup> discharge chamber, center; extraction system, right.

For use in the SNS accelerator chain, the ion source would be pulsed at a duty factor of 6%. The gas supply is connected to the ECR chamber, and the gas flow is adjusted according to the needs of the main discharge. While the ECR discharge can be maintained at a flow as low as 2.5 sccm, ignition of the main discharge requires a minimum of about 10 sccm.

As with the SNS ion source, a magnetic filter separates the H<sup>-</sup> production volume inside the cesium collar from the main discharge to prevent energetic electrons from entering; ions and low-energy electrons can penetrate this barrier much more easily, due to collision processes. The negative particles, i. e. ions and electrons, will be extracted by an applied voltage of about 35 kV (the nominal SNS beam energy for injection into the RFQ accelerator is 65 keV), and most of the extracted electrons are deflected by a dedicated magnetic dipole field and deposited inside a ‘dumping’ electrode.

## TEST RESULTS AND STATUS

As a first test, the SNS ion source was operated alone, in the standard mode with pulsed 2 MHz rf power, 13.56 MHz cw power to facilitate pulse ignition, and a capacitive impedance matcher [16]. An H<sup>-</sup> beam current of about 15 mA was measured in the two-chamber Faraday cup, even without cesiation of the collar, and in a test experiment using helium as feeding gas, it was ensured that no extracted electrons were measured in the ion partition of the cup.

In the second phase, the ECR ion source was operated alone on the test stand, and up to 1.5 A electrons were extracted at 2 kW microwave power.

Lastly, with the original HYBRIS configuration [17] the electrons were extracted from the ECR plasma, accelerated to 5 keV energy, and then decelerated to 50 - 250 eV upon injection into the H<sup>-</sup> discharge chamber. The attempt to start a discharge in the H<sup>-</sup> chamber using this approach failed, however, because at pressures where a dc discharge could have been ignited, a plasma formed in the electron extraction gap, shortening out the accelerating power supply and overheating the extractor tube.

During the next attempts to strike a discharge in the main chamber, the ECR body was closely coupled to the discharge cathode flange and biased by up to -150 V against the cathode. The electrical circuitry with nominal power supply ratings is shown in Fig. 2.

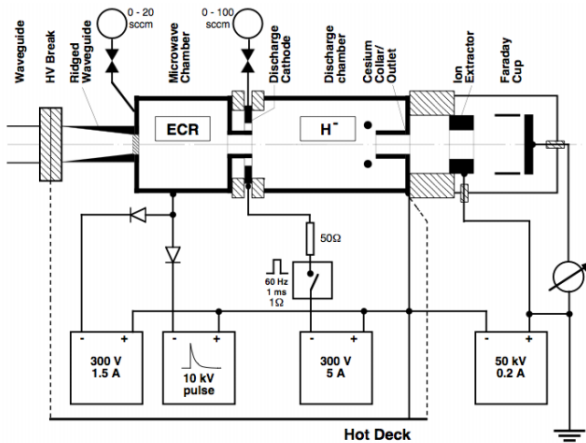

Figure 2: Electrical circuit for HYBRIS.

However, the attempts at forcing ignition failed again. Only when the ECR was operated at the same potential as the cathode could a microwave-assisted discharge be ignited and sustained in the main chamber, and at 1.2 kW of microwave power, the pulse current reached 6 A. Apparently a quasi-neutral plasma needs to be injected into the main chamber to strike the pulsed cold-cathode discharge. All of these preliminary tests were performed with a pulse duration of 0.1 ms and a repetition rate 10 Hz.

For the most recent tests, the mechanical configuration was again modified, eliminating the entire original H<sup>-</sup> chamber cathode flange and the insulator ring, and utilizing the ECR outlet electrode with a stainless steel insert as the discharge cathode. In this set-up the downstream solenoid coil actually overlaps the H<sup>-</sup> discharge, as schematically indicated in Fig. 1, and the ECR resonance surface deeply protrudes into the discharge chamber, allowing a more intense flow of plasma to reach the main discharge region.

With 1.5 kW microwave power, a peak discharge current of 12 A was reached, and the duty factor was gradually raised to 6.6% (1.1 ms duration and 60 Hz repetition rate), exceeding the nominal SNS duty factor. The discharge pulses stayed perfectly flat for all pulse lengths between 0.1 and 1 ms, and the amplitude remained unchanged. No hard performance limit was yet encountered.

## SUMMARY AND OUTLOOK

A novel concept for a hybrid H<sup>-</sup> ion source has been devised, operating the discharge in pulsed dc mode and utilizing a microwave-driven plasma cathode. Initial tests of the major components, i. e. plasma cathode and multicusp H<sup>-</sup> ion source operated with rf power, have been successfully performed, and a microwave-sustained pulsed dc discharge was created, but the actual production of H<sup>-</sup> ions has not yet been investigated. Once the proof-of-principle can be regarded as successful, there are three lines of future developments envisaged:

- Exploring the limits of H<sup>-</sup> ion beam production in this novel way, including cesiation of the source collar.
- Improving the packaging of the assembly to make it into a robust injector component.
- Developing a removal system for the beam electrons at intermediate beam energy, expanding on a concept proposed in Ref. [18], to avoid electron deposition on the extractor electrode, in conjunction with developing a new Low Energy Beam Transport section.

## REFERENCES

[1] T. Mason, "The Spallation Neutron Source: A Powerful Tool for Materials Research," Proc. Int. Workshop ICFA-HB, Bensheim, Germany, Oct. 2004.  
 [2] R. Keller, R. Thomae, M. Stockli, and R. Welton, "Design, Operational Experiences and Beam Results

Obtained with the SNS H<sup>-</sup> Ion Source and LEBT at Berkeley Lab," AIP Conf. Proc. **639**, New York: American Institute of Physics, 2002, pp. 47-60.

[3] R. F. Welton, M. P. Stockli, S. N. Murray, and R. Keller, "The status of the spallation neutron source ion source," Rev. Scientific Instrum. Vol. **75** (5), 1793-1795 (2004).  
 [4] T. Taylor and J. F. Mouris, "An advanced high-current low-emittance dc microwave proton source," Nucl. Instr. Methods **A 336**, 1 (1993).  
 [5] J. D. Sherman et al., "A 75-keV, 145-mA Proton Injector, Rev. Sci. Instrum. **73** (2), 917-921 (2002).  
 [6] R. Gobin et al., "High intensity ECR ion source (H<sup>+</sup>, D<sup>+</sup>, H<sup>-</sup> developments at CEA/Saclay," Rev. Sci. Instruments **7** (2), 922-924 (2002).  
 [7] Assistance by J. Nolen, R. Pardo, and R. Scott of Argonne Nat. Lab. is thankfully acknowledged.  
 [8] M. von Ardenne, Tabellen zur Angewandten Physik, Vol. 1 (in German), Berlin: VEB Verlag der Wissenschaften, 1962, p. 653 and H. Froehlich, Nukleonik **1**, 183 (1959).  
 [9] P. Briand, R. Geller, B. Jacquot, and C. Jacquot, Nucl. Instrum. Methods **131**, 407 (1975).  
 [10] R. Keller, "High Current Gaseous Ion Sources" in The Physics and Technology of Ion Sources edited by I.G. Brown, New York: John Wiley, 1<sup>st</sup> edit. 1989, p.161.  
 [11] D. Spence, K. R. Lykke, and G. E. McMichael, "Plasma Modified Production of High-current, high-purity cw H<sup>+</sup>, D<sup>+</sup> and H<sup>-</sup> beams from Microwave-driven Sources," Proc. Linac '96, Paper MOP10 (1996).  
 [12] K. Jayamanna, D. Yuan, T. Kuo, M. McDonald, P. W. Schmor, and G. Dutto, "Microwave-driven multipurpose ion source," Rev. Sci. Instrum. **67** (3), 1061-1063 (1996).  
 [13] R. Gobin, O. Delferrière, R. Ferdinand, F. Harrault, K. Benmeziane, G. Gousset, and J. D. Sherman, "Development of an H<sup>-</sup> ion source based on ECR plasma generator at CEA/Saclay," Rev. Sci. Instrum. **75** (5), 1741-1743 (2003).  
 [14] Y. Matsubara, H. Tahara, and S. Nogawa, "Development of microwave plasma cathode for ion source," Rev. Sc. Instrum. **61** (1) 541-543 (1990).  
 [15] K. N. Leung, K. W. Ehlers, and M. Bacal, Rev. Sci. Instrum. **54**, 56 (1983).  
 [16] J. W. Staples, "High-efficiency Matching Network for RF-Driven Ion source," Proc. 2001 Particle Accelerator Conf., Chicago, paper WPAH 014 (2001).  
 [17] R. Keller P. Luft, M. Regis, J. Wallig, M. Monroy, A. Ratti, D. Syversrud, R. Welton, and D. Anderson, "A Hybrid Ion-Source Concept for a Proton Driver Front-End," Proc. Int. Workshop ICFA-HB2004, Bensheim, Germany, Oct. 2004.  
 [18] M. Tanaka et al., "Investigation of beam deflection reduction and multi-beamlet focus at a large-area negative ion source for a neutral beam injector with 3-D beam trajectory simulation," Nucl. Instrum. Methods in Phys. Res. **A449**, 22-35 (2000).