

# HIGH POWER TESTING OF INPUT COUPLERS FOR SUPERKEKB

H. Sakai, T. Kageyama, T. Abe, and Y. Takeuchi  
 KEK, Oho 1-1, Tsukuba, Ibaraki 305-0801 Japan

## Abstract

At KEKB, 32 ARES cavities have been successfully operated to store stably high-current electron and positron beams. Currently, 300 kW or more of RF power (freq. = 508.887 MHz) is fed to each ARES cavity through a coaxial-type input coupler. The design power capability of the input coupler is 400 kW at maximum for KEKB, and needs to be increased to 800 kW for SuperKEKB. Recently, we have constructed a new test stand to simulate the actual operating condition over 800 kW for the input coupler to drive the ARES cavity loaded with beam. This article reports the key features of the new test stand together with the recent results of high-power test.

## INTRODUCTION

The ARES cavity is a three-cavity system stabilized with a  $\pi/2$ -mode operation [1], where an accelerating cavity is coupled with a large cylindrical high-Q energy storage cavity via a coupling cavity between. Its design is based on a high-power conceptual demonstrator ARES96 [2] with a cylindrical energy storage cavity operated in the TE013 mode. The input coupler is an important accessory device through which the RF power is fed into the cavity, and also has a ceramic window to separate the vacuum from the atmosphere. Figure 1 shows a schematic drawing of the input coupler [3] used for the ARES cavity system at KEKB. The RF power coming through the rectangular waveguide of WR1500 is transferred via a doorknob transition with a capacitive iris at the entrance, to the coaxial line of WX152D with a disk-type ceramic window where the coaxial line is over- and under-cut for impedance matching. Further, the coaxial line is tapered and reduced to a straight section of WX77D, and finally terminated with a magnetic coupling loop. When driving the ARES cavity, the input coupler is to be attached to one of the three circular ports at the middle level of the cylindrical side of the storage cavity. The design power capability of the input coupler is 400 kW at maximum for KEKB, and needs to be increased to 800 kW for SuperKEKB [4].

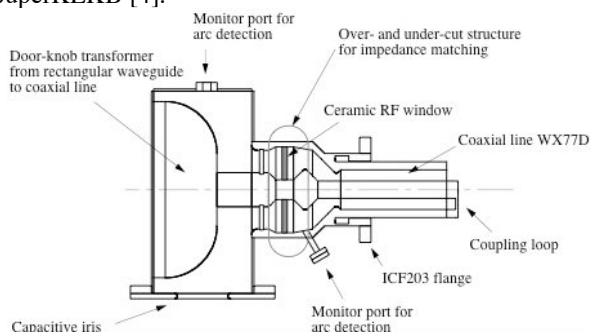

Figure 1: Input coupler for the KEKB ARES cavity.

## OLD SETUPS FOR KEKB

The method of high-power testing or RF-processing of the input coupler has evolved into the present one in three steps. Two old setups for the KEKB purpose are briefly reviewed in the following subsections.

### The First Method: Through-Combination Setup

Most of the input couplers produced for KEKB were RF-processed with a through-combination setup of two couplers, as shown in Figure 2, where the two coupling loops were facing and electromagnetically coupled with each other in a two-port cylindrical vacuum chamber. The RF power went through those two couplers and dissipated in a 1-MW water load of the rectangular waveguide-type.

The through-combination setup is simple and compact. However, the smallness of its vacuum volume with a poor conductance sometimes allowed the vacuum pressure to rise fast before the RF power turned off, and consequently the electric discharge or arcing to develop to catastrophic levels. Actually, some couplers failed to pass the high power test up to the KEKB design power of 400 kW because its metal (or ceramic) surfaces were severely damaged during the RF processing. Another disadvantage is that the through-combination setup is different from the actual operating condition for the input coupler to drive the ARES cavity. In advance of the coupler production for KEKB, some prototype couplers had been successfully tested up to 950 kW with the through-combination setup. However, strictly speaking, even those encouraging results might not allow us to claim that the current input coupler has been fully qualified for SuperKEKB.

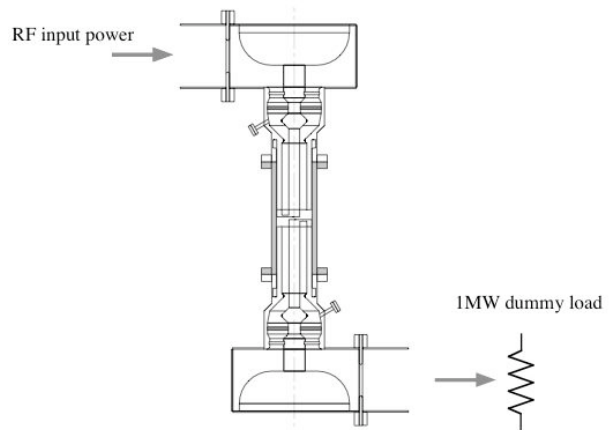

Figure 2: Through-combination of two input couplers.

### The Second Method with a Storage Cavity

Figure 3 shows a schematic drawing of the second setup with use of a storage cavity as the RF load. One of the storage cavities in reserve was used. A box-shaped structure for the  $\pi/2$ -mode termination was attached to the

rectangular flange, to which the coupling cavity is to be connected for the full setup of the ARES cavity system. The  $\pi/2$ -mode terminator is a water-cooled copper box with a rectangular stainless-steel flange, developed for high-power testing of the storage cavity, itself. The input coupler to be tested was attached to one of the three driving ports with a coupling factor of about 3, nearly equal to that for driving the ARES cavity at KEKB.

This setup had the following advantages. First, the vacuum conductance was greatly improved in comparison with the previous through-combination setup, since the coaxial line part was open to the large volume of the storage cavity pumped out with a turbo molecular pump and two ion pumps. Actually, two couplers, which had failed in RF processing with the through-combination setup, were successfully re-conditioned up to 400 kW. Next, this setup enabled the precise study of the multipactoring discharge in the coaxial line of the input coupler [5]. A TV camera was attached to the opposite driving port in order to monitor the coaxial line. In addition, the storage cavity, itself, operated in the TE013 mode is almost free from multipactoring discharge. Therefore, we were able to obtain exact responses of the vacuum pressure to the multipactoring discharge in the coaxial line.

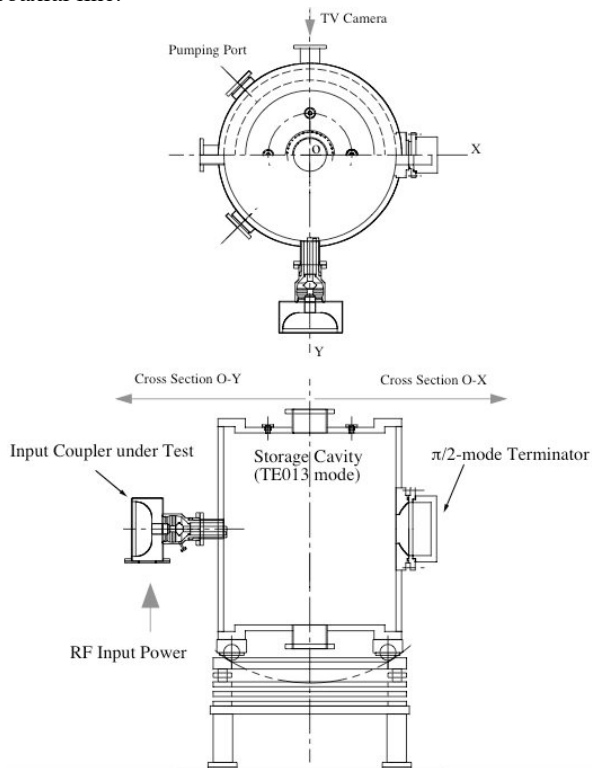

Figure 3: Setup using a storage cavity. Plan (top) and side (bottom) views are shown.

### NEW SETUP FOR SUPERKEKB

The only disadvantage of the second setup with use of a storage cavity was that the RF input power was limited to 500 kW at maximum. This limit was due to an enormous wall power dissipation of over 300 kW for the storage

cavity, more than three times larger than the design wall power of 90 kW. Needless to say, the flow rate of the cooling water was necessarily increased from 150 L/min (design) to 300 L/min. The limit of the RF input power has been resolved as follows.

### The Third Method

Figure 4 schematically shows the third setup currently used for the SuperKEKB R&D. An input coupler to be tested and a TV camera monitoring the coaxial line are attached to the storage cavity in the same manner as the second setup. Another input coupler is attached to the third driving port as an output coupler. The third driving port is located opposite to the rectangular flange, to which the  $\pi/2$ -mode terminator is attached. The extracted RF power through the output coupler is dissipated in the 1-MW water load used in the through-combination setup. By changing the coupling factor of the output coupler to the storage cavity, the ratio of the extracted RF power to the wall power can be adjusted to be nearly equal to that of the beam power to the cavity wall power for the case of SuperKEKB. Therefore, in addition to the advantages of the second setup, the new setup enables high power testing of the input coupler under almost the same condition as will be seen at SuperKEKB.

Figure 5 shows a photo of the high power test setup, where two spare couplers of the same type for KEKB were attached to the storage cavity. This setup was constructed as follows. First, the input coupler to be tested was attached to the driving port at the right side in Fig. 5, and the coupling factor was set to 4, the same as for the SuperKEKB design. Next, the other input coupler, which had been conditioned in advance together with the storage cavity, was attached to the driving port at the left side as the output coupler. The coupling of the output coupler was adjusted so as to match the input coupler to the storage cavity loaded with the 1-MW water load. Then, the extracted RF power became three times as large as the wall power of the storage cavity.

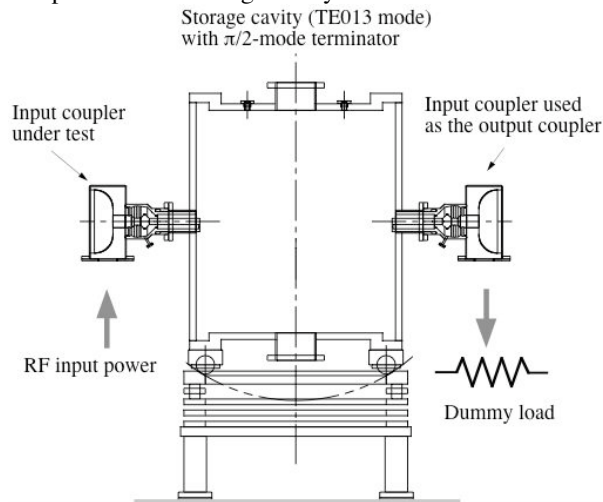

Figure 4: New setup using a storage cavity for high-power testing over 800 kW, where another coupler is attached and the extracted RF power is dissipated in a dummy load.

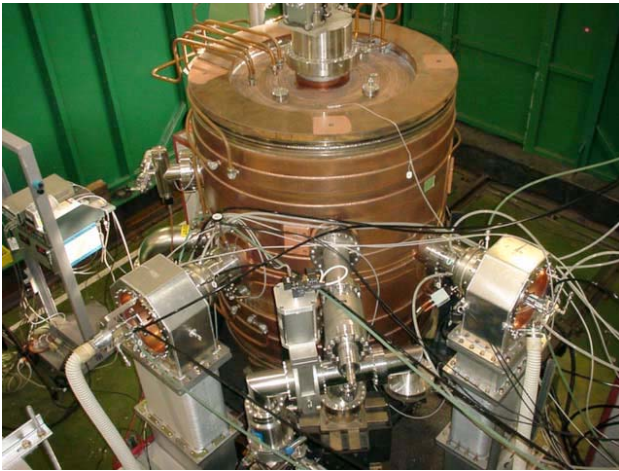

Figure 5: Two input couplers of the same type for KEKB use are attached to the storage cavity. One (right) is under test and the other (left) used as the output coupler.

### High Power Test and Results

The RF conditioning was automatically carried out with use of a PC-based control system, keeping the vacuum pressure below a specified limit. Considering the pressure rise due to the cavity wall temperature rise, the limit was necessarily raised step by step from  $5 \times 10^{-8}$  to  $2 \times 10^{-7}$  Torr. The RF output power from a 1-MW CW klystron (Toshiba E3732) was measured with a directional coupler, while the cavity wall power and the power dissipation in the water load were calorimetrically measured. Those three measurements were consistent with one another within a reasonable error. The VSWR of the water load, monitored with a bi-directional coupler, was always below 1.05 during the test. The reflection power from the input coupler was always monitored with a directional coupler, and the detected signal was fed into a discriminator as the fast interlock. For each coupler, a photodiode sensor for arc fault detection was attached to a small port viewing the vacuum side of the RF window, which is to be protected against catastrophic arcing failures.

Figure 6 shows the history curve of the high power test, where the RF input power is plotted as a function of net conditioning time, not elapsed time. The input coupler was successfully conditioned up to 820 kW in only 8 hours. During the RF conditioning, we observed light emission in dark blue in the coaxial line at RF input power levels of 380, 540, and 640 kW. Fortunately for this input coupler, those symptoms, probably due to the electron multipactoring discharge in the coaxial line, have completely disappeared after the RF conditioning.

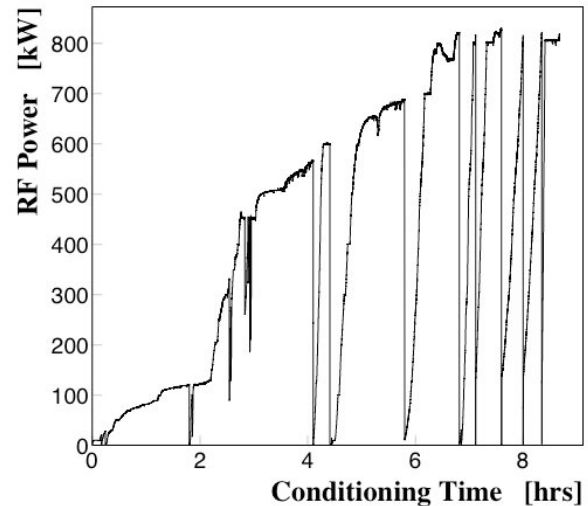

Figure 6: History curve of the high power test with the new setup: an input coupler of the current KEKB version was successfully conditioned up to 820 kW.

### SUMMARY

We have constructed a new test stand for high power testing of input couplers for the ARES cavity system, especially aiming at SuperKEKB. The new test stand, consisting of a storage cavity loaded with a 1-MW water load, enables the high power testing of the input coupler under almost the same operating condition as will be seen at SuperKEKB. Recently, we have demonstrated that the current version of the input coupler for KEKB has already enough capability to feed stably more than 800 kW of RF power to the ARES cavity.

### REFERENCES

- [1] Y. Yamazaki and T. Kageyama, "Three-Cavity System which Suppresses the Coupled-Bunch Instability Associated with The Accelerating Mode", Part. Accel. 44, p. 107, 1994.
- [2] T. Kageyama et al., "Development of High-Power ARES Cavities", Proc. PAC97, Vancouver, 1997.
- [3] F. Naito et al., "The Input Coupler for the KEKB ARES Cavity", Proc. APAC98, Tsukuba, 1998.
- [4] SuperKEKB Task Force, "Letter of Intent for KEK Super B Factory", KEK Report 2004-4, June 2004.
- [5] T. Abe et al., "Development of RF Input Coupler with a Coaxial Line TiN-Coated against Multipactoring", TPPT006, this conference, 2005.