

## THE LHC BEAM LOSS MEASUREMENT SYSTEM

B. Dehning, E. Effinger, J. Emery, G. Ferioli, G. Guaglio,  
E. B. Holzer, D. Kramer, L. Ponce, V. Prieto, M. Stockner,  
C. Zamantzas, CERN, Geneva, Switzerland

### Abstract

An unprecedented amount of energy will be stored in the circulating beams of LHC. The loss of even a very small fraction of a beam may induce a quench in the superconducting magnets or cause physical damage to machine components. A fast (one turn) loss of  $3 \cdot 10^{-9}$  and a constant loss of  $3 \cdot 10^{-12}$  times the nominal beam intensity can quench a dipole magnet. A fast loss of  $3 \cdot 10^{-6}$  times nominal beam intensity can damage a magnet. The stored energy in the LHC beam is a factor of 200 (or more) higher than in existing hadron machines with superconducting magnets (HERA, TEVATRON, RHIC), while the quench levels of the LHC magnets are a factor of about 5 to 20 lower than the quench levels of these machines. To comply with these requirements the detectors, ionisation chambers and secondary emission monitors are designed very reliable with a large operational range. Several stages of the acquisition chain are doubled and frequent functionality tests are automatically executed. The failure probabilities of single components were identified and optimised. First measurements show the large dynamic range of the system.

### ARCHITECTURE OF THE BLM SYSTEM

#### Detectors



Figure 1: Photograph of the inside of an ionisation chamber. The stack of aluminum electrodes with the insulator ceramics at both ends can be seen.

Signal speed and robustness against aging were the main design criteria for the detectors. Due to the high dynamic range two types of detectors will be used. The standard monitors are ionisation chambers with parallel aluminum electrode plates separated by 0.5 cm, as shown in Figure 1. The detectors are 50 cm long with a diameter of 9 cm and a sensitive volume of 1.5 liter. The collection time of the electrons and ions is of the order of 300 ns and 80  $\mu$ s respectively. The chambers are filled with N<sub>2</sub> at 100 mbar overpressure. The composition of the chamber gas is the only component in the BLM system which is not remotely monitored. In order to overcome this limitation the properties of the chamber gas were chosen to be sufficiently close

to air at ambient pressure (i.e. inside a detector which has developed a leak) not to compromise the precision of the BLM system, but sufficiently different to detect a leak during the scheduled annual test of all the chambers with a radioactive source.

At locations with very high (potential) loss rates (about 300) the ionisation chambers will be complemented by secondary emission monitors (see Figure 2). They are based

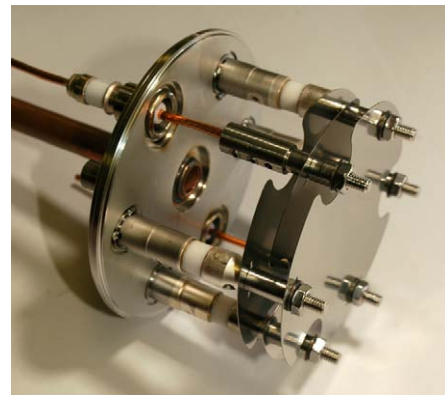

Figure 2: Photograph of the inside of a secondary emission detector. The stack of two aluminium and one titanium electrodes are mounted with insulating support.

on the same design, but hold only three electrodes. The signal (middle) electrode is made out of titanium, because its secondary emission coefficient shows better stability to the integrated dose increases [1]. This chamber is 10 cm long, and pressure inside has to stay below  $10^{-7}$  bar. To keep the vacuum over the foreseen life span of 20 years a NEG pumping strip of 300  $cm^2$  is mounted inside the container. The sensitivity is about a factor of  $3 \cdot 10^4$  smaller than in the ionisation chamber.

Both chambers are operated at 1.5 kV and are equipped with a low pass filter at the high voltage input. The combined dynamic range of the detectors is higher than  $10^9$ . It is limited for the ionisation chamber by leakage currents through the insulator ceramics at the lower end and by saturation due to space charge at the upper end. The lower end limitation for the secondary emission detector is given by parasitic ionisation outside of the chamber at the location of feedthroughs and connectors. The high end limitations are unknown.

The estimated radiation dose on the detectors during 20 years of LHC operation is  $2 \cdot 10^8$  Gray in the collimation

T03 Beam Diagnostics and Instrumentation

1-4244-0917-9/07/\$25.00 ©2007 IEEE

sections and  $2 \cdot 10^4$  Gray at the other locations. To minimise the radiation aging effects (etc. electronegative gases, organic compounds) a strict cleaning procedure for the chambers is followed (including glow discharge cleaning for the collimation section detectors). Impurity levels due to thermal and radiation induced desorption are estimated to stay in the ppm range. No organic material is present, neither in the production process (pumping, baking and filling) of the detectors, nor in the detectors themselves.

The positioning of the detectors was determined by simulation studies. In the arcs, three monitors per beam will be installed around each quadrupole located in the horizontal plane defined by the beam vacuum tubes (see Figure 3). At this position the secondary particle fluence is highest and the best separation of the losses from the two beams is reached. Their longitudinal positions are about 1 m downstream of the most likely loss locations.



Figure 3: The location of the BLMs outside of the cryostat at the plane of the vacuum chambers. At the LHC arc two detectors are on the quadrupole magnets (white) and one on the adjacent bending magnet (blue).

### Acquisition System

The electrical signals of the detectors are digitized with a current to frequency converter and these pulses are counted over a period of  $40 \mu s$  (see Figure 4). The counter value is transmitted every  $40 \mu s$  to the surface analysis electronics using a high speed optical link (with a cyclic redundancy check). The signal treatment and transmission chain is doubled after the current to frequency conversion to meet the required failure rate probability of  $10^{-7}$  to  $10^{-8}$  per hour. The surface electronics calculates the integrated loss values and compares them to a table of loss duration and beam energy depended threshold values. Warning information is transmitted by a software protocol. The beam abort signals are transmitted to the beam dump kicker magnets using the LHC beam interlock system (LBIS). The beam energy information is received over a dedicated fiber link. Details to the readout system can be found in [2] and [5].

The analog electronics is located below the quadrupole magnets in the arc. For all detectors of the dispersion suppressor and the long straight sections the electronics is located in side tunnels to the LHC. All components of the tunnel electronics are radiation certified to 500 Gray. The

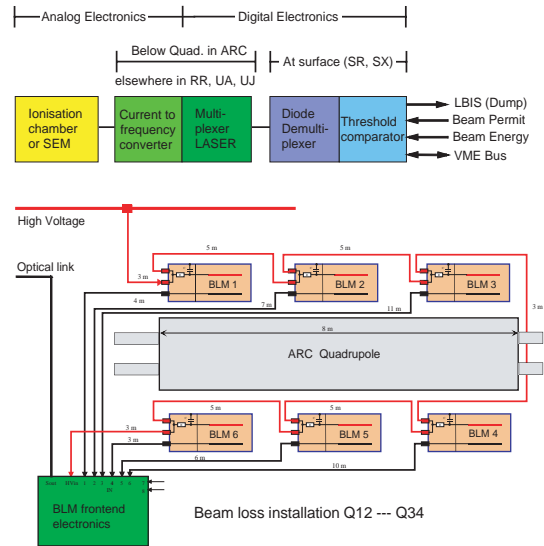

Figure 4: Schematic view of the signal transmission chain and the BLM installation around one arc quadrupole.

dose expected at the electronics locations is about 20 Gray per year. The analog signal transmission cables have a length of a few meters in the LHC arcs and up to 500 m in the long straight sections. This part of the transmission is subject to the injection of electromagnetic crosstalk and noise.

The availability of all electronics channels is constantly monitored and radiation dose induced drifts in the electronic channels are corrected (up to a maximum level, which corresponds to 10% of the lowest beam abort threshold value). The availability of all detectors, the acquisition chains and the generation and communication of the beam abort signal is verified for each channel before each injection into the LHC.

The BLM system will drive an online event display and write extensive online logging (at a rate of 1 Hz) and post-mortem data (up to 20000 turns plus averages of up to 10 minutes) to a database for offline analysis.

### Failure Rate and Availability

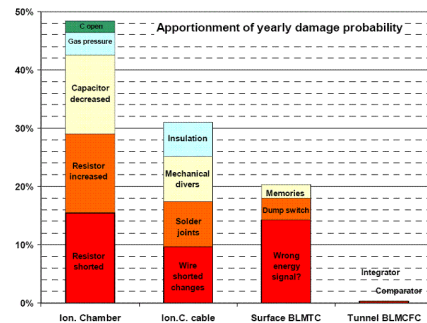

Figure 5: Relative probability of a system component being responsible for a damage to a LHC magnet in the case of a loss.

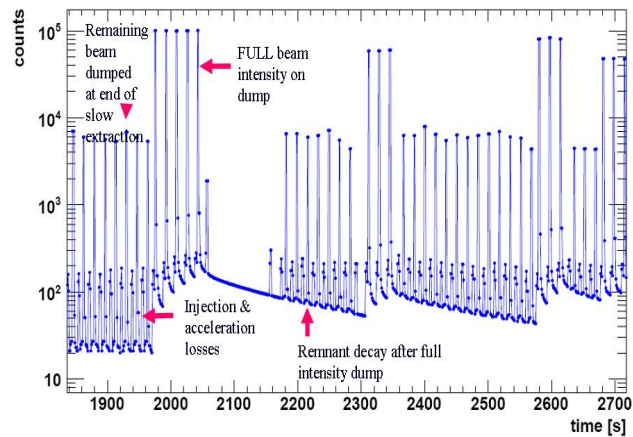

Figure 6: Loss measurements as function of time at the SPS beam dump.

The measurement system failure rate and the availability requirements have been evaluated using the Safety Integrity Level (SIL) approach [4]. A downtime cost evaluation is used as input for the SIL approach. The beam loss monitor system's response is critical for short and intense particle losses, while at medium and longer loss durations it is assisted by the quench protection system and the cryogenic system. The required probability of not detecting a dangerous beam loss, and therefore losing a magnet, is  $10^{-3}$  per year, which corresponds to SIL3. The unavailability of the BLM system has been calculated (using the program Reliability Workbench V10.0, ISOGRAPH) to be  $5 \cdot 10^{-6}$  per channel. Assuming 100 dangerous losses per year satisfies the SIL3 requirement, the required probability of generating a false dump is calculated to be  $10^{-6}$  to  $10^{-7}$  per hour (SIL 2) per channel. This corresponds to 20 false dumps per year. The simulation of the BLM system yields 10 to 17 false beam aborts per year, again satisfying the SIL2 requirement. A detailed record of the reliability calculations for the BLM system and for the whole LHC can be found in [3, 5] and [6] respectively.

To identify the weakness of safety system components a relative comparison is shown in Figure 5. In the LHC design the ionisation chambers and their cabling contributes most to the un-safety of the system. Even with no damage in 30 years of the ionisation chamber operation, systems which are redundant and frequently checked, contribute less to the un-safety. The availability of the system is decreased by false dumps. The components of the beam loss system which are most responsible for these dumps are located in the very front end of the signal treatment chain, which are not redundant. For the LHC design that is the discharge switch of the integrator in the current to frequency converter.

## TEST MEASUREMENTS

The complete system is being tested at HERA (DESY) and SPS (CERN) beam dumps. At HERA mainly the shower simulation are checked and at the SPS a comparison will be done between the ionisation chambers and the sec-

ondary emission detectors. The SPS allows to test the detectors over a large dynamic range with a pulsed beam (see Figure 6). At 1900 seconds the evolution of radiation at the dump is seen under nominal fixed target operation. At 2050 s the full beam is dumped intentionally showing immediately an increase in the remnant radiation level which is steadily decaying with time. These plots illustrate the appearing radiation level ranging over 4 orders of magnitude.

## REFERENCES

- [1] G. Ferioli and R. Jung, "Evolution of the secondary emission efficiencies of various materials measured in the CERN SPS secondary beam lines", CERN-SL-97-71-BI, 1997.  
D. Kramer, "Secondary Electron Emission Beam Loss Monitor for LHC", DIPAC 2007, Venice, Italy, 2007.
- [2] W. Friesenbichler, "Development of the Readout Electronics for the Beam Loss Monitors of the LHC," CERN-THESIS-2002-028, 2002.  
E. Effinger et al. "Single Gain Radiation Tolerant LHC Beam Loss Acquisition Card", DIPAC 2007, Venice, Italy, 2007.  
C. Zamantzas, "The LHC beam loss monitoring system's real-time data analysis card," CERN-AB-2005-082, DIPAC 05, Lyon, France, 2005.  
C. Zamantzas, "The Design, Construction, Test and Integration of the LHC Beam Loss Monitor Threshold Comparator," unpublished, PhD Thesis, Brunel University, London, UK, 2006.
- [3] G. Guaglio, B. Dehning and C. Santoni, "Reliability of LHC Beam Loss Monitors System for the Large Hadron Collider", ICFA HB2004, Bensheim, Germany; AIP Conf.Proc.773:191-196, 2005.
- [4] "Functional Safety Of Electrical/Electronic/Programmable Electronic Safety Related Systems", IEC 61508 First edition 1998-11.
- [5] G. Guaglio, "Reliability of the Beam Loss Monitor System for the Large Hadron Collider at CERN," unpublished, PhD Thesis, Université Clermont Ferrand II - Blaise Pascal, CERN-THESIS-2006-012.
- [6] R. Filippini et al., "Reliability Assessment of the LHC Machine Protection System", CERN-LHC-Project-Report-812, PAC 05, Knoxville, Tennessee, USA, 2005.