

OPERATIONAL EXPERIENCE WITH TWO TYPES OF 2 MW HVDC POWER SUPPLIES ON LEDA.*

J. Bradley III, D. Rees, R. Przeklasa, Los Alamos National Laboratory, New Mexico;
 R. Jaitly, G. Schofield, Maxwell Technologies;
 M. Scott, Continental Electronics

Abstract

The high voltage DC power supplies are predicted to be the most expensive component of the accelerator at the Accelerator Production of Tritium (APT) plant. Two different types of candidate HV power supplies are being tested on the Low Energy Demonstration Accelerator (LEDA) at Los Alamos National Laboratory. The first type uses SCRs in a twelve pulse topology with a spark gap crowbar. The second type uses IGBTs in a Solid State Modulator topology without a crowbar. While both topologies have been proven in existing high voltage applications, both systems contain new features to improve performance and reliability that have advanced the state of the art in HVDC power supply design. LEDA is being used demonstrate the benefits of these features for the APT plant and evaluate their impact on power supply reliability, serviceability and cost. We present detailed measurements of total power supply efficiency and the effect each topology has on the power factor and harmonic input currents drawn from the local power distribution system in addition to operational performance with other accelerator systems.

1 INTRODUCTION

The requirements, construction and performance of the SCR controlled center tapped High Voltage Power Supply (HVPS) are compared to the requirements, construction and performance of the Insulated Gate Bipolar Transistor (IGBT) controlled Solid State Modulator (SSM) style HVPS.

2 COMPARISON OF REQUIREMENTS

2.1 Performance Requirements

Table 1 shows how the performance requirements for the two types of HVPS systems are similar but not identical. The IGBT controlled HVPS specifications were fixed significantly later than the SCR controlled HVPS specifications. The efficiency, power factor, output voltage regulation and ripple requirements were made more restrictive because the IGBT controlled HVPS topology made tighter requirements more feasible. In this time it was also determined that the allowable energy dissipated in a klystron arc could be increased from 20 to 40 Joules.

The efficiency of the SCR controlled HVPS was specified at full output power. This is not a typical operating point for the klystrons so the efficiency of the IGBT controlled HVPS was specified to be $\geq 97\%$ when

operating at -95 kV at 17 to 21 amps, $\geq 96\%$ when operating between -80 kV and -95 kV at 12 to 21 amps, and $\geq 95\%$ when operating between -60 kV and -80 kV at 10 to 21 amps.

The SCR controlled HVPS input voltage was limited to 1500 V by Los Alamos' decision to use only one SCR per leg in the SCR controller bridge. The IGBT controlled HVPS's input voltage was specified to be 4160 V due to safety constraints at the LEDA facility. The number of input phases was reduced to three to minimize facility cost.

Input current harmonics are a concern because specific harmonics can excite resonances in the power distribution system. For this reason smaller harmonic currents are desirable. The requirements on the input current harmonics for both supplies were determined by IEEE Std 519-1992.

Table 1: HVPS Requirements

Requirement	SCR	IGBT
Output Voltage	0-95 kV	0-95 kV
Output Current	0-21 A	0-21 A
Voltage Regulation	± 770	± 400 V
Voltage Ripple	$< 1540 V_{pp}$	$< 1100 V_{pp}$
Load Arc Energy.	≤ 20 J	≤ 40 J
pf at full power	≥ 0.93	≥ 0.98
efficiency at full power	$\geq 95\%$	$\geq 97\%$
Input Voltage	1500V $\pm 5\%$	4160V $\pm 5\%$
Input phases	6	3
Input current Harmonics	IEEE Std. 519-1992	

2.2 Environmental Requirements

Both power supply types were required to operate in the expected environmental conditions at the Savanna River Site and the environmental conditions at Los Alamos. All components located indoors were required to function over an ambient temperature range of 10°C to 32°C and a humidity range of up to 85% non-condensing. All outdoor components were required to operate over an ambient temperature range of -30°C to 41°C and a humidity range of up to 95% non-condensing. The power supply was required to function at an altitude of up to 2438 m to allow it to be tested at Los Alamos.

2.3 Reliability, Maintenance and Safety Requirements

The Mean Time Between Failure (MTBF) goal for the power supplies was 25,000 hours. This goal was driven by the combination of the MTBF for all other components in each RF system and the number of high power RF systems that are required in the APT plant.

* Work supported by US Department of Energy.

Serviceability was given consideration from the beginning of the power supply design. The goal for the Mean Time To Repair of the supply for all but the most major repairs was one hour or less to reduce the cost of maintaining the APT accelerator.

Kirk® Key locks on the power supplies were required to integrate with the existing Kirk® Key lock system used at the LEDA accelerator. The power supplies were also required to meet all safety requirements at Los Alamos National Laboratory including the requirement that debugging the low level power supply control circuits could be done without exposure to voltages in excess of 24 V.

3 COMPARISON OF CONSTRUCTION

3.1 SCR Controlled Center Tapped Power Supply

The SCR controlled HVPS's were built by Maxwell Laboratories. These supplies utilize an SCR bridge which regulates the current through the center tapped transformer primaries to control the secondary output voltage as shown in Fig. 1. Center point control allows the output voltage filter inductance to be placed across the SCR bridge on the low voltage side of the transformer, which reduces the filter inductor operating voltage. An SCR placed across the inductor is used to dissipate the energy stored within the filter inductor in the event of a klystron arc.

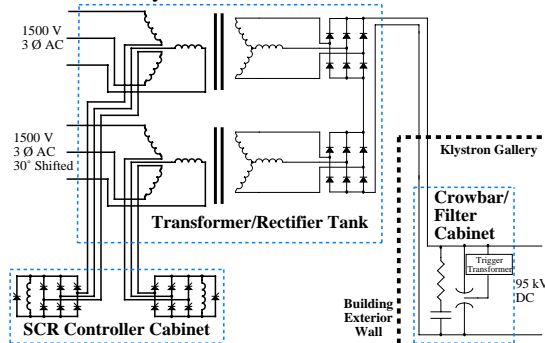

Figure 1: Voltage is controlled by SCR bridges located in the centers of the transformer primaries.

Two sources of 1500 V, 3-phase power are supplied by the unit-substation. One set of 3 phase power is offset by 30° with respect to the other set to produce 12-pulse rectification from two 6-pulse rectifiers whose outputs are wired in series.

The Transformer/Rectifier and SCR controller sub-units are located adjacent to the unit substation, while the Crowbar/Filter sub-unit is located inside the accelerator building adjacent to the klystron. In the event of a klystron arc, the crowbar circuit protects the klystron from stored energy in the filter capacitor and from any power supply follow-through energy.

3.2 IGBT Controlled SSM Style Power Supply

The second power supply type that has been built for LEDA is the IGBT controlled SSM style power supply made by Continental Electronics. The power supply design is based on the Solid State Modulators that are

currently produced for AM radio service. Figure 2 shows how these supplies utilize 96 separate rectifying modules wired in series to produce high voltage. Each module is connected to a unique isolated 3-phase secondary on one of the four transformers as shown in Fig. 3. The relative phase differences between the sets of 3-phase secondaries on each of the four transformers are arranged to achieve 24-pulse rectification at the output.

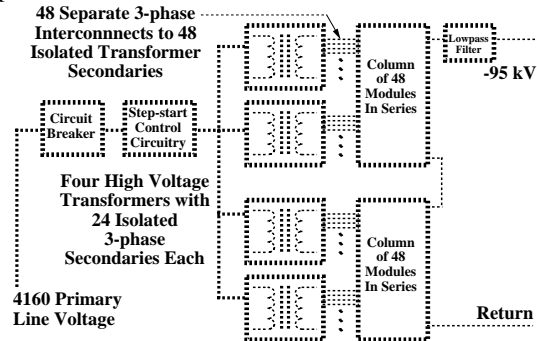

Figure 2: Two transformers serve each power column.

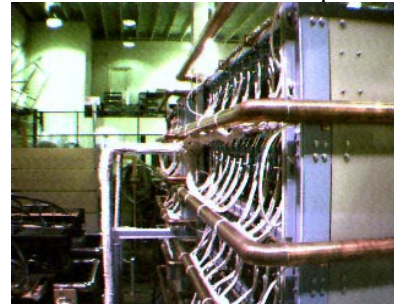

Figure 3: Each module in a power column is connected to one of 96 isolated secondaries.

An IGBT is used on each module for current control as shown in Fig. 4, eliminating the need for a crowbar. A diode allows current produced by other modules to pass through when the IGBT is turned off. The control system cycles through the array of modules to evenly load each module in the system. Each module contains independent control circuitry to monitor the module output and inhibit the three SCRs in the six pulse bridge in the event that the IGBT fails closed. Failed modules are bypassed by the control system to provide graceful degradation of operation. If more than five modules have failed, then the maximum voltage the supply can produce under the condition of 5% input voltage droop is reduced by roughly 1 kV per failed module after the first five.

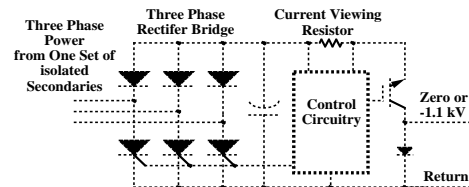

Figure 4: Each module contains a six pulse rectifier.

The power supply is contained within a 6.5 by 5.5 m fenced enclosure. Each module is built on a removable circuit card. The circuit cards are arranged in the two power columns in four rows of twelve. This

arrangement allows cooling air to be blown up the columns and across each module. The columns support corona rings on each row to grade the electric field as the potential increases toward the top of the column. The backplanes of the power columns contain connections to the 96 isolated 3-phase secondaries on each of the four transformers as shown in Figure 3. The backplanes also contain the shorting mechanisms which insure that all modules are discharged when the fenced enclosure is opened.

4 COMPARISON OF PERFORMANCE

4.1 Installation and Facility Requirements

The practical issues involving power supply installation and facility requirements become significant when over a hundred power supplies are to be installed in a short period of time. All the components in the IGBT controlled HVPS are located in one indoor location which covers 36 square meters. The SCR controlled HVPS has a smaller indoor footprint because the largest of the three major sub-units is located outdoors. The cost of the larger indoor area required by the IGBT controlled power supply must be compared to the cost of making and maintaining the interconnections between the sub-units of the SCR controlled HVPS.

4.2 Output Parameters

Both power supplies performed within their requirements for voltage regulation, ripple and load arc energy. The measured values are shown in Table 2.

Table 2: Measured Output Values

Measured Value	SCR	IGBT
Voltage Regulation	± 500 V	± 400 V
Voltage Ripple	< 500 V _{pp}	< 350 V _{pp}
Load Arc energy	3 J	< 10 J

4.3 Power Factor and Efficiency

Efficiency measurements were calculated by taking the output power, as measured by output voltage and current, divided by the primary input power as measured by the facility power distribution diagnostics. Input power for controls and cooling was not factored into this calculation.

The power factor and efficiency of the SCR controlled HVPS were measured at a typical operating point of 88.3 kV and 18.06 A. This point is determined by the klystron operating parameters and the amount of RF power required by the accelerator. At this output power level the power factor was 0.97 and the efficiency was 94%.

Arcing in the LEDA 2 MW HV resistive test load limited the voltage at which the power factor and efficiency of the IGBT controlled HVPS could be reliably measured at this time. At 50 kV output voltage and 10.6 A of output current the power factor was 0.95 and the efficiency was 95.2%. The power factor and efficiency are expected to improve at higher output power levels as the transformer excitation current and power become a smaller fraction of the total input current and power.

4.4 Input Current Harmonics

The measured harmonic components of the primary input current are shown in Table 3. The SCR controlled HVPS input currents were measured at an output current and voltage of 18 A at 88 kV. The IGBT controlled HVPS currents were measured at an output current and voltage of 10 A at 50 kV.

Table 3: Input Currents at Harmonics of 60 Hz

Harmonic Current Frequency	SCR (% of fund)	IGBT (% of fund)
180 Hz	1.3	6.6
300 Hz	4.4	2.1
420 Hz	5.2	1.6
540 Hz	0.7	0.1
660 Hz	7.7	9.3
780 Hz	9.2	7.7
900 Hz	0.6	0.3

The operation of the IGBT controlled HVPS at roughly half of its typical operating voltage may have caused input harmonic currents were a larger percentage of the fundamental than would be expected in normal operation. With only half of the power modules turned on, it is possible that at any given time only two transformers drew most of the power. This would produce uncanceled input harmonic currents at 660 and 780 Hz.

4.5 Operational Performance

Four SCR controlled HVPS's have been installed and are in use in the LEDA project. The SCR controlled HVPS's have been successfully operated in all weather conditions at Los Alamos and have fully protected the klystrons from damage in more than 100 klystron arcs. No arcing or corona damage has been observed in the 95 kV enclosures or components. Initial installation and startup problems included the replacement of the trigger circuit capacitors due to a manufacturing defect, the redesign of the open circuit voltage control network to reduce the network's operating temperature and the repair of fiber optic connections damaged by nearby construction work.

The first IGBT controlled HVPS has been installed and is presently being tested with the LEDA 2 MW HV resistive test load. It will be connected to LEDA's second 700 MHz klystron at the conclusion of these tests.

5 CONCLUSIONS

The tests that have been conducted indicate that the performance of the two types of power supplies is similar. Arcing within the LEDA 2 MW HV resistive test load limited the performance measurements that could be taken on the IGBT controlled HVPS. Demonstration of the predicted increased efficiency and lowered harmonic currents of the IGBT controlled HVPS will require testing at higher power levels. These tests are scheduled to be conducted in April, 1999.

The SCR controlled HVPS's have proven to be very reliable. The IGBT controlled HVPS's do not yet have sufficient operating hours to evaluate their reliability.