

A SOLID STATE INDUCTION MODULATOR FOR SLAC NLC*

R.L. CASSEL, G.C. PAPPAS, M.N. NGUYEN, J.E. DeLAMARE

Stanford Linear Accelerator Center

Abstract

The Next Linear Collider accelerator proposal at SLAC requires a high efficiency, highly reliable, and low cost pulsed-power modulator to drive the 500 kV, 260A X band klystrons. With a pulse width of less than 1.5 microseconds, it is difficult for the present SLAC type modulator with conventional pulse transformer to have a high efficiency due primarily to the inherently slow rise and fall time of the video pulse. The proposed induction modulator utilizes a pulse transformer similar to an induction accelerator driven by Solid State high voltage IGBTs. The performance of the IGBTs, induction cores and a low voltage model will be discussed as well as the design and construction of a prototype modulator capable of driving up to 8 of the X band klystrons

1.0 Design consideration efficiency, availability & cost

The major problem with the conventional PFN type modulator use at SLAC and around the world for the Next Linear Collider (NLC) is the efficiency of the modulator for short pulse operation. The leakage inductance for the pulse transformer and the stray inductance of the switching circuit inherently limit the rise and fall time of the klystron voltage waveform. To reach the efficiency goals of > 75% for the modulator for the NLC it is necessary to have a rise and fall time of the klystron voltage pulse of less than 200 nsec. With the high voltage of the NLC klystron of 500 kV and large stray capacitance of > 100 pfd per klystron (RC time constant of 200 nsec.) it is difficult to obtain a fast rise time with a matched impedance PFN modulator.

The operational availability of the standard SLAC type modulator is limited by the failure rate of hydrogen thyatron used for switching. In addition thyatron are subject to a high incidents of spontaneous triggering, which effects the overall accelerator availability.

The peak power of thyatron and circuit & PFN impedance limits the practical peak power of a SLAC type modulator to about 300 megawatts peak, or capability of driving more than two NLC klystron at one time. This makes the cost of modulators >100k\$ per klystron for the conventional SLAC modulator expensive to build.

1.2) Configuration Selection

To obtain a low leakage inductance, the pulse transformer configuration selected was the fractional turn transformer

with a one turn secondary. This configuration is similar to an induction accelerator with a conductor in place of the beam. The resulting secondary leakage inductance is extremely low (<1 μhy). The major part of the leakage induction coming from the multiple primary connections and the drivers.

To obtain 500 kV for 1.5 usec. (0.75 volt seconds) with one turn secondary requires a large magnetic core cross sectional area. To drive the core without using a matched PFN requires a switch that can not only turn on fast at high power levels but also turn off. This switching devices now exists in the form of IGBT's (Isolated Gate Bipolar Transistors). IGBT's are now available from several manufactures which can switch on and off in < 100 nsec to power levels of 5 megawatts per device. High voltage devices capable of switch > 10 megawatts for 1.5 μsec. are under development.

The use of one turn secondary fractional turn transformer combined with high current IGBT allows for the driving of 8 klystron with one modulator or approximately 1000 megawatts of power for 1.5 μsec. The larger number of klystrons per modulator reduces the overall cost and size of the modulator. Figure 1.

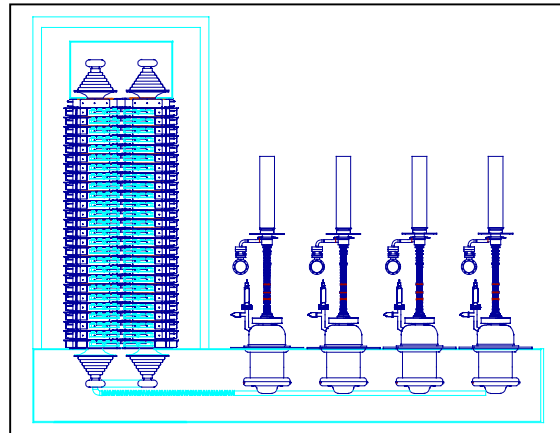

Figure 1. Induction Modulator Layout

1.3 Induction Modulator Specification

• NUMBER OF NLC KLYSTRONS	8 EACH
• OPERATING PULSED VOLTAGE	500 kV
• OPERATING PULSED CURRENT	2120 AMPS
• REPETITION RATE	120 Hz
• VOLTAGE REGULATION FLAT TOP	±1.0 %
• RISE /FALL TIME	<200 nsec
• PULSE DURATION FLAT TOP	1.5 μsec
• ENERGY EFFICIENCY	>75%
• NUMBER SECONDARY TURNS	1

*Work supported Department of Energy contract DE-AC03-76SF515

- NUMBER FRACTIONAL TURNS 104
- NUMBER OF CORE STACKS 4
- NUMBER OF CORE PER STACK 26
- MAGNETIC CORE SIZE 2"H,3.75"W
- VOLTAGE PER CORE 5 kV
- CURRENT PER CORE 2.3 kA
- TOTAL LEAKAGE INDUCTANCE <math><10\mu\text{H}</math>
- SECONDARY STRAY CAPACITANCE <math><400\text{ pfd}</math>

1.4 Transformer Core design

If the efficiency goal is to be obtain the losses in the large core must be small. The core area is set by the volt second requirement and voltage clearance to support the 500 kV pulses. To deduce the core volume and losses, the transformer core will be made of small inside diameter Metglas uncut tape wound cores. Each of the four core stacks has a different inside diameter core to corresponded to a average voltage gradient in the secondary winding oil insulation of <math><250\text{ volts/mill}</math> and a peak gradient of <math><400\text{ volt/mill}</math>. We have been studying different amorphous magnetic materials. The first modulator well be made with AlliedSignal 2605SA1 Metglas because of its availability, however Hitachi FT-1 Finmet or nanocrystalline alloys which are now becoming available may be used to reduces the core losses even further. (Figure 2.)

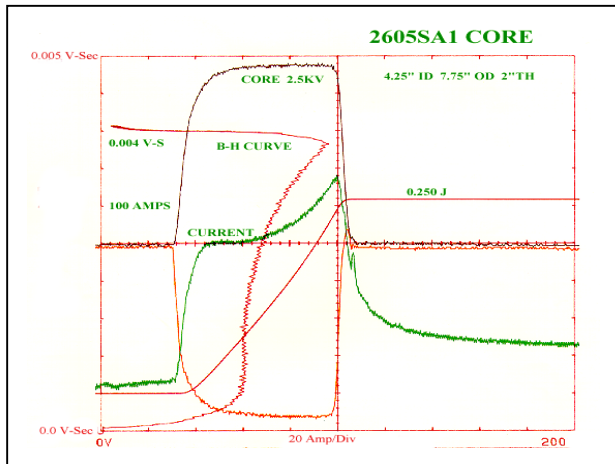

Figure 2. Test Core Magnetising current

1.5 Solid State Drive

With the use of IGBT's the drive for the core is simple, consisting of a DC charge capacitor in series with the IGBT driving the individual magnetic core. A prepared snubber capacitor with fast diode is used across the core to absorb the reflected energy from stray inductance and capacitance under normal and fault conditions. A pulse reset of the core is used to insure that the core is totally reset before the next pulse. The addition of transorbs from collector to gate of the IGBTs absorbs the stray inductive energy of the IGBTs and capacitor in the IGBT during

turn off. The IGBT and its driver are grounded. The energy storage capacitor is charged through the transformer core. A pulse reset circuit consisting of four lower voltage IGBT's resets the core. Figure 3.

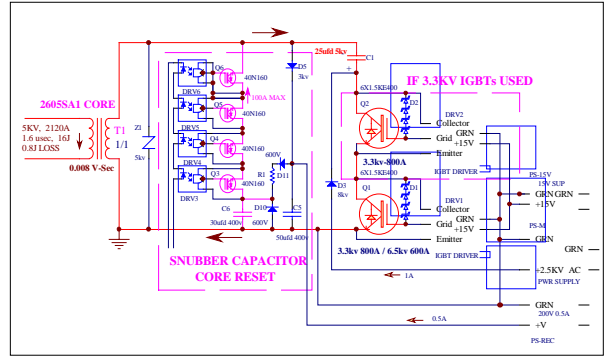

Figure 3. IGBT Drive circuit

We have tested several different IGBTs for turn on and turn off characteristics. The EUPEC FZ800R33KF1 is the best so far. It's turn on and off times are consistent with a 200 ns. rise time of the output pulse. The first prototype modulator well consists of two of the 3.3 KV IGBT in series, to be replaced with one 6.5 kV IGBT when they are available. Figure 4.

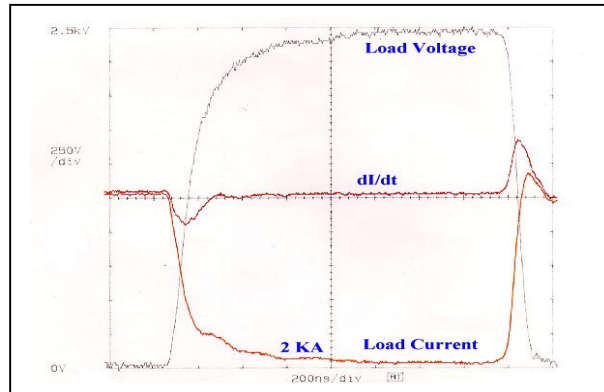

Figure 4. EUPEC FZ800R33KF1 Pulse

The drivers well be mounded on a PC Board in air and arranged so that they can be plugged into the transformer core for easy replacement. Figure 5.

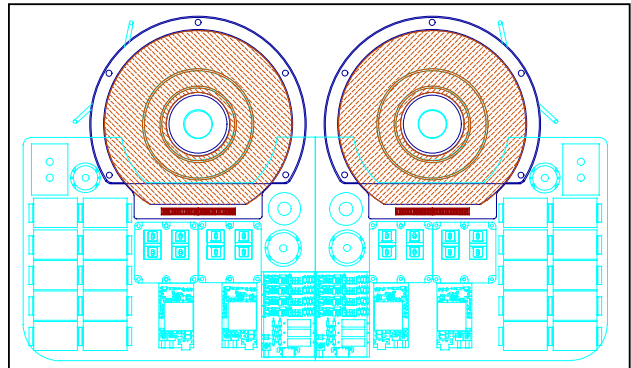

Figure 5. PC Board Core Driver circuit

1.6 Simulations & Calculations

Spice simulations were made on the induction modulator driving eight klystron with a 100 cell induction modulator using the turn on and turn off characteristics of the EUPEC IGBTs. The resulting waveform had a small amount of overshoot ringing. By delaying turn on of less than 20 % of the cells the waveform performance can be improved. Figure 4. The Spice simulations did not adequately take into account the losses introduced by the transformer cores, which should help in reducing the waveform ringing. The resulting rise time was approximately 200 ns. The resulting waveform power efficiency of better than 89%, which indicates the possibility of reaching the 75% efficiency goal. Figure 6.

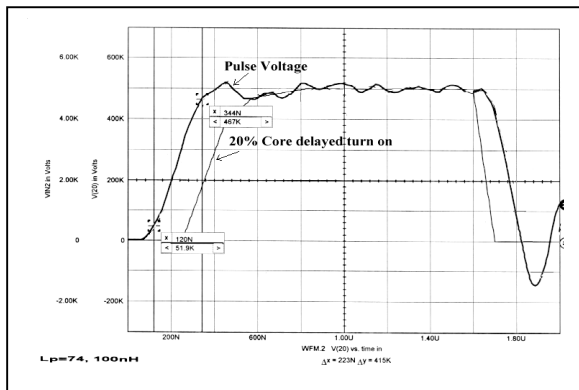

Figure 6. Spice Simulation with Delayed Turn On

1.7 Model of Induction modulator

A model of the induction modulator was fabricated to study the performance of the cores and IGBT's. It consisted of 6 core with 0.004 Volt-Second driven from 6 1700 volt IGBTs. There were 4 secondary turns. In addition there was a saturated core to increase the rise time and lower the IGBT losses. Figure 7.

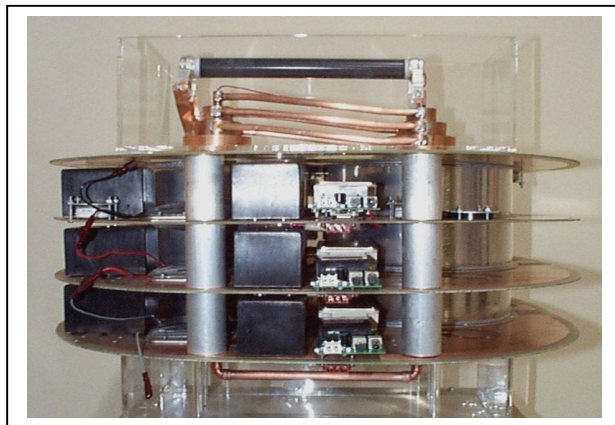

Figure 7. Model Induction Modulator

The model demonstrated that the concept was workable. The total reset of the magnetic cores, allowed for one or more of the IGBTs to be not functional or shorted with only a reduction in the output voltage in the overall performance of the system. Figure 8.

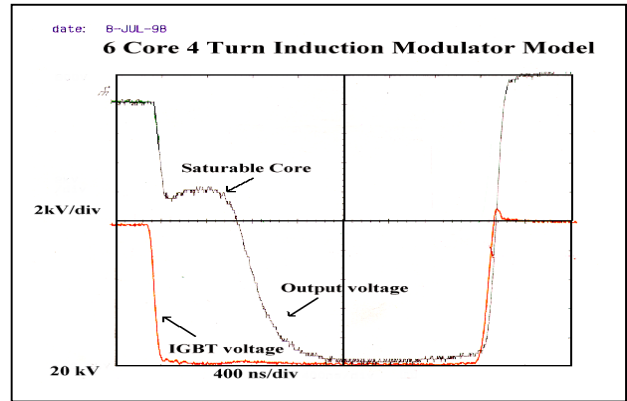

Figure 8. Model Waveform

1.8 Induction modulator advantages

There are several additional advantages of the Solid State induction modulator over the conventional modulator. All of the high voltage parts are inside the transformer core and not exposed. The core drivers are at ground potential with only the IGBTs collector and the capacitor are at moderate voltages. The addition of more driver cells then are required for the 500 kv results in redundancy so that an individual driver or core could fault without effecting the overall operation of the modulator. The pulse duration is only determined by the volt-seconds in the core so that a shorter pulse can be obtained by timing for conditioning of the klystron or accelerator or if operated at a lower voltage a longer pulse is available.

1.9 Conclusions

From the modelling, measurement of core, and IGBT and calculation it appears that the induction modulator is feasible and practical. It has the potential of high efficiency and reliability and low cost. Figure 9.

		joules	120hz watts	100 watts/cell
Total Power 500KV * 2120 A * 1.5 usec		1,590.0	190,800	
Efficiency	76.5%	487.6	58,506	
Pulse wave form (200 nsec)	88.5%	182.9	21,942	
Core loss Total	95.4%	72.4	8,688	87
Power Supply 5Kv 250Kw	95.0%	80.0	9,600	96
Solid State (IGBT + diodes)	95.7%	68.6	8,232	82
Stray impedance	96.3%	58.4	7,008	70
Capacitor & Snubbers	98.4%	25.3	3,036	30
		joules	watts	watts/cell
Total power used		2,077.6	249,306	366

Figure 9. Efficiency Calculation

The R&D on a prototype modulator is underway with a collaboration of SLAC and LLNL to produce a working unit by the end of FY 00.