

MULTIPOLE SPILLDOWN IN THE SPEAR 3 DIPOLE MAGNETS*

J. Corbett[†], D. Dell’Orco, Y. Nosochkov and J. Tanabe
 Stanford Linear Accelerator Center/SSRL, Stanford, CA 94309

Abstract

The main SPEAR 3 dipole magnets are 1.45 m long with a pole contour designed to horizontally deflect and vertically focus the electron beam. At the nominal beam energy (3 GeV), the field and gradient along the magnet centerline are 1.3 T and 3.3 T/m ($k=-0.33 \text{ m}^{-2}$), respectively. Due to the straight core construction, the beam passes through each dipole with up to 16.6 mm trajectory offset relative to the centerline. This paper describes a method used to characterize the spilldown effect from magnetic multipole fields as observed by the beam traversing the dipole magnets. Results of tracking studies utilizing the longitudinal variation of multipole fields are discussed.

1 SPEAR 3 DIPOLE MAGNETS

As illustrated in Fig. 1, the SPEAR 3 dipoles have pole faces contoured to produce a k -value of -0.33 m^{-2} [1,2]. In order to simplify fabrication, a choice was made to construct the magnets with straight rather than curved cores. Figure 2 shows a plan view of the curved beam trajectory passing through the dipoles. To first approximation, the trajectory describes a hyperbolic cosine curve [3, 4] rather than a uniform radius curve. At the magnet entrance, center, and exit, the trajectory is offset from the nominal magnet centerline by 16.6 mm. The good field region (GFR) was specified by adding 32 mm to the trajectory offset for a total span of almost 98 mm. The wide GRF specification results in the wide magnet cross-section shown in Fig. 1.

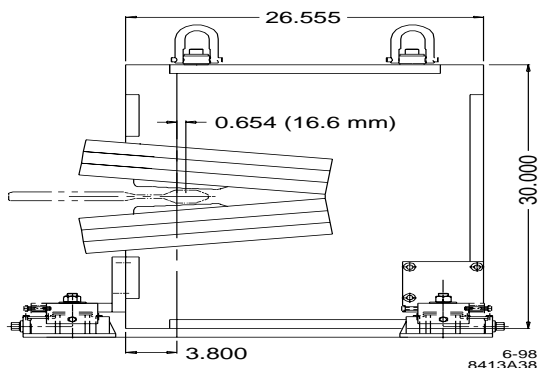

Figure 1: Cross section of a SPEAR 3 gradient dipole magnet.

*work supported in part by Department of Energy Contract DE- AC03-76SF00515 and Office of Basic Energy Sciences, Division of Chemical Sciences.

[†]E-mail: corbett@ssrl.slac.stanford.edu

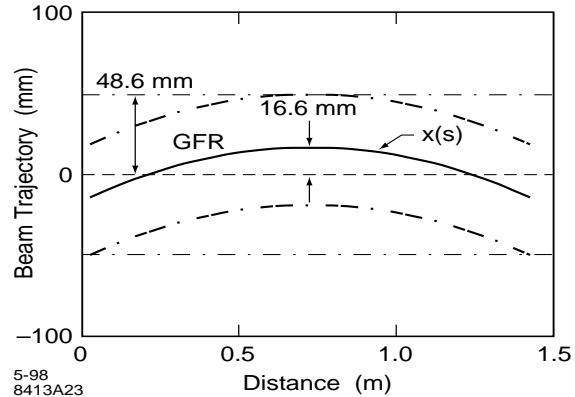

Figure 2: Beam trajectory through a SPEAR 3 dipole.

The error multipoles sampled by the off-axis beam are ‘spilldown’ terms from higher to lower multipoles. Simple examples of spilldown are the dipole kick received by a beam passing off-axis through a quadrupole, or the quadrupole and dipole field components seen by a beam passing off-axis through a sextupole. In a straight dipole magnet with multipole field content, the spilldown terms come from the lateral displacement of the beam along the curved trajectory.

In this paper, we present a matrix formalism to calculate the spilldown coefficients following the beam trajectory through the SPEAR 3 dipoles. The multipole content originates from systematic field errors caused by the finite extent of the poles. For tracking purposes the dipole magnets were sliced longitudinally, with each slice assigned appropriate multipole spilldown terms.

2 MULTIPOLE CALCULATIONS

The multipole content of the dipole magnets must be identified to evaluate lattice performance in tracking simulations. In practice, tracking codes typically specify multipole components with respect to the ideal beam trajectory. If the beam deviates from this trajectory (orbit errors, betatron oscillations) the multipole components ‘kick’ the beam resulting in tune shift, resonant excitation, etc. To be consistent, for a curved beam trajectory through a ‘straight’ dipole field the multipole spilldown fields should also be taken into account.

For SPEAR 3, we felt the $\pm 16.6 \text{ mm}$ deviation of the *design* electron beam trajectory from the straight multipole axis in the dipole magnets was sufficiently large to warrant further investigation. The high order

multipoles could spill down to components with potentially adverse effects on dynamic aperture.

To model this behavior, we ‘sliced’ the dipole magnets longitudinally and computed the net multipole terms in the center of each slice. The sliced magnets with associated multipole terms were then used for dynamic aperture simulations.

The multipole field components at any location displaced laterally by Δx from the magnet center can be expanded about the nominal center of the magnet as [5]:

$$\frac{B_n}{B} = \left(\frac{B_n}{B}\right)_{r_o} \left(\frac{z + \Delta x}{r_o}\right)^{n-1}$$

$$= \left(\frac{B_n}{B}\right)_{r_o} \left(\frac{1}{r_o}\right)^{n-1} \times \left(z^{n-1} + (n-1)z^{n-2}\Delta x + \binom{n-1}{k} z^{n-1-k} \Delta x^k + \dots \Delta x^{n-1} \right)$$

where $z = x - iy$ and $\binom{n-1}{k}$ is the binomial coefficient $\frac{(n-1)!}{k!(n-1-k)!}$.

Collecting terms with like powers of z from each straight multipole component, the net multipole spill down coefficients are computed. The computation can be expressed as a matrix equation, $\mathbf{b}_{\text{spill down}} = [\mathbf{T}]\mathbf{b}_{\text{center}}$ where the elements in the ‘spill down’ column vector $\mathbf{b}_{\text{spill down}}$ are $\left(\frac{B_n}{B}\right)_{r_o, \Delta x}$ and the elements in the center column vector are $\left(\frac{B_n}{B}\right)_{r_o}$ for $n \geq 2$. Defining $\delta = \Delta x / r_o$, the row/column elements T_{ij} in the transfer matrix $[\mathbf{T}]$ can be written as:

where $T_{ij} = k_{ij} \Delta x^{j-i}$

$$\begin{aligned} k_{ij} &= j && \text{for } i, j \geq 1 \\ k_{i1} &= 0 && \text{for } i > 1 \\ k_{ij} &= k_{(i-1)(j-1)} + k_{i(j-1)} && \text{for } i > 1 \text{ and } j \geq 1. \end{aligned}$$

The structure of the transfer matrix is quite simple. For example a maximum multipole error index of $n=6$ (maximum $i, j=5$) has the transfer matrix:

$$[\mathbf{T}] = \begin{vmatrix} 1 & 2\delta & 3\delta^2 & 4\delta^3 & 5\delta^4 & | \\ 0 & 1 & 3\delta & 6\delta^2 & 10\delta^3 & | \\ 0 & 0 & 1 & 4\delta & 10\delta^2 & | \\ 0 & 0 & 0 & 1 & 5\delta & | \\ 0 & 0 & 0 & 0 & 1 & | \end{vmatrix}$$

| Multipole | Nominal |
|-----------|-----------------------|
| n=3 | +1.0x10 ⁻⁴ |
| n=4 | -1.0x10 ⁻⁴ |
| n=5 | -5.0x10 ⁻⁵ |
| n=6 | +1.0x10 ⁻⁴ |
| n=7 | -1.0x10 ⁻⁴ |
| n=8 | +1.0x10 ⁻⁴ |
| n=9 | +1.0x10 ⁻⁴ |
| n=10 | -1.0x10 ⁻⁴ |

Table 1: Normal multipole content B_n/B in the SPEAR 3 dipoles evaluated at $r_o=30$ mm from the straight magnetic centerline.

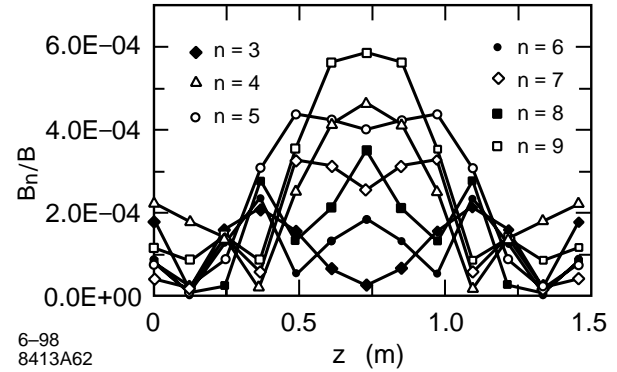

Figure 3: Normal multipole spill down terms (B_n/B) at $r_o=30$ mm as a function of longitudinal position.

The binomial coefficients are evident in the columns of $[\mathbf{T}]$. After computing the trajectory variation Δx through the magnet, the ‘local’ multipole spectrum $\mathbf{b}_{\text{spill down}}$ is calculated by multiplying the nominal multipole spectrum along the straight magnetic axis ($\mathbf{b}_{\text{center}}$) by the transfer matrix $[\mathbf{T}]$.

For the SPEAR 3 magnets the systematic multipole errors normalized to the fundamental field were computed from ANSYS. The resulting values for B_n/B are listed in Table 1 [6]. Figure 3 shows the corresponding spill down terms plotted as a function of longitudinal position. For comparison, SPEAR 3 tracking simulations are typically performed with $B_n/B = 5 \times 10^{-4}$ at $r_o=30$ mm for all systematic multipole fields throughout the full length of each dipole. The average values in Fig. 3 are considerably below 5×10^{-4} .

3 TRACKING STUDIES

The impact of spilldown on SPEAR 3 dynamic aperture was evaluated with element-by-element tracking simulations. The spilldown effect was simulated in each of the twenty eight 1.45 m dipoles. Eight additional 3/4-bend dipoles [2] have a smaller sagitta so spilldown effects were neglected. Each 1.45 m dipole magnet was sliced into 10 segments and assigned systematic multipole fields according to Table 1 and Figure 3. All magnets in the storage ring were seeded with rms main field errors, rms multipole errors, and alignment errors [7]. The lattice tracking code LEGO [8] then performed orbit correction, betatron tune fitting ($Q_x=14.19$, $Q_y=5.23$), chromaticity correction ($\xi_x=\xi_y=0$) and coupling correction prior to tracking.

To test the sensitivity of dynamic aperture to multipole content in the dipoles, the set of straight-magnet multipoles in Table 1 was uniformly scaled to higher values, spilldown calculations performed and tracking simulations carried out. In this case, the simulations showed little or no reduction of dynamic aperture for a scaling factor up to 10 times the values listed in Table 1.

The insensitivity of dynamic aperture to multipole field amplitude in the dipole magnets is likely due the low value of the horizontal betatron function throughout much of the magnets and cancellations of multipole kicks as the electron beam trajectory traverses from inside to outside and back through the dipole magnets.

Although strong skew multipole terms are not anticipated from the dipole magnets (single piece lamination) skew effects were also studied by rolling the dipole magnet cores. Since the dipole magnets contain a quadrupole field, the nominal rms roll specification is 0.5 mrad. To increase the skew multipole terms, the rms roll was raised to as much as 5 mrad with the factor of 10 multipole scaling applied. Again, negligible effect was observed on the dynamic aperture. For these simulations, the vertical dipole kicks produced by rotating the vertical dipole field were partially canceled by applying a horizontal 'multipole' field $A_1 = \sin(\theta)/\rho$. The kick cancellation was necessary to produce stable (uncorrected) closed orbits in the vertical plane.

4 SUMMARY

This paper provides a simple yet elegant formalism to calculate the multipole spilldown terms for a curved beam trajectory through a straight dipole magnet. The method was applied to the SPEAR 3 dipoles to simulate the dynamical effects of lateral beam displacement. The local spilldown terms were found to exceed the 'straight' dipole values by as much as a factor of 5-10 at maximum beam displacement. The *average* values of B_n/B , however, are below the longitudinally constant field values $B_n/B =$

5×10^{-4} | $r_0=30$ mm used for most SPEAR 3 tracking studies [2,7].

Using a 'sliced' dipole model, multipole spilldown was found to have only a small effect on dynamic aperture even after the multipole strengths were scaled up by a factor of 10. Studies of skew multipole terms introduced by rolling the dipole magnet also showed little or no effect on dynamic aperture. Based on these studies, the straight magnet core design for the gradient dipoles appears to yield acceptable performance.

5 ACKNOWLEDGMENTS

The authors would like to thank Max Cornacchia and Klaus Halbach and Yunhai Cai for stimulating conversations and important theoretical contributions in the course of this study.

6 REFERENCES

- [1] J. Tanabe, 'SPEAR 3 Gradient Magnets', SSRL Internal Memo, Sept. 19, 1997.
- [2] 'SPEAR 3 Conceptual Design Report', Stanford Synchrotron Radiation Laboratory, in press.
- [3] H. Wiedemann, Particle Accelerator Physics, Springer-Verlag, Berlin Heidelberg, 1993.
- [4] D. Dell'Orco, 'Beam Orbit through the SPEAR 3 Gradient Dipoles', SSRL Internal Memo, January 20, 1999.
- [5] J. Tanabe, 'SPEAR 3 Gradient Magnets - Off-Axis Multipoles', SSRL Internal Memo, April 1, 1998.
- [6] J. Tanabe, 'SPEAR 3 Gradient Magnets - Evaluation of Poisson Data', SSRL Internal Memo, March 28, 1998.
- [7] Y. Nosochkov, et al, 'Dynamic Aperture Studies for SPEAR 3', these proceedings.
- [8] Y. Cai, et al, 'LEGO: A Modular Accelerator Design Code', 1997 PAC, Vancouver, British Columbia, Canada, May 12-16, 1997.