

ESS CONTROLS STRATEGY AND THE CONTROL BOX CONCEPT*

T. Satogata[#], Jefferson Lab, Newport News, Virginia, U.S.A.
 I. Verstovsek, K. Zagar, and J. Bobnar, Cosylab, Ljubljana, Slovenia
 S. Peggs and C.G. Trahern, ESS, Lund, Sweden

Abstract

The European Spallation Source (ESS) will be constructed by a number of geographically dispersed partner institutions in an international collaboration [1]. This increases organizational risk, as control system integration will be performed by a large number of quasi-independent teams. Significant effort will be put into standardization of hardware, software, and development procedures early in the project. The ESS will use EPICS, and will build on the positive distributed development experiences of SNS [2] and ITER [3-5]. The basic unit of standardization is called the Control Box. This consists of one or more input/output controller (IOC) computers, zero or more I/O modules, PLC subsystems, and intelligent special-purpose controllers, and includes software and integrated development environment support. We present the challenges faced by Control Box plans for ESS, and expected benefits.

INTRODUCTION

Lund was chosen as the ESS site in May 2009. The Design Update phase (Jan 2011 to Dec 2012) will be completed with delivery of a Technical Design Report (TDR). ESS will deliver proton beam through a ~420m superconducting linac, and is expected to begin delivering beam to users in 2019. ESS will eventually deliver a nominal average proton current of ~50 mA at ~2.5 GeV in ~2 ms long pulses with a repetition rate of ~20 Hz to a single neutron target station, for a nominal average beam power of 5 MW.

There are several base assumptions for ESS control system planning:

- ESS will use the EPICS control system.
- ESS will use the Linux operating system in the controls service tier.
- ESS will use the Oracle relational database system as a project-wide RDBMS.

After approval of the CDR in late 2012, the ESS project will proceed with R&D and construction, installation, and commissioning. ESS partner institutions doing development and R&D work over many geographical locations will be supplied with Control Boxes and given tools to enforce standards for common data management issues such as naming conventions, source code control, and controls development environment.

THE CONTROL BOX CONCEPT

The SNS project faced similar distributed controls and integration development challenges [2]. Several later projects, particularly ESS and ITER, are following the SNS distributed collaborative accelerator construction model and also require early broad controls coordination.

The Control Box concept is similar to the Plant System Host (PSH) concept used in ITER controls development [3]. In ITER terminology, the Control Box philosophy is realized with the concepts PSH, mini-CODAC [4], and Plant System I&C (instrumentation and control). The main purposes of the Control Box are to:

- allow independent and yet standardized subsystem controls development,
- enforce consistency between subsystems (possibly including target and experimental stations),
- facilitate testing of new components (e.g. EPICS drivers),
- allow centralized acceptance testing of subsystems through the control system,
- validate technology decisions,
- reduce risks early to lower projection integration uncertainty and effort,
- force early documentation of standards,
- and minimize throw-away hardware and software development.

An example structure of an ESS Control Box is shown in Fig. 1. The ITER Plant System I&C document [5] discusses the different available approaches to Control Box design.

* Authored by Jefferson Science Associates, LLC under U.S. DOE Contract No. DE-AC05-06OR23177.

[#]satogata@jlab.org

CONTROL BOX COMPONENTS

A generic ESS Control Box will consist of several software and hardware components:

- One or more EPICS input/output controller (IOC) computers.
- Zero or more I/O modules (analog-digital converters and digitizers, digital-analog converters, serial interfaces, etc.) attached to the IOC computer’s hardware bus.
- A real-time or non-real-time operating system, depending on the requirements on IOC processing.
- A subset of the ESS EPICS real-time database to maintain values of all process variables under responsibility of the IOC.
- EPICS device support, which implements drivers for communication with equipment.
- EPICS Channel Access, which allows the process variables on the Control Box to be accessed from other computers in the network, and can retrieve values of process

variables from other IOCs.

- PLC subsystems for slow industrial controls (e.g., water cooling; HVAC, etc), connected to the IOC with one of several standard communication mechanisms, such as PROFINET or Modbus TCP/IP.
- Intelligent special-purpose controllers (e.g. LLRF controllers).

A standard set of supported PLCs will be established during the ESS Design Update, similar to SNS and ITER. Intelligent controller development will occur as part of R&D and construction, and controller drivers will be shared with the EPICS collaboration.

The ESS Control Box distribution will package an EPICS distribution, Linux distribution, middleware, development environment, and documentation. This approach is similar to existing approaches by the NSLS-II and ITER projects. We are investigating IRMIS for project-wide PV management. Application-

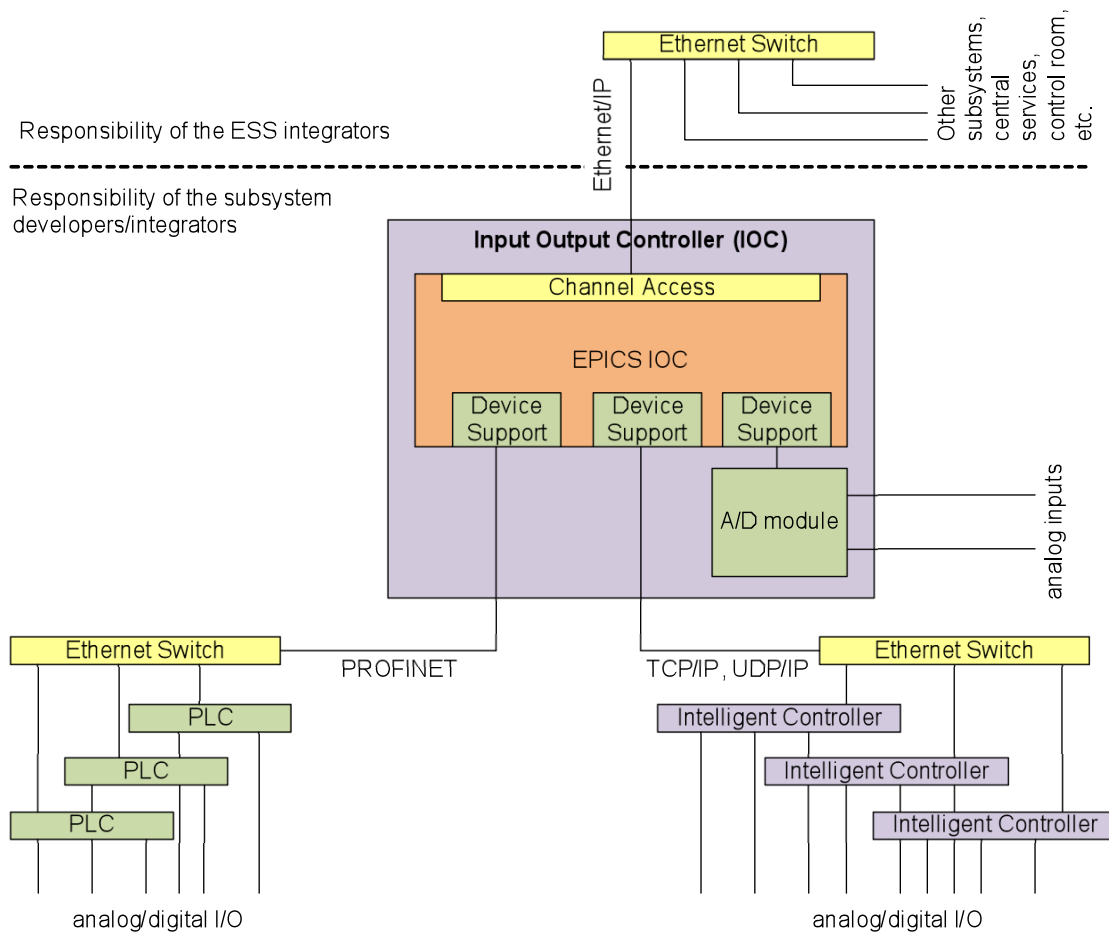

Figure 1: A schematic of Control Box components for ESS.

level development will use Control System Studio (CSS) [6] and XAL [7], and ESS and CosyLab are participating in a growing XAL collaboration [8]. A prototype of this Control Box package is a planned deliverable at the end of the ESS Design Update.

DATA MANAGEMENT

Data management among disparate R&D projects becomes another challenge that has control integration implications. In this area, one strength of EPICS (ease of adding and removing control points and IOCs) can also produce integration, maintenance, and diagnosis problems.

Central inventories will help manage this data and provide an infrastructure for consistency between distributed development and centralized machine design efforts. With limited resources, the ESS will focus on leveraging existing solutions such as the EPICS Channel Archiver [9] for historical values of process variables, CERN EDMS [10] for technical documentation and installation management, and IRMIS [11] for EPICS control inventory.

Project data integration during the design phase will be largely driven by the machine model in top-down design approach. A schematic of this approach is shown in Fig. 2. This also provides an infrastructure for naturally coordinating machine design through control system details such as lattice and control point names, such as in XAL.

DEVELOPMENT

Defining standards before R&D development may lower integration risk, but it raises technical risk. Controls development projections are quite uncertain nearly a decade from first delivered beam. Control Box development and support must therefore iterate through the R&D phase to react to changes in the technical landscape, incorporate new developments in EPICS, and distribute best use cases through the project. We plan to develop the ESS Control Box in annual cycles.

Early implementation costs are another challenge. The Controls Box concept requires enough maturity and management support at the

outset that ESS development partners “buy in”, and do not hide fragmentation beneath a layer of conformity. Early definition of naming standards is a priority of development, and agreement to adherence to these standards will be a requirement for ESS partners.

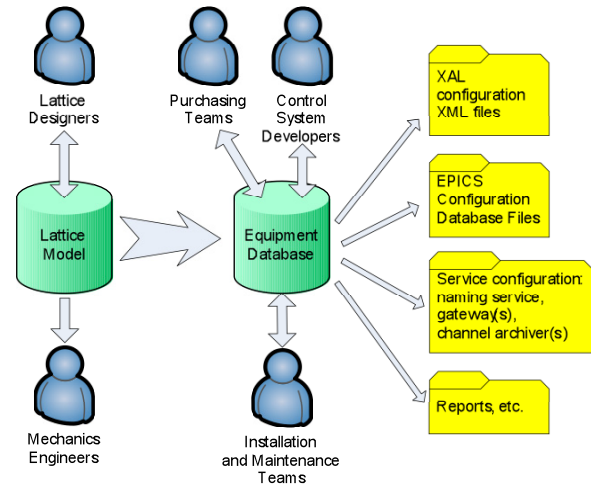

Figure 2: Flow of model data for top-down ESS control system design.

REFERENCES

- [1] M. Eshraqi et al., “Conceptual Design of the ESS Linac”, IPAC’10, Kyoto, Japan, June 2010, pp. 804-6.
- [2] D.P. Gurd, “Management of a Large Distributed Control System Project”, ICALEPCS’01, San Jose, California, Nov 2001, pp. 58-63.
- [3] A. Wallander et al., “ITER Instrumentation and Control – Status and Plans”, Fusion Engineering and Design **85**, July 2010, pp. 529-534.
- [4] J.B. Lister et al., “The Status of the ITER CODAC Conceptual Design”, *ibid* **83**, April 2008, pp. 164-9.
- [5] A. Wallander, L. Scibile, Plant System I&C Architecture, <http://tinyurl.com/2g4rhuy>
- [6] <http://ics-web.sns.ornl.gov/css/>
- [7] <http://www.ornl.gov/~t6p/Main/XAL.html>
- [8] J. Bobnar et al., “Applicability of XAL for ESS”, these proceedings.
- [9] <http://ics-web.sns.ornl.gov/kasemir/archiver/>
- [10] <http://edms.cern.ch/>
- [11] <http://irmis.sourceforge.net/>