

# AUTOMATION OF THE MAGNETIC FIELD MEASUREMENTS OF THE AIR COILS BY MEANS OF THE MOVING WIRE SYSTEM

M. Yakopov<sup>†</sup>, S. Abeghyan, S. Karabekyan, J. Pflueger, European XFEL Hamburg, Germany  
Z. Zhao USTC/NSRL, Hefei, Anhui, People's Republic of China

## Abstract

To ensure self-amplified spontaneous emission process the undulators, of a used for this, must not deflect the electron beam from its orbit. The possible deflection of the electron beam, introduced by undulator, must be corrected by means of two air coils. These air coils which are installed from both sides of the undulator, must eliminate not only the deflection angle, but also the displacement between electron beam trajectory and the orbit. For European XFEL 182 air coils are necessary. The magnetic field of each air coil was measured, to determine a conversion coefficient used by the control system. To minimize the measurement time an automated procedure has been developed and implemented. This paper describes the measurement setup, technical implementation method and automation procedure.

## INTRODUCTION

At both ends of each undulator, used by European XFEL [1], gap dependent steering errors may occur due to unavoidable magnet imperfections. These errors lead to the errors in the 1st and the 2nd Field Integral. One of the important tasks during the commissioning of the undulators in the XFEL magnetic hutches is the exact measurement of the gap dependency of upstream and downstream kicks as a function of the gap. For the compensation of these errors an air coil corrector is foreseen on either end. The serial production of the air coils has been successfully done by an industrial supplier. There are 91 air coils with 12 mm gap and 91 air coils with 32 mm gap, due to geometry of the vacuum chamber, where they supposed to be installed. In order to precisely operate air coils, both software and hardware solution have been integrated into the undulator control system [2], which is based on the Beckhoff automation technology. The software requires the conversion coefficients between currents and steering strengths of the different coils. For precise determination of the conversion coefficients of all air coils an automated test stand has been built based on the moving wire (MW) technique [3]. The conversion coefficients obtained in this way have been implemented in the undulator control system. In addition the distribution of the first field integral across the air coil gap, a crosstalk of the vertical ( $B_y$ ) component of produced magnetic field to the horizontal ( $B_z$ ) component and vice versa have been measured. These measurements were a part of the commissioning procedure of the air coils.

## AUTOMATED MEASUREMENT SETUP

### Description of the Setup

The centerpiece of the measurement setup is the MW measurement system [4]. It is an automated system aimed to the measurements. A LabVIEW program is used to control the measurements, perform the data analysis and manage the data storage. The MW system is operated by a XPS – Newport controller which communicates with the control PC through the TCP/IP network protocol. The measurement setup also includes a water cooling system for the air coils. The functional diagram of the test setup is shown in Fig. 1. A hardware controller has been created for switching ON and OFF the power supplies of the air coils. The controller was operated by XPS via a GPIO interface. The current setting of the two power supplies has been adjusted manually to 1 A and controlled by Keithley multimeters with  $\pm 5 \mu\text{A}$  accuracy for both  $B_y$  and  $B_z$  magnetic field components.

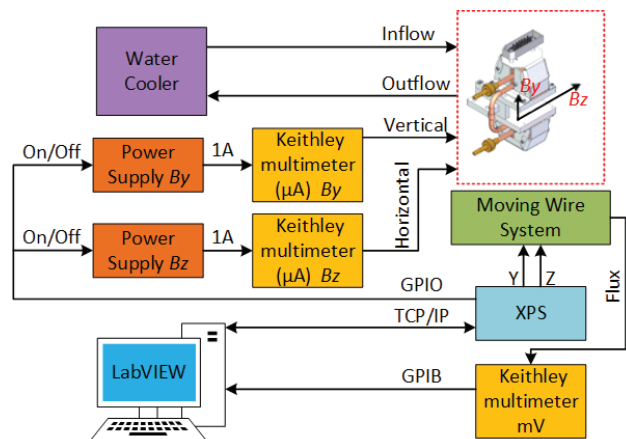

Figure 1: Functional diagram of the magnetic field measurement test setup of the air coils.

### Functionality of the setup

The distribution of the first field integral of  $B_y$  and  $B_z$  components across the gap of the air coils have been measured using the developed Labview software. Before starting the measurements, the air coils have been installed on a specially designed holder, and the front edge of the wire has been positioned at the geometrical middle point of the air coil gap, in X and Y directions. Figure 2 shows an air coil installed on the MW bench ready for measurements.

<sup>†</sup> mikhail.yakopov@xfel.eu

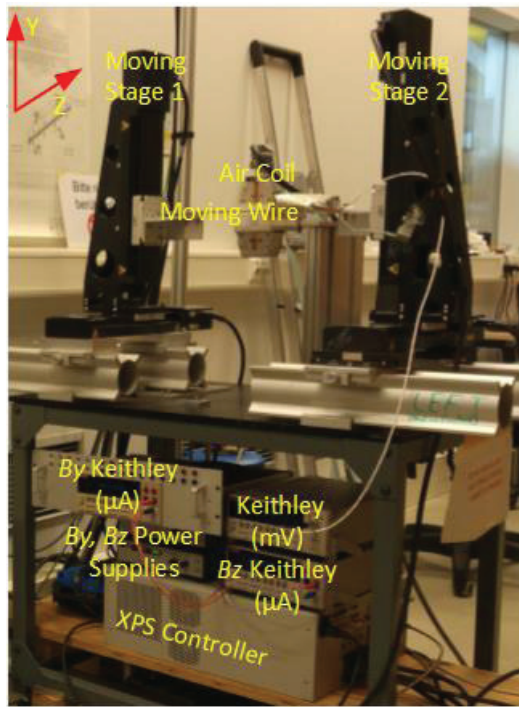

Figure 2: View of the moving wire setup used for the air coil measurements.

Once proper alignment of the moving wire with respect to the gap of the air coil is done, the automatic measurement software may be started.

### MEASUREMENT PROCEDURES

There is a slightly different procedure implemented to measure the distributions of the first field integrals for air coils with 32 mm and a 12 mm gap. The difference is in the alignment procedure of the MW, in the vertical direction. In case of 32mm air coil this alignment is done automatically by means of so called *By* scan. To start the measurements, the proper air coil needs to be selected in the GUI of the control program. By clicking the start button all settings will become active and the measurement process will run automatically with the following steps:

1. Powering of the *By* coil;
2. Measuring the first field integrals with 1mm steps in the range of -10 mm to 10 mm along Y direction from the estimated middle point;
3. Un-powering the *By* coil, and eventually moving the wire into a new initial position.

The *By* field integral, as a function of Y direction, is shown in the left part of Fig. 3. The minimum indicates the true magnetic centre of the air coil. This position is taken as a new initial coordinate. The second and eventually next iteration of measurements is done for verification purpose. The final initial position of the magnetic centre is shown in the right part of Fig. 3.

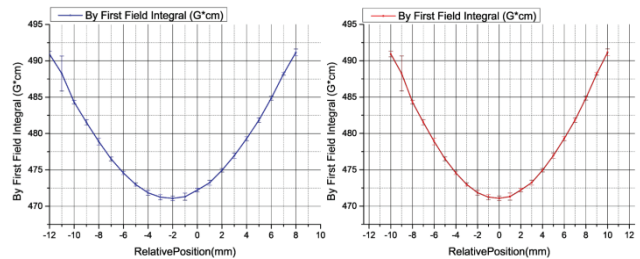

Figure 3: *By* scan of 32 mm air coil. Left -before and right - after the automatic alignment

Once this is done, the next steps will start automatically. This step actually uses the same principle that is implemented for the measurements of the *Bz* component. This step is done for both, 12 mm and 32 mm air coil measurements. In this step only *Bz* air coil is powered. The travel range is from -20 mm to 20 mm along the Z direction. The deviation between the maximum measured value and the initial position of the wire needs to be found. Afterwards the MW is aligned with respect to the centre of the air coil in the Y and Z direction. The following steps characterize the coil properties, especially the cross-talk between the coils. The third step includes the measurement of the first field integral of the *By* and *Bz* components in the median plane while both coils are powered. Travel range is from Z = -20 mm to 20 mm with 1 mm steps. The fourth step repeats the previous measurements without powering the *Bz* power supply, to measure only the value of *By* air coil without the contribution of the *Bz* air coil. The fifth step repeats the previous one by measuring only the *Bz* air coil without powering the *By* air coil. The sixth step repeats the same measurements with unpowered air coils. This measurement gives the *By* and *Bz* values of the ambient magnetic field, which need to be subtracted to get the real values produced by air coils. As it was already mentioned, all measurements have been done with the powering of the air coils with 1 A current. Once the measurements are done the final table and plots will be generated automatically. All obtained data, shown as a function of Z direction in the median plane. Table 1 gives an overview over the measured data.

Table 1: Overview over the Measured Data

Signals (G*cm)	Description
BY_BY1_BZ1	<i>By</i> with powered both <i>By</i> and <i>Bz</i> coils
BZ_BY1_BZ1	<i>Bz</i> with powered both <i>By</i> and <i>Bz</i> coils
BY_BY1_BZ0	<i>By</i> with powered <i>By</i> coil only
BZ_BY0_BZ1	<i>Bz</i> with powered <i>By</i> coil only
BY_BY0_BZ0	Y - vertical ambient magnetic field
BZ_BY0_BZ0	Z - horizontal ambient magnetic field

### ANALYSIS OF DATA

To visualize and analyse the data another LabVIEW program was developed. The program generates the plots and visualizes them. The user interface of the program

allows to display any combination of the measured data. In the Fig. 4 all 8 measurement results are selected.

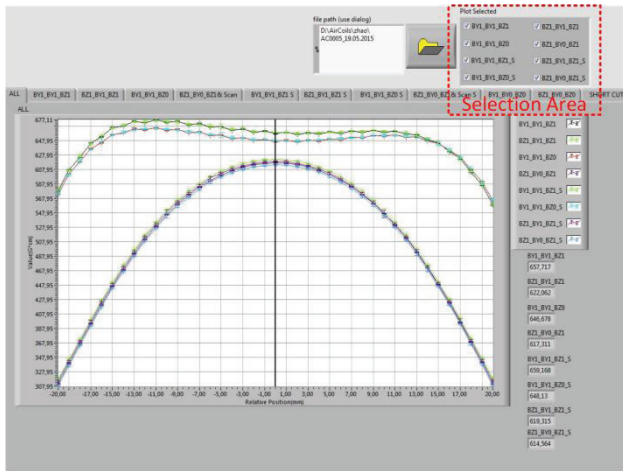

Figure 4: Graphical user interface of the program for the data analyses.

### MEASUREMENT RESULTS

The main result for the undulator control system is the value of the first field integral of both  $B_y$  and  $B_z$  components, measured in the centre of the gap of the air coil. The ambient magnetic field must be subtracted. An example of the measured  $B_y$  component for 12 mm gap air coils is shown in Fig. 5.

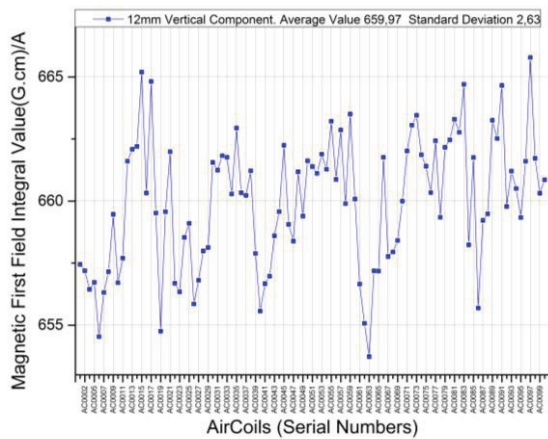

Figure 5: First field integral in Y direction at Y, Z=0 of entire amount of air coils with 12 mm gap. The ambient magnetic field is subtracted.

In the same way the  $B_z$  component of the air coils with 12 mm gap as well as both components of the air coils with 32 mm gap have been analysed.

### IMPLEMENTATION OF THE CONVERSION COEFFICIENTS

The conversion coefficients, which are necessary to produce magnetic field value according to the set value, have been implemented in the undulator control system.

The air coils control algorithm uses the following equation:

$$\text{AppliedValue[A]} = |\text{SetValue[Tmm]}| * 32768 * B \quad (1),$$

where B is the conversion coefficient, which converts the applied current to the field integral for a specific type of the air coil. The following values have been used for calculating the corresponding transformation coefficients for the undulator control system (see Table 2):

Table 2: Average Values of Final Coefficients for 12 mm and 32 mm Air Coils

Coefficients (Tmm/A)	Standard Deviation
$B_{yAve12}=0,65997$	$0,00263$
$B_{zAve12}=0,61855$	$0,00227$
$B_{yAve32}=0,47724$	$0,00135$
$B_{zAve32}=0,40862$	$0,00146$

### CONCLUSIONS

The MW setup allowed to make relatively fast commissioning of the complete set of the air coils with the accuracy better than 1 G cm (0.001 T mm) [4]. A standard deviation < 0.4% of all measurements has been achieved. An average  $B_{Ave}$  coefficients were considered sufficient to use during the commissioning of the undulator control system. These coefficients have been implemented into the undulator control system. Nevertheless, all measured data are available for each air coil, and could be used in case of any specific requirement.

### REFERENCES

- [1] Y. Li, B. Faatz, J. Pflueger, "Undulator system tolerance analysis for the European x-ray free-electron laser", *Physical Review Special Topics – Accelerator and Beams* 11, 100701, 2008.
- [2] M.Yakopov, J. Pflüger, "Connection of air coils to the XFEL Control System", WP71\_2013\_11.
- [3] J. Pflüger, "Moving Wire Measurements", WP71/2013/05.
- [4] F. Wolff-Fabris, M. Vichweger, Y. Li, J. Pflüger "High accuracy measurements of magnetic field integrals for the european XFEL undulator systems" *Nuclear Instruments and Methods in Physics Research Section A: Accelerators, Spectrometers, Detectors and Associated Equipment*, Volume 833, 11 October 2016, p. 54.