

RELUS-5 ELECTRON LINAC START-UP

D.Churanov, F.Fadin, A.Krasnov, M.Urbant, A.Zavadtsev, D.Zavadtsev,
 Nano Invest, Moscow, Russia, www.relus.ru
 N.Sobenin, MEPHI, Moscow, Russia

Abstract

The compact electron linac RELUS-5 was developed for radiation investigation of material modification.

The experience of the standing wave electron accelerator building starting since first in the USSR standing wave electron linac RELUS-1 in 1978 [1] were used.

Electron energy range is from 3 to 5 MeV. Pulse length is from 3 to 6 μ sec. Average power of accelerated beam is up to 1 kW.

The main task of submitted work is to build simple and cheap applied electron linac and to show how to do it.

INJECTOR

Three-electrode 32-40 kV 1.5 A electron gun is used as an electron injector. Injection voltage is.

Calculated shape of the injector as well as equipotential lines (pink) trajectories of electrons (green) are shown in Figure 1.

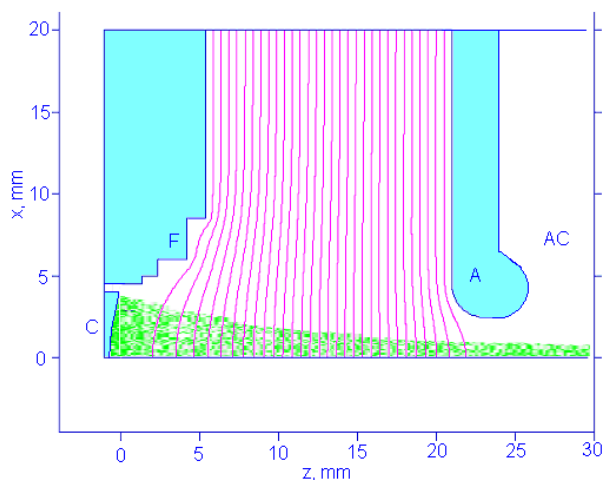

Figure 1: Calculated shape of the injector. C is the cathode, F is the focusing electrode, A is the anode, which is the wall of first accelerating cell AC of the accelerating section. Z is the accelerating section axis.

ACCELERATING SYSTEM

Accelerating system of RELUS-5 includes one section of S-band standing wave on-axis coupled biperiodic structure [2]. The section includes 11 Ω -shaped accelerating cells and 10 coupling cells. Two first accelerating cells are bunching cells with decreased phase velocity. Rest 9 accelerating cells have constant relative phase velocity, equalled to 1. So total length of the accelerating section is 0.5 m.

Aperture diameter of the section is 5 mm.

Optimal accelerating gap to period ratio is 0.6 for maximum shunt impedance in the biperiodic structure. Unfortunately this ratio was chosen equalled to 0.8. This value leads to small reduction of the shunt impedance to 73 MOhm/m and very significant increasing of electric strength of the accelerating structure [3]. Calculated distribution of electric field E in the accelerating structure model as well as distribution of accelerated electric field Ea along structure axis z are shown in Figure 2.

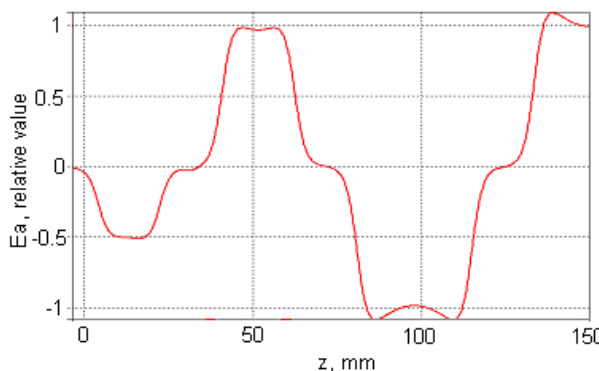
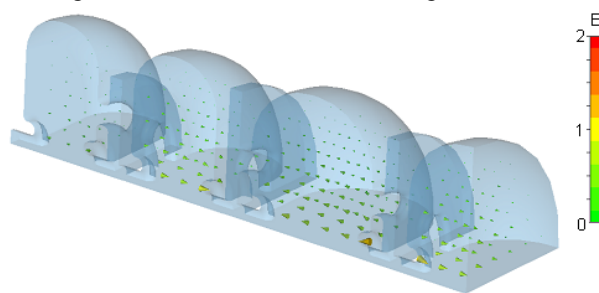

Figure 2: Distribution of electric field in accelerating structure.

The focusing of the electrons is provided with RF electromagnetic fields inside the accelerating structure. So no external focusing is used.

Calculated energy spectrum in accelerated electron beam is show in Figure 3.

RF POWER SUPPLY

RF power supply system includes magnetron (2.5 MW peak and 4.5 kW average power), ferrite Y-circulator, waveguide load, waveguide ceramic window, vacuum unit connected to ion pump, 90 degree waveguide bend and phase-shifter.

The magnetron operates in free-running mode with following feed-back loop: forward wave from magnetron through circulator (from 1-st to 2-nd port), window, vacuum unit and bend to accelerating section and then reflected wave from accelerating section though bend, vacuum unit, window, circulator (from 2-nd to 3-rd port),

phase-shifter (with reflector) and circulator (from 3-rd to 1-st port) to magnetron [4].

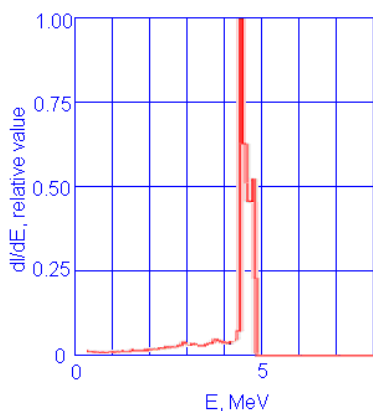

Figure 3: Calculated energy spectrum in accelerated electron beam.

The phase-shifter is connected between third port of the circulator and the load. It includes continuous regulated phase-shifter with movable matched Teflon plate, pin-reflector located near to the flange connected to the load and the antenna for monitoring of power reflected from the accelerating section. Full phase range of the continuous regulated phase-shifter is 40 degree. There are 8 locations of the pin-reflector in the phase-shifter with 10 mm period. So the phase shift in the feed-back loop for two nearest reflector locations is equal to 45 degree, and total continuous 360 degree phase regulation in the feed-back loop is achieved.

RF power supply system is filled with SF6 at 1.5 bar abs pressure from the magnetron to the window and with high vacuum from the window to the accelerating section.

MODULATOR

The modulator is needed to feed the magnetron and the injector by pulsed high voltage and by filament power.

Solid-state modulator is used in RELUS-5 linac [5]. It includes switch mode capacitor charger, capacitor, IGBT switch, pulse transformer, filament board, bias power supply, oil tank and provides:

- 50 kV, 100 A, 0-6 μ sec, 10 kW for magnetron,
- 40 kV, 2 A, 0-6 μ sec for injector,
- 12 V, 17 A for magnetron filament,
- 12 V, 3.5 A for injector filament.

The whole modulator is assembled in oil-tank with overall dimensions 88×84×95 cm.

VACUUM SYSTEM

Vacuum system provides high vacuum in the accelerating section, in the injector and in the waveguide. Oil-free vacuum system is used in the linac. It includes 80 l/min dry scroll pump to get oil-free forevacuum of 10^{-1} mbar, 70 l/sec turbo-molecular pump to get 10^{-6} mbar and 150 l/sec ion pump for final pumping to 10^{-8} mbar.

CONTROL SYSTEM

Control system includes control module, commercial PLC with I/O blocks, control terminal (desk top computer) and digital oscilloscope.

Control module was developed specially for RELUS-5 for control of the modulator, namely peak magnetron voltage (i.e. peak magnetron power and accelerated electron energy), pulse width and pulse repetition rate. The control module is used for synchronization of triggering of all IGBTs through fiber-optic lines. The control module is built on base of programmable chip.

PLC and I/O blocks are used to send control commands to linac subsystems, to receive measured signals from linac subsystems, to communicate with the control terminal (through fiber-optic cables).

Measured pulse signals are converted into optic signals and translated to the oscilloscope through fiber-optic cables.

So the control terminal and the oscilloscope located in the control room are coupled with PLC and with pulse signal sources located in linac bunker through fiber-optic cables only to decrease electromagnetic noise due to power induction.

ENGINEERING DESIGN AND EQUIPMENT LAYOUT

Linac RELUS-5 was designed by following way. The accelerating section with the injector, vacuum filled waveguide units, vacuum system and SF6 system are assembled on one common frame.

The modulator is mounted inside its oil-tank. The magnetron, SF6 filled waveguide units and oil pump of the modulator are located on special Aluminum plate on the top of the oil-tank.

The frame and the modulator oil tank are located close to each other (Figure 4),



Figure 4: Linac assembly and the modulator.

so the electrodes of the injector as well as electrodes of the magnetron are connected to high voltage isolators of the modulator by very short wires.

The control terminal and digital oscilloscope are located in the control room.

LINAC START UP

Linac subsystems were started up in following sequence: modulator, vacuum system, water cooling, RF power supply, injector, accelerating section, SF6 system, control system.

Measured pulses of anode voltage, anode current and output RF power of the magnetron are shown in Figure 5.

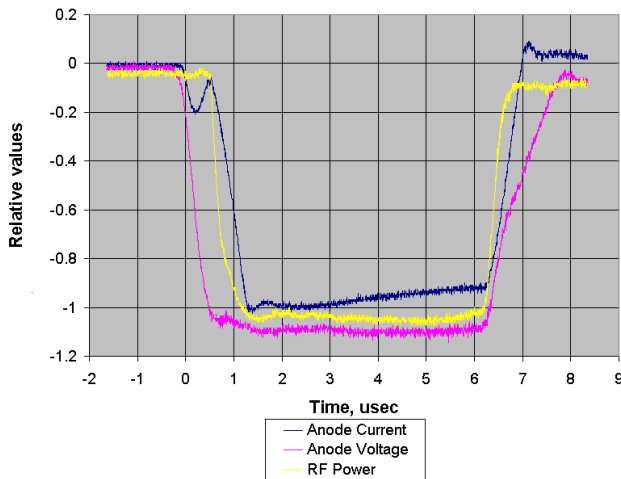

Figure 5: Anode voltage, anode current and output RF power of the magnetron.

TOMOGRAPHY X-RAY INSPECTION SYSTEMS

Nano Invest develops a series of Tomography X-ray (Roentgen) Inspection Systems (TRIS) for security and custom use. The main parameters of these systems are shown in Table 1.

Table 1: TRIS series.

TYPE	E, MeV	t, mm	a×b, cm×cm	V, m/min
TRIS - 0140-060	0.14	28	60×60	1-2
TRIS - 0140-100	0.14	28	100×100	1-2
TRIS - 0300-150	0.3	80	150×150	2-3
TRIS - 0300-180	0.3	80	180×180	2-3
TRIS - 3000-200	3	210	200×200	2-4
TRIS - 6000-250	6	340	250×250	2-4
TRIS - 9000-250	9	410	250×250	2-4
TRIS - 9000-400	9	410	250×400	2-4

E is electron energy, t is penetration in steel, a×b is window size for inspected object, V is inspection speed.

Project of TRIS - 6000-250 is shown in Figure 6.

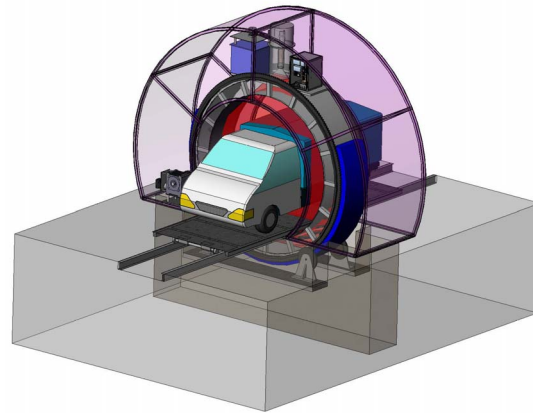

Figure 6: TRIS - 6000-250.

Cross-section of TRIS - 6000-250 shows scanning scheme in Figure 7. Multi-spiral tomography is used to get 3D image of inspected object.

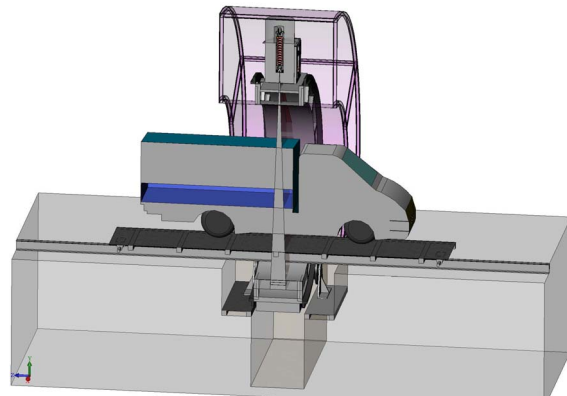

Figure 7: Cross-section of TRIS - 6000-250.

Linac RELUS-5 is a prototype of X-ray source for TRIS series with E=3-9 MeV.

REFERENCES

- [1] V.F.Vikylov, A.A.Zavadtsev, B.V.Zverev, V.E.Kaluzhny, V.I.Kaminsky, N.N.Nechaev, V.V.Rusin, N.P.Sobenin, V.V.Stepnov. A Compact Standing Wave Electron Linac with RF Drive System Using 3 dB Hybrid Junction. - IEEE Trans. Nucl. Sci., Vol. NS-26, №3, 1979, p. 4292-4293.
- [2] A.A.Zavadtsev, Yu.D.Petrov, N.P.Sobenin. Standing Wave Electron LINAC Accelerating Structure for Technology Purposes. - Fourth European Accelerator Conference. Vol.3, London, 1994, pp.2173-2175.
- [3] A.A. Zavadtsev. Biperiodic U-structures for Particle Accelerators. - Fourth European Accelerator Conference. Vol.3, London, 1994, pp.2176-2178.
- [4] A.A. Zavadtsev, V.I.Kaminsky, O.S.Milovanov. Experimental Investigation of Three-Section Standing Wave Electron Linac. Issues of Atomic Science and Technique. Series: Technique of Physical Experiment. Vol. 1(3), KPTI, Kharkov, 1979, p. 68-70.
- [5] D.Churanov, A.Krasnov, M.Urbant, A.Zavadtsev, D.Zavadtsev Solid-State Modulator for Linear Accelerators. RUPAC-2008.