

SOLID STATE MODULATOR FOR LINEAR ACCELERATORS

D.Churanov, A.Krasnov, M.Urbant, A.Zavadtsev, D.Zavadtsev,
Nano Invest, Moscow, www.relus.ru

Abstract

Compact solid state modulator is developed, assembled and tested. The modulator is designed for use in compact electron linac RELUS-5 to feed pulse mode magnetron and electron gun.

Main parameters of the modulator are: peak voltage 50 kV, peak current 100 A, pulse length 0-6 usec, rise and fall time 0.5 usec, output power up to 10 kW.

The whole modulator is located inside the oil tank with overall dimensions 88×84×95 cm.

Special circuit allows to correct the droop of the pulse and to vary the pulse length in wide range.

Modular type design allows to use it as a base for the building of another modulators with higher peak voltage up to 150-300 kV as well as with higher peak current up to 300 A.

INTRODUCTION

Solid state modulator was built for high voltage pulse power supply of the magnetron feeding accelerating cavity as well as of electron injector of the compact electron standing wave linear accelerator RELUS-5 [1].

Main parameters of RELUS-5 are

- electron energy 3...5 MeV;
- average power of the electron beam 1 kW;
- electron beam pulse length 3...5 usec.

The magnetron parameters are

- frequency 2797 MHz
- peak power 2.5 MW
- average power 4.5 kW
- max pulse length 6 usec
- rise/fall time is 0.5 usec
- anode voltage 45...55 kV
- peak anode current 100 A max
- filament voltage 12 V
- filament current 18 A.

The injector parameters are

- voltage 40...50 kV
- max injected current 1.5 A
- filament voltage 12 V
- filament current 3 A.

MAIN SCHEME

There are several approaches to build solid state modulator: modulator with full voltage serial switch [1], modulator with serial switch and pulse transformer, Marx modulator,

The main scheme of the modulator is shown in Figure 1.

The modulator is located inside the oil tank.

Power supply voltage 380 V, 3 phases is applied to 11 power modules PM1...PM11, each of them generates pulse voltage 1 kV applied to the primary winding of the pulse transformer PT. The magnetic flux of all power modules combine in the pulse transformer to generate pulse voltage in the secondary winding of the pulse transformer up to 55 kV.

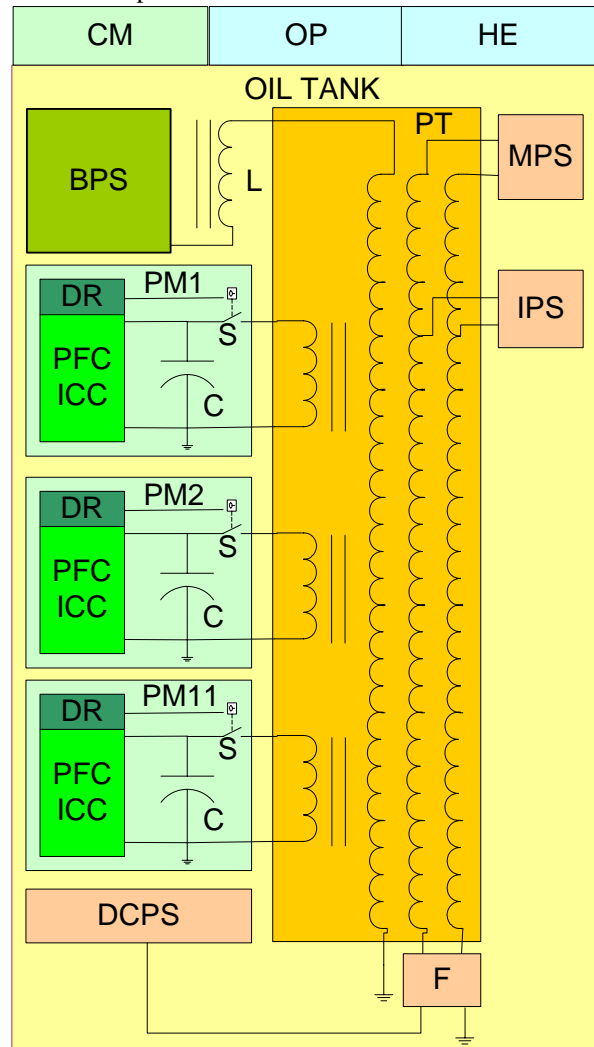

Figure1: Main scheme of the modulator

Bias power supply BPS feeds bias winding of the pulse transformer to shift operating point of the pulse transformer core.

Two high voltage blocks: magnetron power supply MPS and injector power supply IPS are used for magnetron and for injector power supply. Each of these blocks allows us to provide pulse high voltage and to adjust filament current as well as to measure pulse shape of voltage and current (separate for magnetron and

injector). Power supply of MPS and IPS is provided by DC power supply DCPS through the filter F and bifilar secondary winding of the pulse transformer PT.

Control Module CM triggers all power modules PM.

CONSTRUCTION

Power module

Main parameters of the power module PM are:

- input 380 V, 3 phase, 50...60 Hz, 1 kW
- output pulse 1.2 kV, 500 A, 3...6 μ sec
- control voltage of output voltage level 0...+5 V
- triggering through fiber-optic line 3...6 μ sec
- pulse repetition rate up to 300 Hz.

Power module includes power factor correction (PFC), inverter capacitor charger ICC, capacitor C, IGBT switch S, power diode, protection circuit, driver, and radiator. Power module PM is shown in Figure 2.

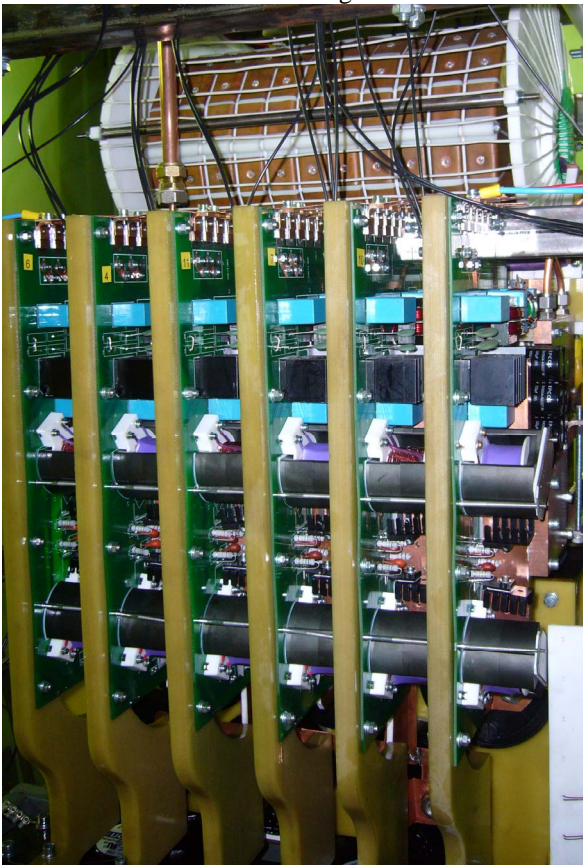

Figure 2: Power modules and pulse transformer

PFC is destined for high quality power consumption. The power module as well as the whole modulator is a resistive load with use of PFC. Output PFC voltage is 600 V DC.

Capacitor charger transforms 600 V DC to pulse voltage with amplitude up to 1.2 kV for charging of capacitor C. Charging voltage is adjusted from control system.

Charged capacitor C discharges partially through primary winding of the pulse transformer PT, when IGBT switch S is ON, creating magnetic flux in the pulse transformer core.

Driver DR opens and closes IGBT switch S with control from the control module CM through fiber-optic line.

All power modules are at zero potential.

Pulse transformer

The pulse transformer PT includes 11 cores with primary windings, bias winding, and bifilar secondary winding with taps to feed the injector.

The primary winding includes 4 turns. The shape of primary winding is simulated to minimize its inductance.

The bias winding includes 1 turns.

The secondary winding includes 20 turns.

The core is made of electro-technical steel.

Pulse transformer is shown in Figure 2.

High voltage block

There are two the same high voltage blocks MPS and IPS in the modulator connected to the magnetron and to the injector. They are used to apply high voltage, to adjust filament current as well as to measure pulse shape of high voltage and current.

The whole high voltage block is at high voltage potential (up to 55 kV). It is connected to the bifilar secondary winding with the voltage 48 V DC for power supply.

Filament current adjustment as well as measured pulse voltage and current signals is passed through fiber-optic lines.

Filter

The filter F is used to isolate pulse voltage in the secondary winding of the pulse transformer PT and the power supply DCPS. The low voltage end of the secondary winding is grounded for pulse voltage.

Bias power supply

Bias power supply BPS has been developed specially for this modulator. It provides 40 A. BPS is connected to the secondary winding of the pulse transformer PT through the choke L.

DC power supply

DC power supply DCPS is needed to feed MPS and IPS with 12V DC voltage.

Control module

The control module triggers all IGBT switches S through fiber-optic lines and drivers DR.

Cooling

The cooling scheme includes oil-water heat exchanger HE, oil pump OP, and oil distribution system, which provides oil cooling of the pulse transformer core and IGBT radiators.

Oil tank

The oil tank includes all modulator equipment, except oil pump OP and heat exchanger HE located on the tank cover as well as control module CM.

All modulator equipment is fixed at the tank cover and maybe lifted from the oil tank with the cover.

All input/output connectors of the tank are located at its cover, namely 380 V power supply connector, fiber-optic connectors, two high voltage isolators for magnetron and for injector.

Dimensions of the tank are 88×84×95 cm.

The modulator is shown in Figure 3.

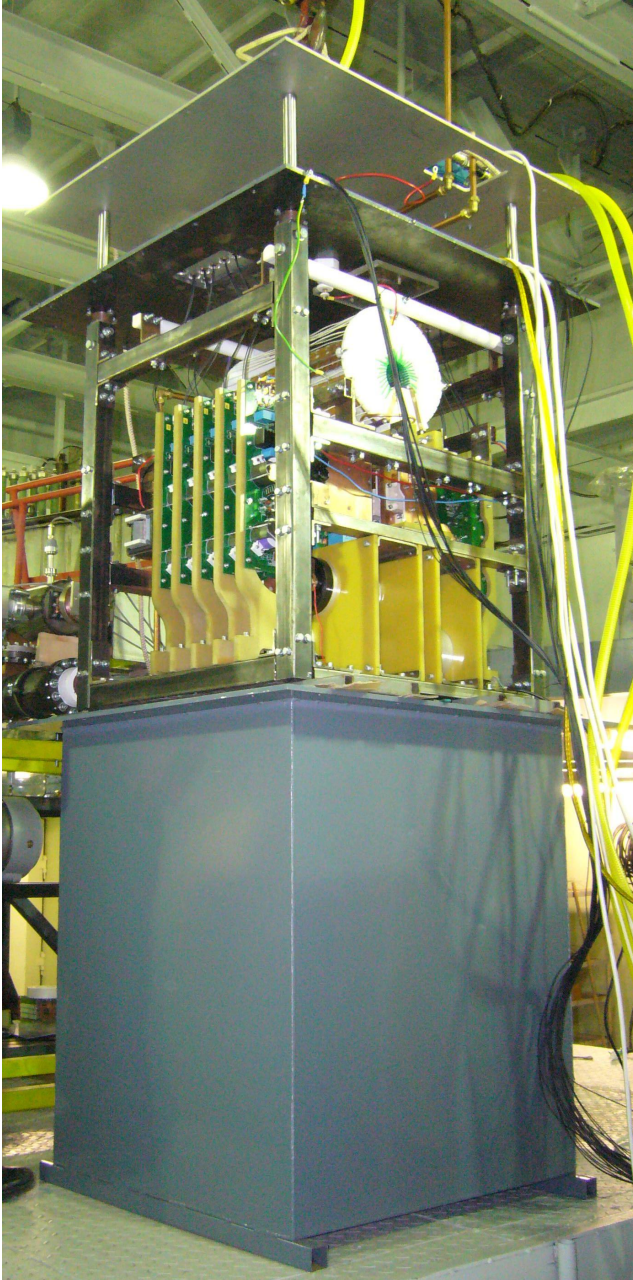

Figure 3: Modulator. (Modulator equipment and cover are lifted from the tank).

TEST RESULTS

The test of the modulator was carried out at magnetron load.

Test parameters are

- peak voltage 55 kV
- peak current 100 A
- pulse length 6 μ sec
- average output power 10 kW.

Measured pulse shape of the output voltage of the modulator loaded by the magnetron is shown in Fig.4. Rise/fall time of the modulator loaded by resistive load is 0.5 μ sec. Fall time at magnetron load is increased, because the magnetron stops RF generation at half voltage level within fall time, and magnetron impedance increases.

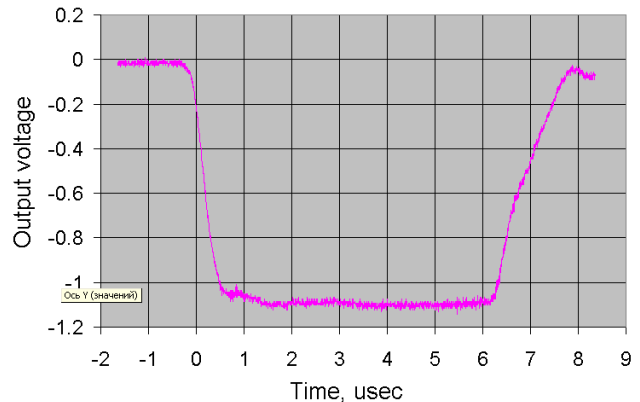

Figure4: Output voltage of the modulator

SUMMARY

Built module-type modulator for magnetron allows us to use this design to build another modulators both for magnetrons and for klystrons with wide range of output parameters:

- peak voltage up to 500 kV,
- peak current up to 500 A,
- pulse length 1...20 μ sec,
- average output power up to 50 kW.

The use of different numbers of power modules allows us to choose operating voltage. Wide range commercial IGBTs allows us to chose peak current and average power.

REFERENCES

- [1] Dr. Marcel P.J. Gaudreau, Dr. Jeffrey Casey, Timothy Hawkey, J. Michael Mulvaney, Michael A. Kempkes. Solid-State Pulsed Power Systems. 1998 Twenty Third International Power Modulator Symposium, Rancho Mirage, CA June 1998.
- [2] D.A. Zavadtsev, A.I. Fadin, A.A. Krasnov, N.P. Sobenin, and A.A. Zavadtsev. "Compact Electron Linear Accelerator RELUS-5 for Radiation Technology Application". Proceedings of EPAC 2006, Edinburgh, Scotland, p.2385-2387.