

## DESIGN OF THE NUCLOTRON BOOSTER IN THE NICA PROJECT

Andrey Butenko, Nikolay Agapov, Alexey Eliseev, Viktor Karpinsky, Hamlet Khodzhibagiyan, Alexander Kovalenko, Grigory Kuznetsov, Igor Meshkov, Vladimir Mikhaylov, Valery Monchinsky, Anatoly Sidorin, Alexander Smirnov, Grigoriy Trubnikov, Bogdan Vasilishin, JINR, Dubna, Russia

### Abstract

NICA is the new complex being constructed on the JINR aimed to provide collider experiments with ions up to uranium at energy of  $3.5 \times 3.5$  GeV/u. The NICA layout includes Electron String Ion Source, 6.2 MeV/u linac, 600 MeV/u booster synchrotron, upgraded Nuclotron and ion collider with average luminosity of  $10^{27}$  cm<sup>-2</sup> s<sup>-1</sup>. The main goals of the Booster are the following: accumulation of  $4 \cdot 10^9$  Au<sup>32+</sup> ions; acceleration of the heavy ions up to energy required for effective stripping; forming of the required beam emittance with electron cooling system. The present layout makes it possible to place the Booster having 211 m circumference and four fold symmetry lattice inside the yoke of the Synchrophasotron (shut down in 2002). The features of this booster, the requirement to the main synchrotron systems and their parameters are presented in this paper.

### INTRODUCTION

General challenge of the NICA facility is to achieve a high luminosity level of heavy ion collisions in a wide energy range starting with about 1 GeV/u. To reach this goal the NICA injection chain has to deliver a single bunch of fully stripped heavy ions (Au<sup>79+</sup>) at intensity of about  $1 \div 1.5 \cdot 10^9$  ions [1]. An effective stripping of the ions before injection into the Nuclotron requires their preliminary acceleration to an energy of a few hundreds of MeV/u. Therefore, realization of the NICA project presumes design and construction an intermediate booster synchrotron as new element of the NICA collider injection chain.

Before injection into the collider ring the Nuclotron RF system has to provide compression of the accelerated bunch. The beam parameters providing by linac-injector do not permit to realize the bunch compression with required efficiency. Thus a beam cooling at some stage of its acceleration is necessary. The Nuclotron ring has no convenient straight sections for location of the cooling system. Therefore the booster is only the place where the beam cooling can be realized. Additionally, the larger beam energy at the injection simplifies requirements to vacuum conditions in the Nuclotron beam pipe.

Correspondingly, the main functions of the intermediate heavy ion synchrotron, the Booster of the Nuclotron, are the following:

- Accumulation of  $4 \cdot 10^9$  Au<sup>32+</sup> ions that necessary to have after acceleration and stripping the beam intensity of  $1 \div 1.5 \cdot 10^9$  ions ;

- Decrease of the ion beam longitudinal emittance at the energy of 100 MeV/u approximately by application of the electron cooling;
- Acceleration of the ions up to energy of 600 MeV/u that is sufficient for stripping of the Gold ions up to the charge state of 79+;
- Simplification of the requirements to the vacuum conditions in the Nuclotron owing to higher energy and charge state of the injected ions.

### MAIN PARAMETERS OF THE BOOSTER

The huge yoke of the Synchrophasotron – the old 10 GeV proton synchrotron that was decommissioned in 2002, after the magnet winding is removed, gives a free tunnel of 4 x 2.3 m. The present layout of the Nuclotron and existing injection and extraction systems make it possible to place the Booster having 211 m circumference and four fold symmetry inside the yoke (Fig. 1).

Four large straight sections of the Booster will be used for injection from the linac, single turn extraction to transfer the beams into the Nuclotron, placing of the acceleration cavity and electron cooler. At the maximum field of dipole magnets of 1.5 T one can reach for heavy ions the energy of above 600 MeV/u that is sufficient for stripping of the ions up to the bare nucleus state (Table 1).

Table 1. Main parameters of the Booster

Ions	Au <sup>32+</sup>
Circumference, m	211 m
Fold symmetry	4
Quadrupole periodicity	24
Injection/extr. energy Au <sup>32+</sup> , MeV/u	6.2/600
Magnetic rigidity, T·m	2.2 ÷ 25.0
Dipole field, T	0.17 ÷ 1.8
Pulse repetition rate, Hz	0.25
Magnetic field ramp, T/s	1.2
Beam Injection type	Twice repeated, single turn
Beam extraction type	Single turn
Injection store duration, s	0.02
Vacuum, Torr	10 <sup>-11</sup>
Au <sup>79+</sup> beam intensity, ions per pulse	$1.5 \times 10^9$
Transition energy, GeV/u	3.98

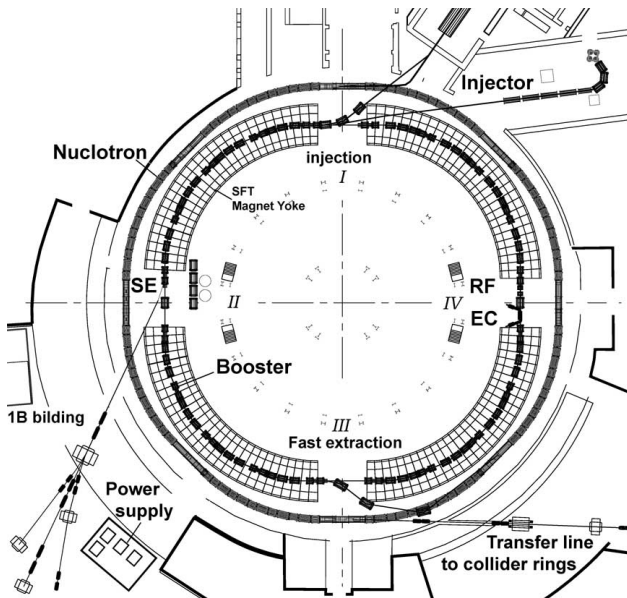

Figure 1. The Booster layout.

The Booster cycle (Fig. 2) is composed of five parts:

- the adiabatic trapping at fixed frequency (flat bottom),
- the beam acceleration at the fourth harmonics of the revolution frequency up to 100 MeV/u and debunching,
- electron cooling during 1 s in the order to form the beam emittance required for successive acceleration and extraction from the Nuclotron,
- the beam bunching at the first harmonics of the revolution frequency together with the electron cooling,
- the beam acceleration at the first harmonics of the revolution frequency up to 600 MeV/u.

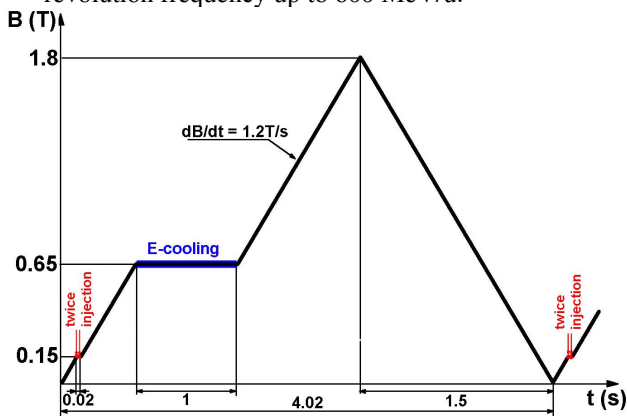

Figure 2. Booster cycle diagram, time is in seconds

The cycle duration is chosen to be approximately equal to the Nuclotron one, which is optimum for the collider feeding.

### LATTICE & BEAM DYNAMICS

The chosen lattice (Table 2 and Fig. 3) contains 4 arcs. Each arc consists of 5 regular FODO cells with dipoles and one without them. One regular cell includes focusing and defocusing quadrupoles, one sector dipole and small

drift section used for location of magnetic correctors, beam position monitors, collimators and so on. The equipment of injection, ejection and acceleration are placed in the four large straight sections. In the vicinity of the working point there are only two systematic betatron difference resonances of the fourth order:  $3Q_x - Q_y = 12$  and  $3Q_y - Q_x = 12$ . Both are quite distant from the chosen tunes of  $Q_{x,y} \approx 5.8$ .

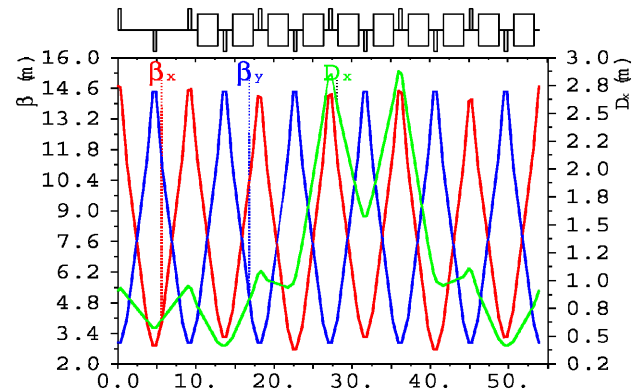

Figure 3. Betatron and dispersion functions for one SP.

Table 2. Lattice parameters of the Booster

Fold symmetry	4
Number of the FODO lattice cells per arc	6
Length of large straight sections, m	4.1x2
Length of small straight sections, m	0.65
Betatron tunes	5.8/5.85
Amplitude of $\beta$ -functions, m	14.6
Maximum dispersion function, m	2.9
Momentum compaction factor	0.038
Chromaticity	-7.0
Horizontal acceptance, $\pi \cdot \text{mm} \cdot \text{mrad}$	400
Vertical acceptance, $\pi \cdot \text{mm} \cdot \text{mrad}$	70

The twice repeated single turn injection has duration of 7  $\mu\text{s}$  per pulse with a betatron stacking in the horizontal plane. The injection scheme includes three bump magnets BM 1  $\div$  3 and one septum magnet SM (Fig. 4.). The bump magnets form the necessary local distortion of the closed orbit that decreases by two steps during injection time. The time interval between injection pulses is of 0.1 s.

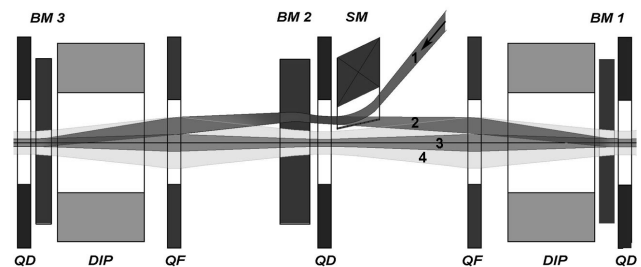

Figure 4. Injection system layout and beam orbits and envelopes: 1 – injected beam, 2 – ‘bumped’ one, 3 – circulated beam after first turn injection, 4 – after accumulation; BM 1  $\div$  3 – magnets for the bump formation, SM – injection septum magnet.

## BOOSTER MAGNETS

The magnetic system of the booster consists of 4 quadrants. There are 10 dipole magnets, 6 focusing and 6 defocusing lenses in each one. The multipole correctors are also used to compensate the errors of both main (dipole, quadrupole) and higher (sextupole, octupole) harmonics of the magnetic field. The needed magnetic field induction in aperture is 1.8 T at maximum rigidity (Table 3). The increased aperture of both lattice dipole and quadrupole magnets is one of the main design features.

Table 3. Lattice magnets

Dipoles	
Number of dipoles	40
Maximum magnetic field, T	1.8
Effective field length, m	2.2
Bending angle, deg	9.0
Curvature radius, m	14.09
Vacuum chamber, mm <sup>2</sup>	128 x 64
Quadrupoles	
Number of quadrupoles	48
Field gradient, T/m	19.7/-20.3
Effective field length, m	0.4

The requirements for dipole and quadrupole magnets of the Booster can be met using either – normal conducting or superconducting windings. The Nuclotron-type design based on a window-frame iron yoke and a saddle-shaped superconducting winding is chosen for the Booster.

The Nuclotron magnets include a cold (4.5K) window frame iron yoke and a superconducting winding made of a hollow NbTi composite superconducting cable cooled with two-phase helium flow at T=4.5 K [2]. A further development of the technology was proposed [3] to increase the efficiency of the magnetic system (Fig. 5).

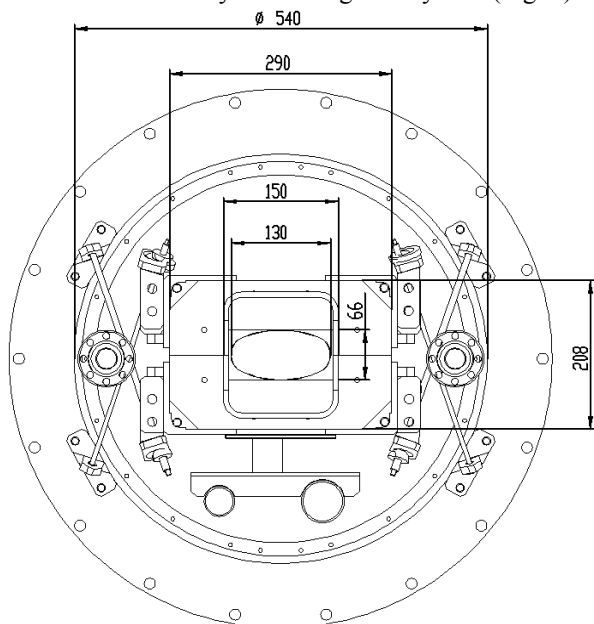

Fig. 5. Cross-section of the dipole magnet in cryostat.

In accordance with this proposal the single-layer winding bent dipole will be built to reduction the magnet cross section and AC losses in comparison with the straight double-layer winding dipole at the same aperture budget by means of the doubled structural current density in a winding. The use of curved (sector) dipoles instead of the straight ones in circular accelerators makes it possible to reduce the horizontal size of the magnet useful aperture that leads, in particular, to less AC losses.

## ELECTRON COOLING

An optimal energy value for electron cooling was chosen with account the following effects:

- 1) beam lifetime limitation due to interaction with the rest gas ;
- 2) beam lifetime limitation due to recombination on the cooling electrons;
- 3) space charge effects appearing due to ion beam shrinking at cooling;
- 4) sufficiently short cooling time ( $\leq 1$  sec);
- 5) space charge effect of electron beam on ion cooling;
- 6) an optimal use of the RF station;
- 7) cost of the electron cooler.

Numerical simulations of the cooling process showed that the cooling section of 4 m of the total length and electron current of 1 A provides required ion beam parameters at the ion energy of 100 MeV/u. The parameters are typical for conventional electron cooling systems, the energy corresponds to minimum range of the RF frequency variation (0.6 ÷ 2.4 MHz) during the Booster working cycle [4]. To adjust the cooling section with the SC magnetic system at minimum length, one plan to use a superconducting solenoid for the electron beam transportation, that is main technical peculiarity of the Booster cooler.

Design and construction of the Booster electron cooling system as well as the RF systems for the NICA rings will be provided in co-operation with BINP (Novosibirsk).

## REFERENCES

- [1] NICA Conceptual Design Report, JINR, January 2008. <http://www.jinr.ru/>
- [2] Khodzhibagiyan H.G., Smirnov A.A., The concept of a superconducting magnet system for the Nuclotron, *Proc. of the 12<sup>th</sup> Int. Cryogen. Eng. Conf.*, pp. 841-844, 1988.
- [3] H. Khodzhibagiyan, N. Agapov, A. Kovalenko, A. Smirnov, A. Starikov, Development of fast-cycling superconducting magnets at JINR» *Proc. of the CRYOPrague 06*, Prague, July 2006.
- [4] I.Meshkov, A.Sidorin, Electron cooling, NIM A 532 (2004), pp. 19-25.