

NUMERICAL ANALYSIS OF CAVITY MODE OPERATION AND ELECTRON BEAM DYNAMICS IN LEBEDEV INSTITUTE MICROTRON

V.S. Dyubkov, Yu.Yu. Lozeev, National Research Nuclear University MEPhI, Moscow, Russia
 Yu.A. Bashmakov, National Research Nuclear University MEPhI and P.N. Lebedev Physical Institute of the Russian Academy of Sciences, Moscow, Russia

Abstract

Dynamics of electrons in classic microtron is studied. 3D cavity model is developed and electromagnetic field distribution is simulated. Dependence of output beam parameters on microtron operation mode is investigated and discussed.

INTRODUCTION

The microtron is a circular resonance electron accelerator that was first proposed by V.I. Veksler in 1944 [1]. Electrons are accelerated in RF cavity located inside the magnet that forms a uniform time-constant field. Electrons, captured in synchronous acceleration mode, move in circles with stepwise increasing radii. Note all these circles theoretically have a common point that located inside the cavity. The main advantages of the microtron are extremely narrow energy spectrum and small sizes of accelerated beams [2,3]. Additionally, the microtron has relatively simple design and low cost of operation. Classical microtrons are used in variety application of science, industry and medicine. Thus, microtron is used as injector for electron synchrotrons with average energy is equal to (0.250 – 1.5) GeV [4,5]. It can be an effective source of high energy photon radiation in photon and neutron activation analysis. Microtrons can be used for photonuclear reaction production [6], as well as for neutron production for pulsed fast neutron reactor [7]. Today, one of the actual problems is a design of THz FEL based on microtron [8-10], one of the first realization attempts could date to the sixties of the last century.

NUMERICAL SIMULATION RESULTS

Electron dynamics simulation in 7 MeV Lebedev Physical Institute (LPI) microtron was carried out in present paper. This accelerator is an injector for 1.3 GeV "Pakhra" electron synchrotron (LPI). This microtron is also used to study bremsstrahlung characteristics of relativistic electrons in complex structures.

Circular cylindrical cavity based on the operating mode of E_{010} (TM_{010}) type at frequency of 2856 MHz is used as an accelerating element in LPI microtron. Electron source is a thermionic cathode mounted in a wall of the resonator (the so-called intracavity injection). LPI microtron is operated with the first type of acceleration [2,11,12]. The cavity cross section in microtron median plane is shown in Fig. 1. There are the basic geometric dimensions of the cavity in Fig. 1: radius (R), cavity length (d), distance between center of thermal emitter and the resonator axis (r_{emit}). Resonator geometry has a deviation from axially symmetric because of electron dynamics feature at the

first turns. We consider that cavity length d was equal to 19 mm. Note that $R = 0.383\lambda_{010}$, λ_{010} – wavelength for E_{010} mode.

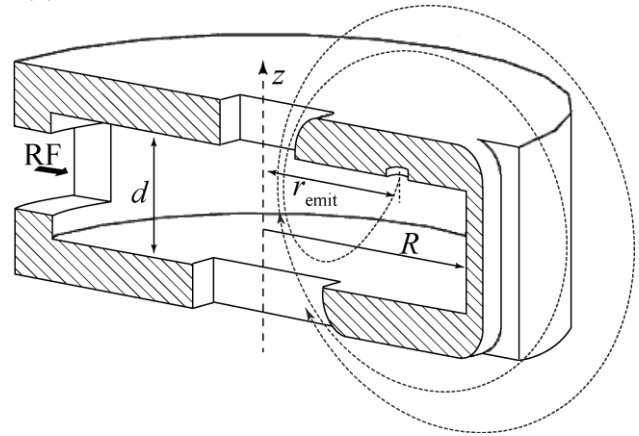

Figure 1: Cross-sectional view of RF cavity.

In the beginning 3D distribution of RF electromagnetic field (both electric and magnetic components) in microtron cavity was calculated by means of specialized code [13]. Typical spatial distribution of electric field absolute value in median plane is shown in Fig. 2. There are accelerating component of the cavity field as a function of longitudinal and transversal coordinates in Fig. 3 and Fig. 4 correspondingly.

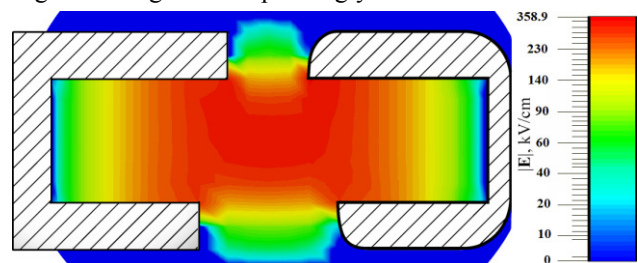

Figure 2: Typical spatial electric field distribution in median plane.

Further, dependence of output beam parameters on microtron operation mode, namely on amplitude of accelerating voltage, was investigated. In the first step it was written a special MICRO code that allowed us to carry out a two-dimensional one particle electron dynamics simulation in the field, calculated above, in microtron median plane. The energy of the emitted electrons was equal to 5 eV and r_{emit} was equal to 27 mm (shifted-emitter microtron). On simulating the electron dynamics we found that uniform magnetic field for circular motion is 0.12 T. Energy gain for one period is defined as follows

$$\Delta W_s = eU_0 T \cos \varphi_s$$

where U_0 is an accelerating voltage amplitude and transit-time factor is [14]

$$T = 2\sin(\theta/2)/\theta$$

and $\theta = \pi d/\lambda$. Note that in our case T is approximately equal to one. Thus, it was obtained that an amplitude of accelerating voltage should be equal to 660 kV in order to satisfy resonant acceleration condition.

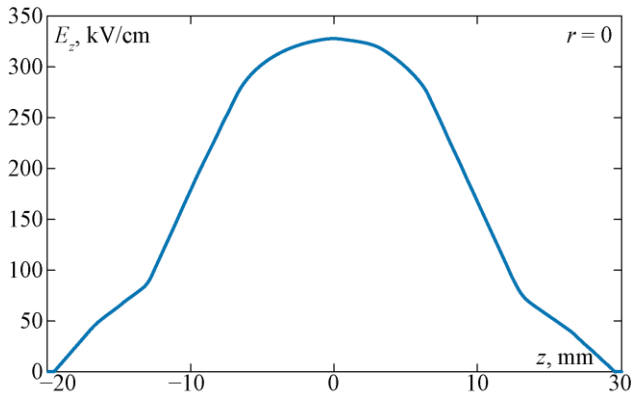

Figure 3: E_z vs z (cavity axis).

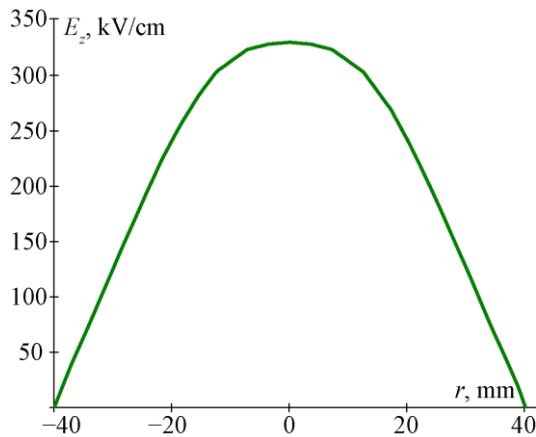

Figure 4: E_z vs r ($z = 0$).

There are several electron trajectories in Fig. 5. Each of them corresponds to different moments of electron emission from the thermionic cathode in the cavity field. One can see that a significant part of the electrons fall on the inner cavity wall and some part are lost on the outer cavity side.

In the second step 3D electron dynamics simulation in LPI microtron assuming continuous emission from thermionic cathode was carried out. Emitter spot diameter was presumed to be equal to 4 mm. For instance, dependence of normalized current on the 9th orbit on accelerating voltage amplitude is shown in Fig. 6. One can see that the maximal current value is achieved under amplitude value equal to 665 kV, but further 3D simulations have shown that this value is not optimal from the point of view of beam quality.

Thus, the optimal value of accelerating voltage amplitude is 660 kV. Dependences of electron beam core sizes on orbit number are shown in Fig. 7 and Fig. 8. As one can see from Fig. 7 & Fig. 8 the longitudinal beam size lies in the range from 2.5 mm to 4.8 mm and transversal one is not greater than 0.22 mm under chosen microtron parameters. The beam particles energy spectrum on the 9th orbit is shown in Fig. 9. There is a typical view of forming the electron bunches in Fig. 10. Note that half-width of energy spread of electron beam on the 9th orbit is about 0.3%.

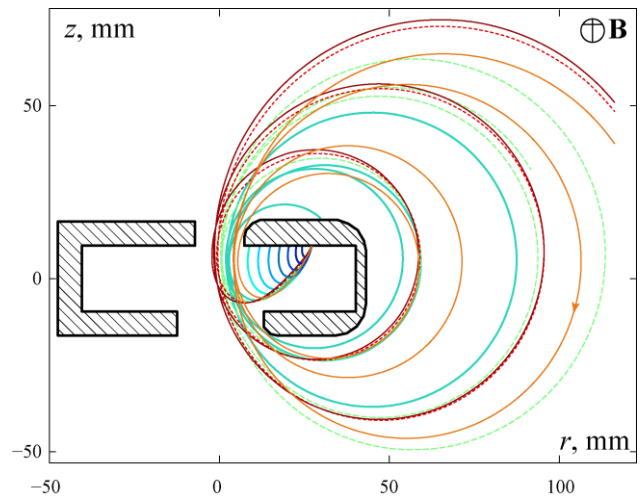

Figure 5: Typical trajectories of electrons in microtron.

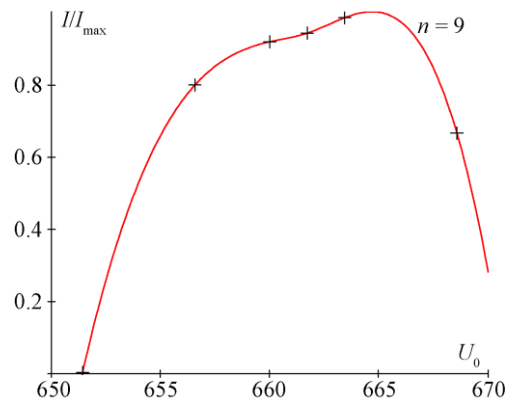

Figure 6: Normalized current on the 9th orbit vs accelerating voltage amplitude.

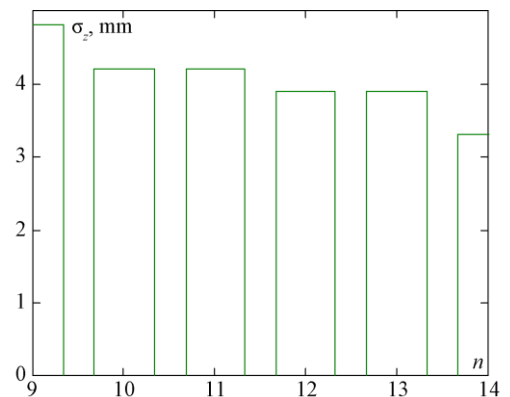

Figure 7: Longitudinal beam size vs orbit number.

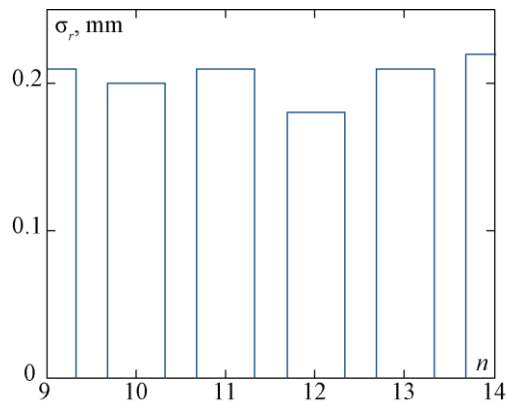

Figure 8: Transversal beam size vs orbit number.

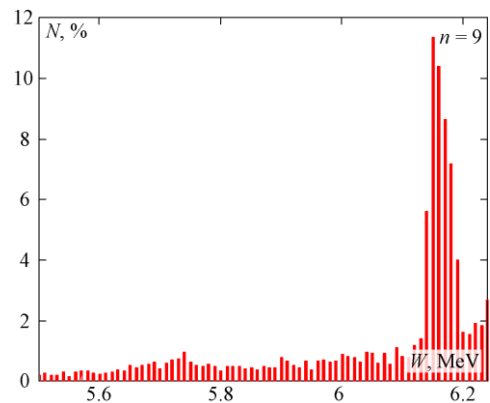

Figure 9: Particles energy spectrum on the 9th orbit.

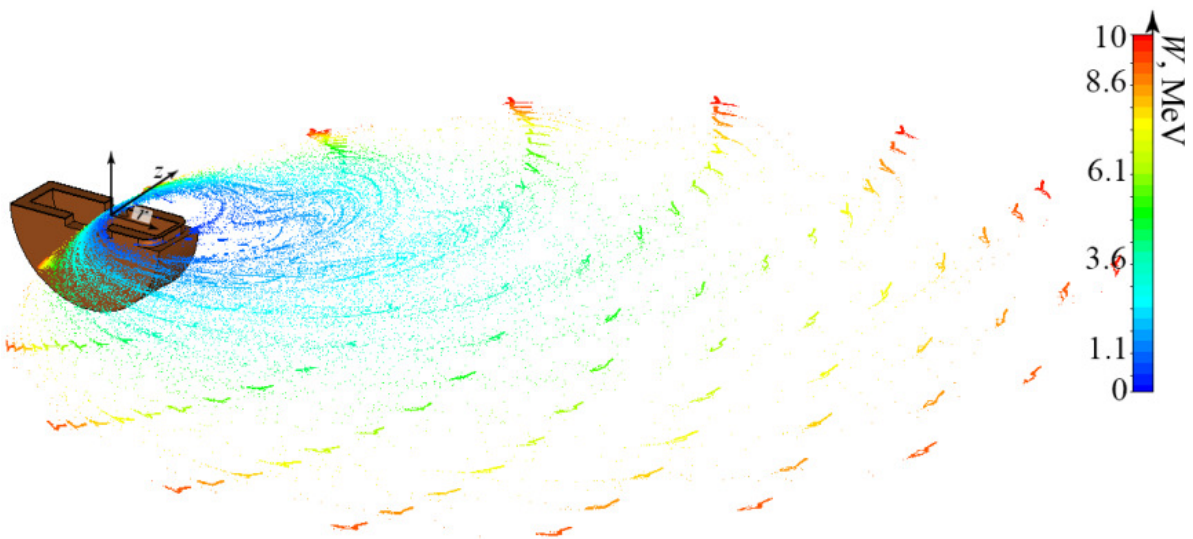

Figure 10: Typical view of forming the electron bunches in 3D space.

It was found that the maximal energy value is typical for particles that were emitted in phases of the RF field in the range approximately from -90° to -70° (for cosine voltage variation). Note also that approximately 65% of emitted particles hits the internal cavity wall during one period of RF field and only 20% are accelerated up to final energy which is equal to 10.9 MeV on the 18th orbit under magnet pole diameter is equal to 75 cm.

CONCLUSION

Dynamics of electrons in LPI microtron was studied. 3D cavity model was developed and electromagnetic field distribution was simulated. Dependence of output beam parameters on microtron operation mode was investigated. Optimal values of microtron parameters were found. It was shown that electrons can be accelerated up to 10.9 MeV under chosen parameters.

REFERENCES

[1] V.I. Veksler, Dokl. Ak. Nauk., J. Phys. USSR 9 (1945) 153

- [2] S.P. Kapitza, V.N. Melekhin, The Microtron (London: Harwood Academic Publishers, 1978), 204
- [3] Y.M. Tsipenyuk, S.P. Kapitza, The microtron: Development and applications (London: Taylor & Francis, 2002) 348
- [4] U. Bizzarri et al., Lettere al Nuovo Cimento 1(16) (1969) 820
- [5] V.G. Kurakin et al., "Automation of the Lebedev Physical Institute Synchrotron to the Energy 1.3 GeV as the First Stage of the Accelerator Upgrade", PAC'01, Chicago, June 2001, WPPH303 p. 2778 (2001); <http://accelconf.web.cern.ch/AccelConf/p01/PAPERS/WPPH303.PDF>
- [6] M. Kralik, et al. RSI 83 (2012) 083502
- [7] P. Krist et al., J. Radioanal. Nucl. Chem. 304 (2015) 183
- [8] S. Park et al., IEEE Transactions on Nuclear Sci. 63(2) (2016) 898
- [9] S. Park et al., J. Korean Phys. Society 66(3) (2015) 358
- [10] P.A. Cherenkov et al., NIM A 282(2) (1989) 436
- [11] K.A. Belovintsev et al., Soviet Atomic Energy 14(4) (1964) 364
- [12] G.G. Subbotin, A.V. Serov, LPI Preprint 19 (2007) 20070
- [13] www.ansys.com
- [14] A.P. Grinberg, Uspekhi Fiz. Nauk 75 (1961) 421