

Content from this work may be used under the terms of the CC BY 3.0 licence (© 2018). Any distribution of this work must maintain attribution to the author(s), title of the work, publisher, and DOI.

THE POWER SUPPLY OF PULSE MAGNETS WITH OUTPUT CURRENT UP TO 10 kA

V. Dokutovich[†], D. Senkov, D. Pureskin, A. Chernyakin
 Budker Institute of Nuclear physics SB RAS, Novosibirsk, Russia

Abstract

At the present stage of development of accelerating technology, it is important to create beam input and output systems for newly created and modernized cyclic accelerators. At the same time, high requirements associated with high energy beams of charged particles and a substantial length of channels are imposed both on the magnetic system of the transport channels and on power supplies. Within the framework of the construction of the NIKA (JINR)[1] accelerator complex, a channel for the transportation of the Buster-Nuclotron beam is created in BINP. A powerful precision source with an output current of up to 10 kA and an energy in the pulse of up to 23 kJ is designed to power impulse dipole lenses and septum magnets in channel.

The presented article describes a pulsed source for magnetic lenses with a maximum output voltage of up to 2 kV and a maximum output current of up to 10 kA. The stability of the current amplitude in the pulse is ensured at a level better than 10⁻³. In this case, the stability of the magnetic field in the lenses can be improved to a value of 100 ppm by introducing an additional feedback on the field of the magnet using the integrating ADC VsDC produced by BINP.

The developed source meets both the requirements for stability of output parameters and automation requirements for integration into modern accelerator systems.

INTRODUCTION

At the moment, the program for the construction of the Buster-Nuclotron bypass channel is being implemented within the framework of the NIKA project (Dubna) [2]. The BINP plays a significant role in the construction of the channel.

The structural scheme of the bypass channel is shown in Fig. 1. The channel consists of magnetic correctors and a septum of magnets.

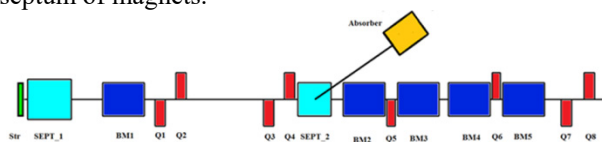

Figure 1: Magnetic system of the Buster-Nuclotron channel.

A high-voltage power supply is required to power the impulse dipole lenses (BM1-BM5) and the septum magnets (SEPT1, SEPT2, SEPT3), which would satisfy the following parameters in Table 1.

Table 1. Parameters Load

Parameter	dipole	septum 1	septum 2,3
Maximum current , kA	2	3	8
Pulse width , ms	30	0.1	1
Frequency, Hz	0,25	0,25	0,25
Maximum voltage, kV	2.1	1.6	1.6
maximum voltage, kV	10	16	60
Coil Resistance, mΩ	120	18	20
Storage capacity, μF	10	60	1600

Sources are built according to the scheme with a capacitive energy storage device, with its switching to the load and recuperation. In this regard, it has an increased efficiency. As management and diagnostics, a single-board computer is used that is responsible both for remote management and for manual and performing monitoring and protection functions.

STRUCTURE OF POWER SUPPLY

The structural diagram of the power supply is shown in Fig. 2. The operation of the power supply is based on the relatively long charging of the capacitor bank to the voltage of the required level through the "power inverter" and subsequent short-term discharge through the switch to the load. During the discharge process, a current pulse passes through the load, resembling a half-sinusoidal shape, and in amplitude it is many times larger than the charging current.

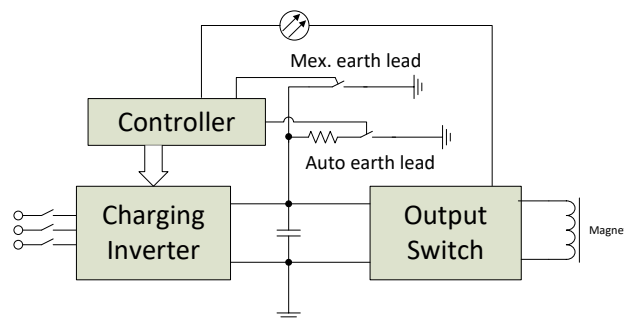

Figure 2: Structure of the power supply.

In the proposed sources, the amplitude value of the discharge current reaches 2 kA with the supply of a dipole

magnet and 8 kA when feeding a septum of magnets. When the currents reach the maximum value, the charged particles are transported from the Nuclotron to the Collider via the channel. Simultaneous achievement of maximum current and rigid synchronization of channels are very important. It is clear that the capacitor battery has the necessary energy intensity. It should also be designed for resistance to shock currents and the planned life cycle of the source.

It is the large energy capacity of the battery that forces us to introduce into the scheme an automatic earthman and a manual mechanical earthman. These elements serve to remove the charge from the capacitor bank and to ensure the safe operation of electrical personnel. Note that one of the poles of the battery must always be grounded.

Next, we will examine separately the functional blocks of the power supply.

Charging Inverter

The power part of the charging inverter is shown in Fig. 3. To charge the tank, a resonant inverter power supply is used, built on a bridge circuit using IGBT transistors with an output high-voltage transformer. The inverter operates at a frequency of 25kHz. The rectifier sections are connected in series, to ensure the operating voltage. The use of the resonance circuit makes it possible to simplify the control and charging system, since the large output inductance at the initial instants of time acts as a limiting primary charge current, allowing only the voltage feedback. In the future, the charger maintains the voltage on the capacitor bank, compensating for the loss of charge on the leakage currents.

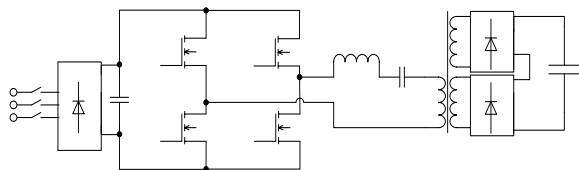

Figure 3: Power section of the charging inverter.

Output Switch

The source uses two types of output switches, depending on the applied inductance and the necessary pulse times.

The first type of output switch of a high-voltage source is a thyristor bridge (Fig. 4), controlled by fiberoptic drivers. The use of the bridge is due to the need to evacuate the energy stored in the magnet, back to the capacitive reservoir. The use of such a scheme allows, by choosing the opening time of the diagonals of the bridge, to form a linear portion at the peak of the current, and also not to recharge the capacitance from U to $-U$, thereby increasing the lifetime of the battery. The thyristor bridge operates in the following modes:

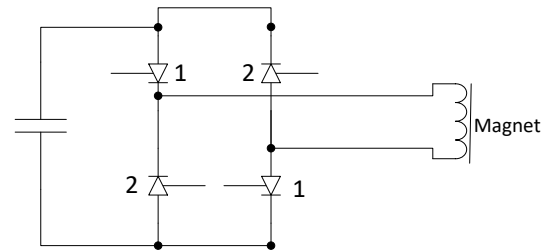

Figure 4: Power supply output stage for dipole magnets.

- **load switching mode**

When the control signal is applied, the first diagonal of the bridge is opened and the capacitance is switched to inductance, the current flow time is about 30 ms. When the capacitor voltage decreases to 0, the thyristors are closed spontaneously. And the work of the bridge goes into 2 mode.

- **recovery mode in capacity**

With the stored energy in the load inductance, the latter is a current source, opening a group of thyristors 2, the capacitor is charged, without changing the polarity on it. Emulation of voltage on the capacitance and current in the load is shown in Fig. 5.

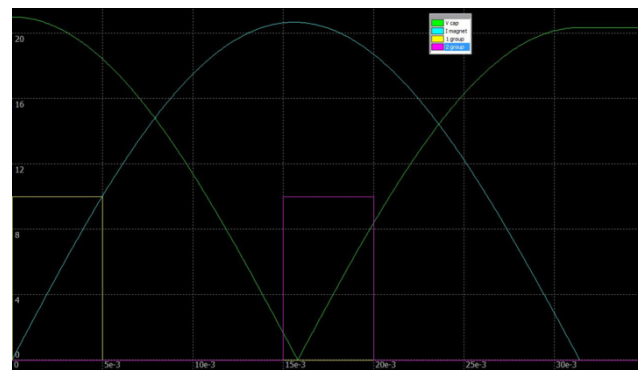

Figure 5: Emulation of voltage on the capacitance and current in the load.

The presence of a second type of output commutator is due to the fact that when feeding fast magnets with pulse times up to 1 ms, due to the time of opening the thyristor comparable with the time, it is impossible to realize the thyristor bridge circuit. The circuit of operation with one thyristor and one diode switched on in the opposite direction is realized (Fig. 6).

When this circuit is operating, the thyristor switching starts the oscillatory process in the circuit formed by the storage capacitance of the power supply and the inductance of the magnet. After a complete reversal of the voltage across the capacitor, when the voltage reaches a minimum, the reverse process starts due to the current flow-

Content from this work may be used under the terms of the CC BY 3.0 licence (© 2018). Any distribution of this work must maintain attribution to the author(s), title of the work, publisher, and DOI.

ing through the diode with a reverse charging of the capacitance.

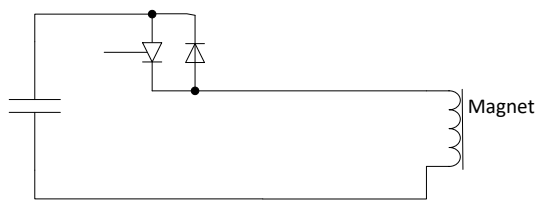

Figure 6: Power supply output stage for septum magnets.

By recuperating the energy back into the capacity of the charging converter, it is only necessary to compensate for energy losses on the active resistance of the magnet on the connecting path. Emulation of voltage on the capacitance and current in the load is shown in Fig. 7.

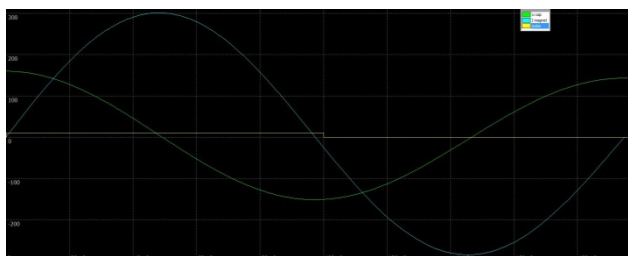

Figure 7: Emulation of voltage on the capacitance and current in the load.

Fast-Protection Device and Controller

In connection with the high output voltage and large stored energy, the issue of ensuring safety when operating and maintaining the source is acute. For these purposes, a security unit is implemented, located in a single module of the controller. The protections are divided into immediate actions, when triggered, an emergency shutdown occurs with the discharge of the storage tank to the protective resistance, and for protection against incorrect operation, due to which the load is diagnosed. In the latter case, it is possible to prevent the exit from standing both as a source and as a feed load. To ensure uninterrupted operation, the protection unit is made with high-voltage galvanic isolation at the inputs and outputs.

For remote control from the workstation and integration into the automated workstation complex, a controller is provided that works with the Ethernet network.

The circuit implementation of the controller with an integrated fast protection device eliminates the need for additional intra-block communication lines or interrogation, thereby improving the reliability of the source as a whole.

For local setup and diagnostics, local control is provided using a touch screen located on the front of the source. More details about him are told in a separate poster presented at the conference.

CONCLUSION

At the present moment there is a prototype production and evaporation to the final load. For subsequent delivery to its customer.

REFERENCES

- [1] A.N.Sissakian et al., “The Project NICA/MPD at JINR: Search for the Mixed Phase of Strongly Interacting Matter at Nuclotron-based Ion Collider Facility” XXIII International Symposium on Lepton and Photon Interactions at High Energy, LP07. August 13-18, Daegu, Korea. (2007),
- [2] NICA Conceptual Design Report, JINR, January 2008. <http://www.jinr.ru/>