

FUNDAMENTAL POWER COUPLERS FOR SUPERCONDUCTING CAVITIES*

Isidoro E. Campisi[†]

Thomas Jefferson National Accelerator Facility
Newport News, VA 23606, USA

Abstract

Fundamental power couplers (FPC's) for superconducting cavities must meet very strict requirements to perform at high power levels (hundreds of kilowatts) and in a variety of conditions (CW, pulsed, travelling wave, standing wave) without adversely affecting the performance of the cavities they are powering.

Producing good coupler designs and achieving operational performances in accelerator environments are challenging tasks that have traditionally involved large resources from many laboratories. The designs require state-of-the-art activities in RF, cryogenic and mechanical engineering, materials science, vacuum technology, and electromagnetic field modeling. Handling, assembly and conditioning procedures have been developed to achieve ever-increasing power levels and more reliable operation.

In this paper, the technical issues associated with the design, construction, assembly, processing and operation of FPC's will be reviewed, together with the progress in FPC activities in several laboratories during the past few years.

1 INTRODUCTION

Achieving ever-increasing accelerating gradients and lower and lower residual losses at high gradients is the main goal of RF superconductivity applied to particle accelerators.

However, in order to apply the successes of the research work on high gradients to real accelerator systems, many more and diverse problems need to be solved: the physics of resonators and their interaction with beams and the technological advances of their auxiliary systems must be taken into account.

Among the systems closely related to the cavities, none has a more crucial role for the successful application of RF superconductivity to accelerators than the fundamental power couplers (FPC's).

Efficient transfer of power from a generator to a "load" (cavity and beam) is the primary task of a coupler. From this perspective, a coupler can be considered as a properly designed transition in an otherwise perfectly matched transmission line, by which a properly determined energy admission rate can be delivered to the beam.

Even though most couplers do not make use of superconducting materials, the tight requirements imposed on them make the activities centered on FPC's as challenging as those for superconducting cavities. In addition, since any flaws of any components connected to the superconducting cavities can, and most likely will, degrade the cavity performance, the attention to the details of the design, fabrication and assembly of the couplers is at least as important as that for the cavities themselves. It is in fact known that, in general, cavity performance is often degraded between tests in a vertical Dewar and those in cryomodules. One of the components that can contribute to this degradation is the fundamental power coupler.

Work on fundamental power couplers has been at the forefront of technology for decades and several papers have addressed the issues related to these components before [1], [2], [3], [4], [5], [6], [7]. This paper will attempt to convey a sense of the variety of problems related to fundamental power couplers and the complexity of the solutions that scientists have come up with over the years.

2 GENERAL CONSIDERATIONS

The designs of FPC's are largely dictated by specific requirements associated with the characteristics of the cavities that are being powered. This discussion will mostly address accelerator applications and the issues related to high-power operation.

Traditionally, one of the attractive features of superconducting RF cavities has been the low losses that enable operation in CW with relatively high gradients and considerably lower dissipation than for normal-conducting cavities. So much so, that in some areas of accelerator physics, CW operation and pulsed operation have often in the past automatically identified one type of technology or the other. Accordingly, the parameters and the design requirements imposed on couplers have also been dictated by the average power levels and the peak power levels that the couplers would have to handle.

Recently, however, pulsed operation of superconducting cavities has been planned for or applied to new accelerators [TESLA, SNS], driven either by the basic requirements of the machine or by the need to achieve extremely high gradients without adversely affecting the ultimate cavity gradient performance. Accordingly, the types of problems that fundamental power couplers must deal with have expanded their parameter space. Whereas CW operation imposes tighter

* Supported by US DOE Contracts Nos. DE-AC05-00OR22725 and DE-AC05-84-ER40150

[†]campisi@jlab.org

requirements on the average power that the coupler must handle, the peak power requirements of pulsed systems can be just as demanding for other reasons. In this case, the transient fields in transmission lines and interfaces, in the absence or presence of beam, lead to additional complications due to the electrical, mechanical and thermal transients that the pulsed operation implies.

As superconducting cavities are applied to wider varieties of accelerators, the demands imposed on the couplers are also broadened and the designs and fabrications methods must follow the wider applications, in general bringing to the surface new problems to be solved, such as lower Q_{ext} , stronger coupling and more interference of the coupler with the cavity environment.

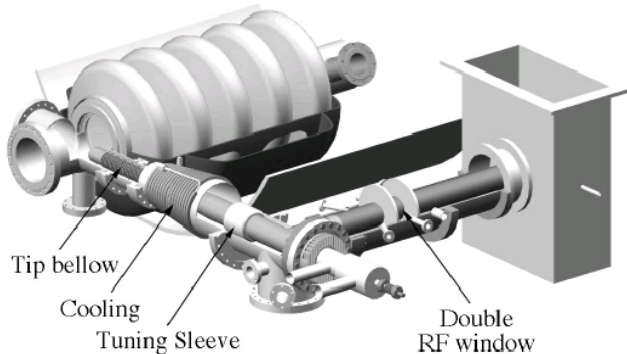

Figure 1. The fundamental power coupler for the APT incorporates several features of coaxial couplers: high power CW operation, variable coupling, active cooling of the outer conductor thermal transition and a double coaxial window at room temperature. [8]

Even from the purely RF point of view, couplers constitute rather complex systems, in which drastic field configuration changes occur over short distances, with inevitable field enhancements and perturbations to the cavity fields.

These facts alone imply a second-order complication for the proper design of cavity configurations, since local field perturbations could have significant effects on beam performance (e.g., beam kicks by asymmetric coupling schemes) and on superconducting cavity performance (e.g., field enhancement at coupling apertures which might locally bring field levels close to the superconductor's critical field if not properly designed or cooled, as in the case of coupling ports too close to the cells).

Transferring power between properly designed electromagnetic systems is, however, only the first and possibly the most straightforward step in designing couplers and in making them practical systems.

As a consequence of their proximity to superconducting cavities, most couplers must fulfill other roles, which substantially complicate their design and possibly limit their performance. Two of these "derived" or "secondary" functions include having to perform as 1) vacuum barriers between atmospheric pressure at room-temperature and low-temperature vacua at extremely (and often immeasurably) low pressures; and 2) as thermal

transitions between room-temperature RF transmission systems and the low-temperature superconducting cryogenic environment, with or without dynamic heat loading generated by the RF.

3 DESIGN OPTIONS

Fundamental power couplers can have different design characteristics and components, which are outlined in the following paragraphs.

3.1 Coupling: fixed vs. variable

Couplers for superconducting cavities can have broad ranges of coupling factors, spanning several orders of magnitude, and depending on the beam power that they have to support. In extremes cases of very low current machines [SDALINAC, RIA] external Q 's of 10^7 - 10^8 are used, whereas in high current accelerators, stronger couplings are necessary (10^5). In general, stronger couplings are more difficult to achieve, partly because of the inherently higher traveling power in the coupler, and partly because of the closer geometrical relationship of the coupler with the cavity, leading to higher field distortions near the coupler-cavity transition surfaces.

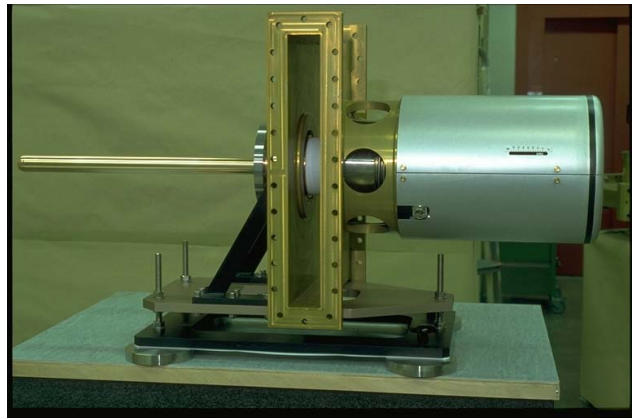

Figure 2. Variable coaxial coupler for the LHC. The variable insertion mechanism allows a change in coupling factor by over an order of magnitude. This coupler has a cylindrical window in the waveguide. [9]



Figure 3. Details of the center conductor of the APT coupler, with the BeCu bellows, which allow the coupling variation (upper left). [8]

Most accelerators have adopted a fixed coupling approach, since the operational beam current is fixed and the beam loading is well defined.

In a handful of cases, however, variable loading is too large to be dealt with just by RF controls, and variable coupling systems become necessary. Dealing with variable coupling creates challenging problems, which require innovative solutions. Recent tests of the APT coupler design have confirmed that a very careful execution of the design and of the assembly is necessary, to combine the variable coupling option with all the additional requirements typical of high-power operation.

3.2 Coupling: coaxial vs. waveguide

Of all the possible geometries for coupling to superconducting cavities, two main choices have been adopted: coaxial and waveguide coupling.

Waveguide coupling is conceptually simpler, since it does not require a transition between the waveguide, which usually carries the output power of the RF sources, and the cavity interface. This solution dates back to early stages of superconducting RF designs [10] and has been adopted in two accelerators now in operation (Cornell (CESR)/CEBAF, CESR-B, Figure 4). Due to the existence of a cutoff frequency in waveguides, the size of the coupler is generally larger at a given operating frequency than for the coaxial case. Because of the larger cross section of the coupling line, the contribution to the infrared heat transfer to the cryogenic environment is usually larger [11].

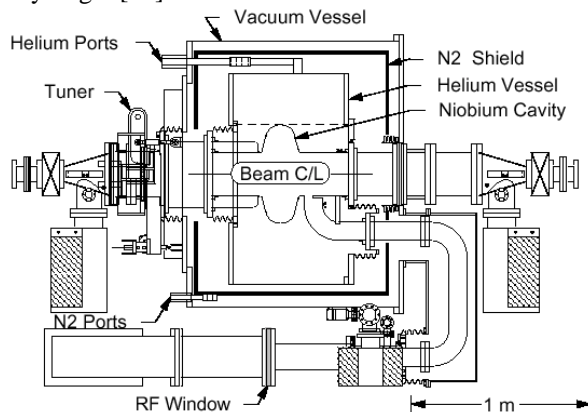

Figure 4. The CESR-B single cell cavity makes use of a waveguide coupler. This is the highest power waveguide coupler in operation, having reached close to 300 kW CW in operation with beam. [12]

The CEBAF upgrade project [13] will use waveguide coupling, and new design options for TESLA have been considered which involve waveguide coupling as well [14].

Not being limited by a cutoff frequency, coaxial couplers are in general more compact, especially for low frequency systems, and a variety of geometry and window arrangements are available to adapt to the specific need of

the system. Only power density considerations and suppression of multipacting levels play a role in determining the size of coaxial coupling systems.

3.2.1 Waveguide coupling

A few important features of the waveguide coupling systems deserve some mention here. A good review of some of these issues is found in [16].

Because of the waveguide geometry, windows for waveguide couplers are generally more difficult to manufacture and multiple windows within the waveguide's cross-section have been used [17].

The coupling strength can be adjusted in three basic ways: 1) by the size of the coupling iris, 2) by the longitudinal location of the waveguide with respect to the cavity's end cell, and 3) by the location of the terminating short of the waveguide itself, as in the case of CEBAF's cavities. Multipacting occurs in waveguides also and can be moderated by the use of magnetic field biasing. For superconducting systems, this biasing must occur at the locations of normal conducting parts of the transmission line [18], [19], [20].



Figure 5. Waveguide coupler for the CEBAF upgrade cavities: a single ceramic window at room temperature replaces the double windows present in the original CEBAF design. The high thermal gradients along the waveguide require a careful design. [15]

3.2.2 Coaxial coupling

Coaxial couplers offer one advantage: the impedance of the coaxial line can be chosen to be different from the standard 50 Ω , without modifying the coupler's outer dimensions and in order to modify the power levels at which multipacting can occur [21].

As in the case of the waveguide coupling, the coupling strength depends on the longitudinal location and the size of the coupling port, but in the case of electric coupling, a large range of coupling values can be achieved by proper insertion of the center conductor into the line.

Therefore proper matching can be easily obtained by changing only one parameter and variable coupling can be achieved with proper (if not simple) adjustment of the inner conductor.

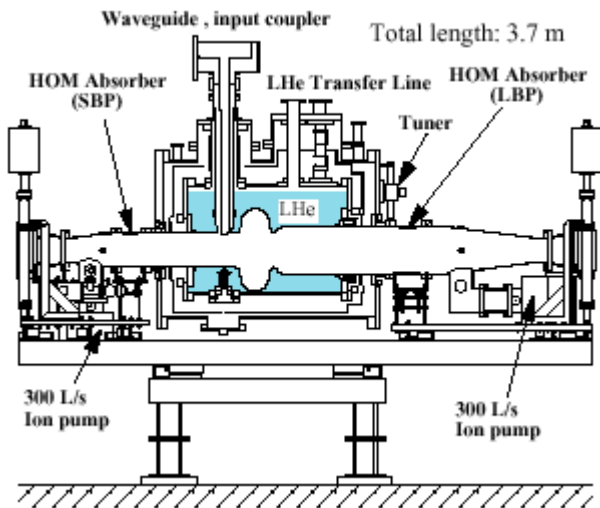

Figure 6. The KEK-B coupler is the coaxial counterpart of the CESR-B coupler. The design makes use of a single planar coaxial ceramic window at room temperature. Operation close to 400 kW has been achieved. [22], [23]

3.3 Windows

Windows are designed to separate the vacuum of the superconducting cavity from the atmospheric pressure of the transmission line. As electromagnetic interfaces, they must satisfy strict matching requirements, so that power is reflected and dissipated only in minute quantities. Since dielectric materials are used for the transmission of electromagnetic power [24], the manufacturing techniques usually involve complicated interfaces of conductors, dielectrics and brazing metals.

In addition, electronic phenomena at the windows can complicate the design. Multipacting at the windows can be particularly dangerous, as large amounts of power can be deposited in small areas of the dielectric, potentially leading to failure. Careful choice of geometry and coating with low secondary electron emission coefficient materials can mitigate this phenomenon [3].

Exposure to radiation can also lead to charging phenomena at the window surface [25], [26], [27], [28] leading to flashover of the accumulated charge and to damage of the window. Geometrical protection [27] as well as metallic films of proper thickness can be used to decrease the incidence of this problem.

As in the case of multipacting coating, it is essential that the appropriate thickness be carefully achieved (10-15 Å); otherwise excessive RF losses will occur and the subsequent excessive heating will lead to window failure [29].

In some cases, multiple windows in series are used (CEBAF: one window at 300 K and one at 2 K, the latter used for sealing cavity pairs as early as possible in the assembly process; TESLA: one room-temperature window and one at 70 K [30]; APT: two redundant room temperature windows for protection against failure) [8]. In spite of the added protection and some beneficial features,

multiple windows tend to complicate the design of the couplers, add cost and increase the number of critical components that can fail.

As mentioned above, windows for waveguide systems are usually planar and can occupy a large fraction of the waveguide cross-section, either in a single piece, or in multiple pieces [25], [31], [32], [33].

Coaxial windows are usually planar [8], [22], [34], [35] cylindrical [9], [36], [37] or conical [38].

Active pumping near the windows is desirable [6], [25] to avoid discharge problems during outgassing events associated with varying power levels, but in most cases design complications make this solution impossible and pumping is achieved only through the cavity itself. In this case, more careful initial conditioning and close attention to operational interlocks become even more necessary.

An excellent in depth study of RF windows is K. Cummings' dissertation [39].

3.4 Cooling

Coupler cooling is necessary to keep temperatures as constant as possible even in the presence of variable power. This prevents excessive infrared loading to the cryogenic environment and prevents excessive thermal gradients across ceramic windows, which might otherwise be fractured.

Waveguide couplers are usually not actively cooled, again thanks to the lower power densities, whereas coaxial couplers are actively cooled in a variety of ways: center conductors are cooled by water, or gases, whereas outer conductor transitions between the cryogenic and the room temperature environments are usually cooled by conduction [KEK-B] or by active helium gas cooling [APT, SNS].

Thermal intercepts at various temperatures (50-70 K) are used to limit the amount of heat load to the cryogenic environment.

3.5 Joints

Among the most complicated parts of any coupler is the design of proper joints. At these locations all of the complications and design features come together: the presence of dielectrics, metals, brazing alloys, RF matching requirements, metallic and dielectric losses, anti-multipacting and charge drainage films, outgassing considerations. Only very experienced designers are able to properly evaluate all these often-conflicting requirements and make a proper choice and compromise, which allow a nearly optimal performance of the coupler itself [3].

4 SIMULATIONS

Over the past several years an ever-increasing activity has been noticeable in the area of coupler design connected with simulations of various aspects of the coupler's performance. Thanks to better software tools, a larger and larger fraction of the design of couplers can be made well ahead of the actual construction, thus removing

part of the uncertainty of the coupler's performance and avoiding the lengthy, tedious and expensive work of cut and try, which is particularly demanding for systems connected to superconducting cavities.

4.1 Electromagnetic calculations

4.1.1 Field distribution

Programs such as HFSS have been used by several groups to evaluate the field distribution in couplers and transitions and to improve the matching at windows and at waveguide/coaxial transitions. Such calculations have been carried out, for example, for couplers designed at Saclay [40], [41], at LANL [42], [34], [43], [44], [45], for Cornell windows [32] and for the SNS coupler [46] (Figure 7)

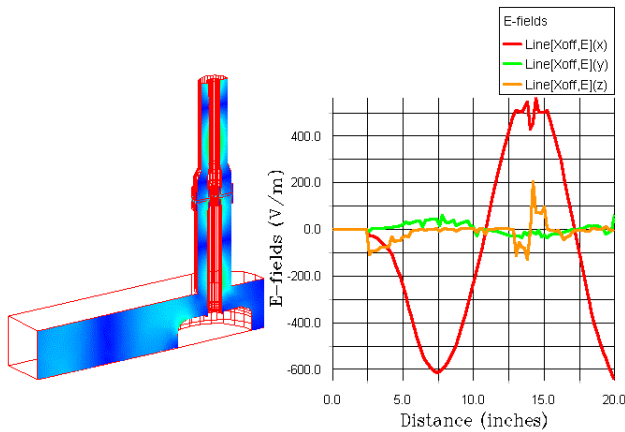

Figure 7. Electromagnetic field simulations allow better designs of coupler components: here the SNS waveguide-to-coaxial transition and the window matching section are shown with the relevant electric field strengths. [46]

4.1.2 External Q calculations

The coupler's external Q is a critical quantity, which needs to be set for each specific application. Calculations are also now routinely performed to determine the Q_{ext} in advance by matching cavity field calculations to the coupler's geometry field simulations. This has been done for the APT cavities [47], [48] and for the SNS [46]. In both cases bench measurements give extremely good agreement with the simulations.

4.1.3 Multipacting calculations

Along with better understanding of field distribution in couplers and with the improvement in tracking programs for multipacting in accelerating structures, a great improvement has been effected in understanding electronic activities inside the couplers' structures and in estimating location and magnitude of multipacting phenomena [49].

Such efforts have been carried out at Cornell for the waveguide geometry [19], [20], and at Saclay for various

window and coaxial geometries [40], [41], [50], [51], [45]. Activities in Finland in collaboration with TESLA and other laboratories have led to the study of the multipacting characteristics of several coupler geometries [52], [53], [54], [55]. From these studies a great deal of information has emerged which points to the fact that multipacting is generally unavoidable in couplers, as the amplitudes and phases of the forward and reverse wave change along various parts of the structure. Figure 9 gives an example of the output of the multipacting simulations. The final result of the simulations is that electromagnetic design alone is insufficient to avoid multipacting. Materials and surfaces must be carefully controlled and conditioning must be implemented in order to decrease the negative impact of this phenomenon.

As a side result of the multipacting simulations, it is now possible to design a proper biasing method in order to disrupt the multipacting orbits and their effects. Calculations with bias can be performed with the present multipacting modeling tools [56].

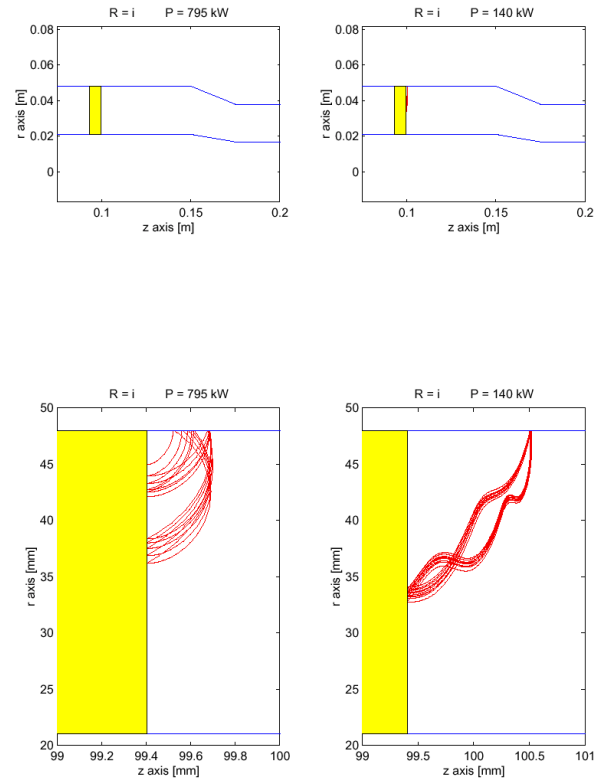

Figure 8. Multipacting simulations at the SNS coupler's window. The ability of predicting dangerous phenomena, like multipacting at specific locations in the couplers, leads to better designs. [54]

4.2 Thermal calculations

Another area where numerical calculations help in designing the coupler characteristics is the determination of the thermal properties. For coaxial geometry this has been done at the APT [57], [58] and at the SNS [35]. Both

center conductor and outer conductor thermal profiles can be determined in this way under RF loading conditions.

Similar calculations have been done for the waveguide geometry by other authors, taking into account the optimal length and thermal groundings to minimize cryogenic losses [15].

An area which requires additional attention is the modeling of the thermal profile of the coupler/cavity interface. Here the RF losses are small, but if the temperature is not properly stabilized, the superconductor's critical temperature could be exceeded due to the highly nonlinear losses caused by the thermal loading from the coupler.

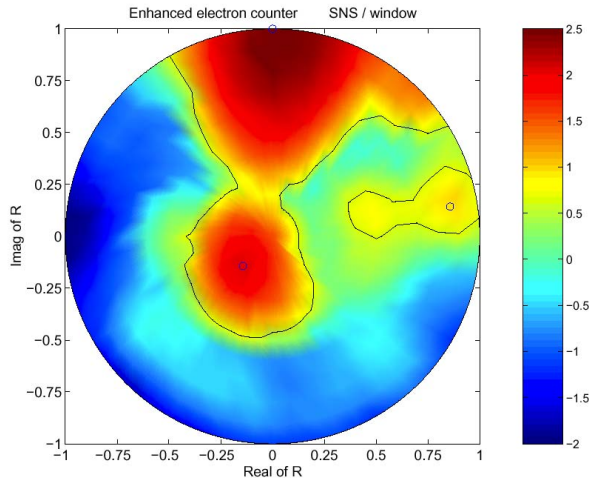

Figure 9. The results of multipacting simulations in couplers can be summarized by graphs like the one shown above: the red areas show regions of the complex reflection coefficient where multipacting can occur [54].

4.3 Mechanical stress calculations

Since some of the coupler designs rely on very delicate ceramic-to-metal brazing, it is important to evaluate the mechanical properties of the couplers to prevent costly mechanical failures.

Whereas in most cases couplers are assembled on the accelerator premises and a failure of a coupler in transit only affects the coupler itself, in the case of the SNS the assembly is done elsewhere from the installation point. A failure of a coupler during transit would have very costly consequences. In the future, this construction mode will become more and more frequent. Wilson [35] has evaluated the mechanical stresses on the SNS coupler, and the results indicate that the design should withstand the accelerations and stresses associated with the transfer from one laboratory to the other.

5 MATERIALS, MANUFACTURING, PREPARATION AND ASSEMBLY

The vast majority of superconducting cavities include only one or at most two materials (generally Nb, Cu, Pb, and NbTi for flanges) and, in spite of complicated

fabrication procedures, the manufacturing of such cavities includes a relatively small number of assembly processes. In the case of fundamental power couplers, however, a larger number of dissimilar components make up the final assembly and a larger number of materials need to be incorporated into the final product.

This creates a more complicated set of conditions, both in terms of mutual compatibility of the materials and in terms of the quality control needed at every step of the coupler production.

Typical metals used in the construction of couplers are stainless steel for the components that need to hold a large thermal gradient (e.g. outer conductors in coaxial couplers and waveguide penetrations into cryostats), often coated with copper for good RF performance and low RF losses; high-quality OFHC copper for room temperature components that need good thermal conduction (e.g. center conductors in coaxial couplers); BeCu components for variable couplers bellows [8].

High purity (>99%) and medium purity (95%) alumina, as well as beryllia and possibly aluminum nitride can be used for dielectric windows with proper metallization for brazing to the assembly [2], [3], [33].

Brazing alloys with suitable melting temperatures (often more than one brazing step is necessary) are used with joints positioned to avoid excessive RF losses.

Thin film coatings also require special development and equipment, and their application must occur at specific steps in the manufacturing sequence to prevent later damage of these delicate features. Coating of outer conductors or waveguides is done by sputtering or electroplating of copper, with or without intermediate layers. Ceramic coating with Ti or TiN (oxidized) for charge drainage and multipacting control is done mostly by sputtering [2], [3], [29], [59].

As in the case of superconducting cavities, the utmost attention must be given to ensuring clean assembly methods (electron beam welding, brazing, proper flanges capable of providing ultra-high vacua).

Achieving very clean surfaces in the couplers is as necessary as for superconducting cavities, since any contamination might either cause catastrophic failures of the couplers themselves, or directly cause contamination of the cavity surfaces. Moreover, a lack of cleanliness of the surfaces greatly increases the incidence of multipacting, thus increasing processing times, possibly limiting the ultimate performance and, in extreme cases, potentially leading to coupler failures. For coaxial couplers in particular, because of the complicated geometries and the presence of highly dissimilar and often incompatible materials, cleaning is a more complicated process than that of cavities, and only mild methods and cleaning agents are allowed in the final stages of fabrication and assembly. Poor quality control can lead to more frequent and less repairable failures than in the case of the cavities themselves.

Assembly of coupler components and of the couplers onto testing systems and cavities requires techniques and methods that are applicable to cavity assembly, with clean

room facilities and procedures that must guarantee the integrity of the assembly and the low contamination levels typical of high-gradient cavities.

All of the methods and systems described above entail labor-intensive activities, which require continuous quality control at each of the many manufacturing, cleaning, and testing steps. As a consequence, the cost of coupler manufacturing is presently very high, typically close to the cost of the cavities themselves, in the tens of thousands of dollars. For large systems, this high cost is unacceptable. While efforts are being made to decrease cavity costs through design changes and innovative manufacturing methods, not as much emphasis is being placed on trying to reduce coupler costs. Part of the problem is that each accelerator system being designed goes through at least a few iterations in reaching a satisfactory coupler design, driving the development costs very high. In some cases, successive versions of the same coupler gradually improve the performance, but so far not much attention has been given to trying to simplify the design and manufacturing methods in order to achieve considerable cost improvements.

Now that high performance couplers have been demonstrated to operate at hundreds of kilowatts and higher, the time has come to dedicate efforts to developing a class of couplers that not only perform at the present limits, but also do so with simplified designs and with considerably lower costs.

A concerted effort must be mounted in order to adopt common features from couplers that guarantee consistently high performance. A close interaction not only among laboratories, but also with industry, is necessary [32], [60], [61] from the early stages of the couplers' design in order to obtain the best performance for the lowest possible price.

In this direction, some efforts are being made by some companies, but increased activities in this area must be supported.

6 MEASUREMENTS AND TESTING

As a part of the many quality controls for couplers both in the developmental stages as well as in production, several types of measurements are necessary. The simulations mentioned above are a useful guide to predict the outcome of these measurements, but the latter are a necessary step in ensuring the proper coupler behavior and in understanding all the phenomena that will inevitably occur during real operation.

6.1 Matching

Matching measurements of individual components of the coupler (waveguides to coaxial transitions, window assemblies), and of components used in processing (connecting waveguides and cavities for coaxial couplers), must be done to ensure proper power transfer and minimize standing waves in the system. Full assembly matching measurements must be done at low power and

the results verified at high power to eliminate the possibility of detrimental electronic activities.

6.2 External Q

A measurement of Q_{ext} before installation of a coupler into a cavity is necessary to guarantee that the proper amount of power will be coupled to the cavity fields and to the beam during operation [46], [48].

Measurements of Q_{ext} at low temperature are very costly, since often the only way for the measurements to occur is in the final cryomodule configuration. A notable exception is the rapid cycling cryostat developed at Orsay [62], which enables several types of measurements related to superconducting cavities and auxiliary components with a turnaround time of days rather than several weeks or months. In this case, the measurement of Q_{ext} is straightforward, since in most superconducting cavity systems the coupling is so strong that a measurement of the loaded Q is equivalent to the measurement of the Q_{ext} .

In all other cases, bench measurements are necessary at room temperature. These are considerably more complicated and require the use of auxiliary probes, as done for HOM coupling measurements [63]. It is important that the probes (which need to be nearly critically coupled to the cavity fields) do not, at the same time, perturb the fields to the point that the coupling to the fundamental mode coupler is substantially modified.

6.3 Interlocks

In all the high power testing that is done, whether during processing or during testing in the cavities, a number of interlocks must be operative to prevent damage to the couplers or even catastrophic failures.

Whereas testing cavities by themselves (e.g. in vertical tests) requires minimal interlocks, the operation of high power couplers must include protections that prevent pressures from reaching the discharge limit; that prevent overheating of the coupler, especially with regard to the window itself; that monitor arcing that can occur at any location within the coupler vacuum; and that monitor the electron current near the windows. In fact, most of the interlocks commonly implemented in superconducting cavities are not for the cavity proper, but for protection of the complicated, and considerably more delicate, couplers [39].

7 PROCESSING AND CONDITIONING

Due to the general complexity of the couplers' structures and the tight requirements on outgassing which might contaminate the superconducting cavities, a thorough routine of processing and conditioning is necessary in advance of the installation of the couplers into the cavity assemblies.

7.1 Warm conditioning apparatus

Generally, coaxial couplers are processed in pairs, with the common vacuum guarded by the two windows. The

joining element is usually a section of waveguide properly matched at the coupler's main operating frequency, or by a room-temperature, normal-conducting cavity. In one case [54] a superconducting cavity has been used for testing couplers at high power.

Usually the processing stand consists of mechanical components that allow easy installation and pumping of the couplers and transferability to the appropriate high power source [65], [66], [67], [68], [8]. An independent vacuum pumping and monitoring system is necessary to guarantee the achievement of low pressures compatible with cavity installations. A baking system is often incorporated in the pumping stand.

As part of the apparatus, interlocks with properly designed controls are necessary to maintain the processing activity within predetermined parameters and to make the conditioning as automated and safe as possible.

High power sources are used, frequently providing powers higher than the operating sources, since, as a rule of thumb, it is desirable to reach power levels during conditioning at least twice as high as the highest possible power used during real operation.

In some cases cooling of the outer conductor is implemented, to more closely simulate the gas adsorption, and therefore the multipacting conditions, which are present during real operation [69], [70], [71].

7.2 Warm conditioning procedures

To simulate during processing the variety of phase and amplitude conditions encountered during real operation, all of the ranges of power levels and phases of the forward and reverse waves must be explored.

In order to reach the full average and peak power levels during processing, a systematic way of increasing the power must be followed in order not to create exceedingly high outgassing levels ($>10^{-7}$ torr) and thus avoid the consequent possibility of discharges, breakdowns and destructive conditions.

Typically, an initial procedure performed in a traveling wave mode includes the progressive increase of both power levels and pulse length in a pulsed mode. Depending on the coupler specific characteristics (designed for CW or pulsed), the procedure can be tailored to the coupler's needs. Experience plays an important role in the choice of procedure, but a careful attention to vacuum levels and to arcing activities is always necessary. Irreversible damage can occur if this is overlooked [72], [39], [28], [37], [73], [74], [23], [33].

During power ramping, multipacting levels can be encountered. In these cases, vacuum bursts are observed: these must be overcome by a slow increase in power or by the application of a biasing voltage (in the case of properly designed coaxial couplers) or the application of a magnetic field (for waveguide couplers).

Standing wave conditions are also routinely used to locally enhance the fields at different locations of the couplers and to simulate the effects occurring during power or beam transients.

7.3 In situ conditioning options

Even after thorough conditioning prior to installation into cavity systems, a great deal of care must be exercised once the coupler is installed in the cryomodule. A sudden application of power can, at this point, not only damage the coupler, but also jeopardize the operation of a whole accelerator.

Procedures have been developed which provide a gradual and controlled application of power to the couplers on and off resonance before the maximum operating power level is reached and before the attention is switched to the cavity operation [33]. In some cases this involves the use of pulsed power techniques to limit the average power and to achieve high field levels with amplitude and phases during the transient operation, which closely mimic the actual transients in the accelerator [75].

All of the conditioning procedures give results which might degrade with time. Both in room temperature conditioning and in actual operation it is necessary to re-establish safe operating power levels after every long shut-off or down time, whether the cavities have been warmed up or not.

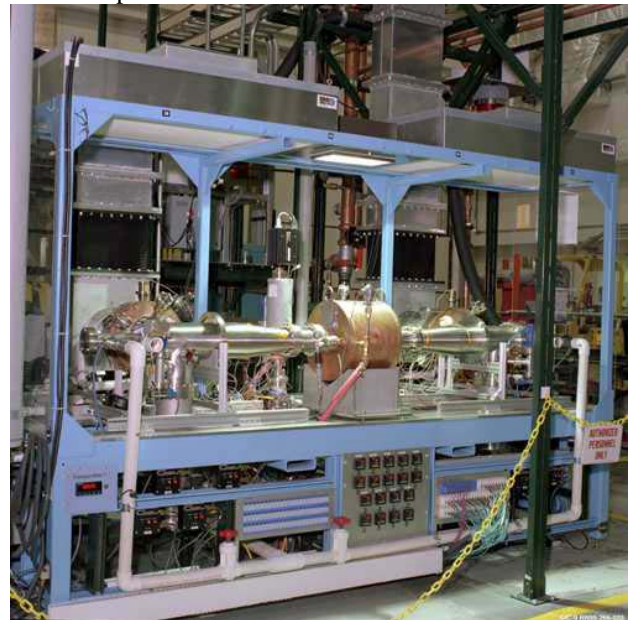

Figure 10. The-processing test stand of the APT couplers [8]. It incorporates a normal conducting cavity as a connecting element between couplers.

8 OPERATIONS

At the present time, only five superconducting machines with fundamental power couplers are in operation: KEK-B [76], CESR-B [12], HERA, TTF [77], [30] and CEBAF [78]. Two more machines have recently stopped operation: LEP [79] and the Jefferson Lab FEL, the latter in preparation for an upgrade.

Figure 11 shows the operating power reached by couplers in operation versus their operating frequency.

Operation at high power is now limited by overall machine parameters; it is encouraging to know that the

couplers being designed today can reach and possibly exceed the operating parameters which are now being used for the machine operations.

For all the accelerators, after initial commissioning of the couplers/cavities, in only a few cases have couplers been responsible for interruptions of machine operations.

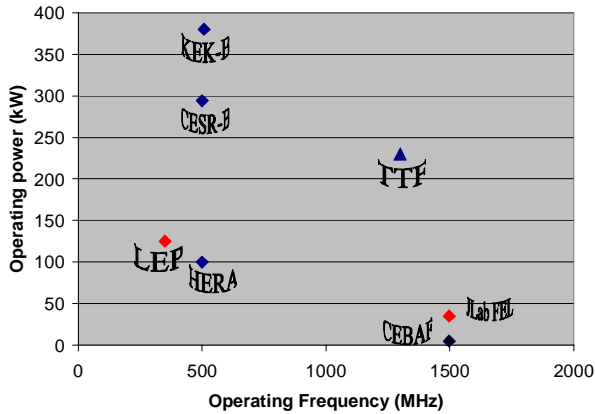

Figure 11. Operating power versus frequency for several superconducting machines' couplers. The red points are machines presently not in operation. The triangle is the peak power for the pulsed TTF. All others are CW-operated couplers.

9 PROGRESS REPORTS

Several projects at different stages of study or development have considered couplers of various designs.

The LHC has well-tested couplers, which have reached 300 kW in full reflection with cooled outer conductor for 200 hours. Previously, the coupler had reached 500 kW in traveling wave [9].

The APT has developed a coupler, which has reached over 1 MW in CW operation, with very encouraging operating parameters, which open the way for even more robust coupler designs [80], [81], [82].

Upgrades of both CEBAF and the Jefferson Lab FEL will require new windows/coaxial couplers capable of withstanding 100 kW CW in the immediate future and higher powers in the following years [15], [25].

TESLA [83] continues to develop improved versions of the original couplers and new waveguide coupling concepts [30], [14], also achieving higher and higher peak power levels [29].

Several proton machines [84], [85] now under consideration in Japan [86], [87], [88], [89], in Europe [45] and in the US [42] also have under development new designs and prototype couplers, which will expand the operating parameters.

Finally, the SNS, now in the final stages of development and soon under construction, has been able to benefit from the experience of all the laboratories previously involved in coupler development. In a short time the SNS fundamental power coupler (Figure 12) has gone from a concept to a tested prototype which has recently amply exceeded the design specifications [90], [91]. This coupler is the primary example of how the time

is now ripe for a true collaboration among various laboratories in order to develop jointly (and with the assistance of industry) a new class of couplers which will not only optimize the operating parameters, but will do so with a clear goal of decreasing the overall design, manufacturing, assembly and installation costs.

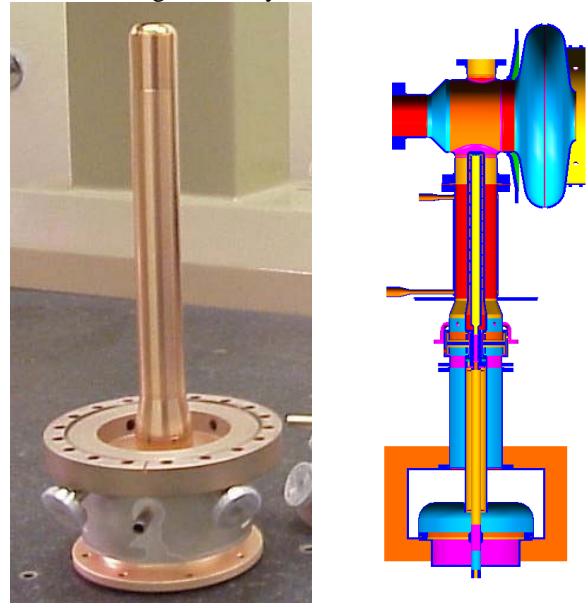

Figure 12. The SNS coupler is based on a modification of the KEK-B coupler. The window matching design has been applied in the past to room-temperature systems. The SNS coupler developments has greatly benefited from the experience and the collaborations of several laboratories and industries around the world and has reached 2 MW peak in high-power tests [91].

10 SUMMARY AND CONCLUSIONS

Fundamental power couplers for superconducting cavities are among the most important and most complicated auxiliary systems in superconducting particle accelerators. Great progress has been made recently in achieving high power transfer to beams in real operating conditions and in preliminary tests of several other couplers in various stages of development.

In the future, couplers with higher and higher power handling capabilities will be necessary for more powerful machines, and the development of new couplers must capitalize as much as possible on past experience, on simulation methods and on better manufacturing practices, which will need to cut costs to make large-scale adoption of superconducting cavity technology possible.

The development of reliable and inexpensive couplers must go hand in hand with the development of better accelerating structures for the technology to be widely applicable.

Even though most couplers do not make use of superconductors, the technologies involved in the construction of couplers are as challenging (and possibly more so) than those used for the development of superconducting cavities.

The community must pay close attention to the issues related to the development of couplers for the future of superconducting RF technology to be widely applied to many systems.

11 ACKNOWLEDGEMENTS

The author would like to thank M. Stirbet, P. Kneisel, K. M. Wilson, E. Daly, J. Henry, T. Powers, M. Drury, G. K. Davis, L. King, W. Sommer, S. Castagnola, C. Grenoble, K. C. Chan, B. Rusnak, C. Travier, S. Noguchi, S. Mitsunobu, T. Furuya, N. Ouchi, M. Matsuoka, D. Rees, T. Hardek, E. Schmierer, K. Cummings, M. Champion, Y. Kang, S.-H. Kim, M. Doleans, P. Ylä-Oijala, H.-D. Graef, D. Kostin, W.-D. Moeller, B. Dwersteg, S. Belomestnykh, H.-P. Kindermann, O. Brunner, G. Bisoffi, T. Garvey, for kindly providing information for this paper.

12 REFERENCES

- [1] R. M. Sundelin, "Joints, Couplers, and Tuners", Proc. First Workshop on RF Superconductivity, Karlsruhe, Germany, July 1980, p. 246.
- [2] B. Dwersteg, "High Power Couplers", 4th Workshop on RF Superconductivity, p. 351.
- [3] H. L. Phillips, "An Update on Windows, Couplers, Higher-Order-Mode Damping, and Interlocks", 6th Workshop on RF superconductivity, p. 267.
- [4] E. Haebel, "Couplers for cavities," CERN Accelerator School: Superconductivity in Particle Accelerators, Hamburg, Germany, May 1995, p. 231.
- [5] M. Champion, "RF Input Couplers and Windows; Performances, Limitations, and Recent Developments", 7th Workshop on RF Superconductivity, p. 195.
- [6] E. Haebel, "Power Couplers: Sources and Consequences of Mismatches", 8th Workshop on RF Superconductivity, p. 725.
- [7] H. Matsumoto, "High Power Coupler Issues in Normal Conducting and superconducting Accelerator Applications", PAC99, p. 536.
- [8] K. C. D. Chan, "Executive Summary of the Final Report on the APT Power Coupler Engineering Development and Demonstration (ED&D) Activities", LANL Report, 1998.
- [9] H. Kindermann, M. Stirbet, "The Variable Power Coupler for the LHC Superconducting Cavity", 9th Workshop on RF Superconductivity, p. 566.
- [10] W. B. Herrmannsfeldt (Ed.), "Feasibility Study for a Two-Mile Superconducting Accelerator", SLAC, 1969, Sect. V.B-4
- [11] N. Jacobsen and E. Chojnacki, "Infra-Red Propagation Through Various Waveguide Inner Surface Geometries" Cornell University, SRF 990301-01, 1999.
- [12] S. Belomestnykh and H. Padamsee, "Performance of the CESR superconducting RF System and Future Plans", These Proceedings.
- [13] J. R. Delaven, L.R. Doolittle, T. Hiatt, J. Hogan, J. Mammosser, L. Phillips, J. Preble, W.J. Schneider, G. Wu, "An R.F. Input Coupler System for the CEBAF Energy Upgrade Cryomodule", PAC99, p. 1462.
- [14] B. Dwersteg, D. Kostin and W.-D. Moeller, "TESLA RF Couplers Development at DESY", These Proceedings.
- [15] T. Hiatt, M. Breth, M. Drury, R. Getz, L. Phillips, J. Preble, J. Takacs, W. Schneider, H. Whitehead, M. Wiseman and G. Wu, "Cryogenic Testing of the RF Input Waveguide for the CEBAF Upgrade Cryomodule", PAC 2001, Chicago, USA, June 18-22, 2001.
- [16] L. R. Doolittle, "Strategies for Waveguide Coupling for SRF Cavities", Linac98, p. 246.
- [17] D. Metzger, P. Barnes, A. Helser, J. Kirchgessner, H. Padamsee, "Test results and Design Considerations for a 500 MHz, 500 kW Vacuum Window for CESR-B" PAC93, p. 1399.
- [18] E. Chojnacki, S. Belomestnykh, "RF Power Coupler Performance at CESR and Study of a Multipactor Inhibited Coupler", 9th Workshop on RF Superconductivity, p. 560.
- [19] R. L. Geng, H. Padamsee, "Exploring Multipacting Characteristics do a Rectangular Waveguide", PAC99, p. 429.
- [20] R. L. Geng, H. Padamsee, V. Shemelin, "Multipacting in a Rectangular Waveguide", PAC 2001, Chicago, USA, June 18-22, 2001
- [21] E. Somersalo, P. Ylä-Oijala, D. Proch, "Analysis of Multipacting in Coaxial Lines", PAC95, p. 1500.
- [22] S. Mitsunobu, T. Furuya, T. Tajima, T. Kijima, T. Tanaka, "High Power Input Coupler for KEKB SC Cavity," 9th Workshop on RF Superconductivity, p. 505.
- [23] Y. Kijima, S. Mitsunobu, T. Furuya, T. Tajima, T. Tanaka, "Input Coupler of Superconducting Cavities for KEK-B", EPAC 2000, p. 2040.
- [24] B. Dwersteg and Y. Zhenze, "Measuring Complex Dielectric Constant of Aluminum Oxide Window Ceramics for TTF Power Couplers at DESY", These Proceedings.
- [25] L. Phillips, J. Mammosser, and V. Nguyen, "New Window Design Options for CEBAF Energy Upgrade" PAC97, p. 3102.
- [26] L. Phillips, C. Reece, T. Powers, V. Nguyen-Tuong, "Some Operational Characteristics of CEBAF RF Windows at 2 K", PAC93, p. 1007.
- [27] S. Chel, M. Desmons, C. Travier, T. Garvey, P. Lepercq, R. Panvier, "Coaxial Disk Windows for High Power Superconducting Cavities Input Coupler", PAC99, p. 916.
- [28] C. Travier, S. Chel, M. Desmons, G. Devanz, P. Lepercq, T. Garvey, "Design and Test of a 1.3 GHz Travelling Wave Window", 9th Workshop on RF Superconductivity, p. 427.
- [29] J. Lorkiewicz, B. Dwersteg, A. Brinkmann, W. -D. Moeller, D. Kostin, M. Layalan, "Surface TiN Coating of TESLA Couplers at DESY as an Antimultipactor Remedy", These Proceedings.
- [30] W. -D. Moeller, "High-Power Coupler for TESLA Test Facility", 9th Workshop on RF Superconductivity, p. 577.
- [31] V. Nguyen, H. L. Phillips, and J. Preble, "Development of a 50 kW CW L-band rectangular

- Window for the Jefferson Lab FEL Cryomodule”, PAC99, p. 1459.
- [32] E. Chojnacki, T. Hays, J. Kirchgessner, H. Padamsee, M. Cole and T. Schultheiss, “Design of ea High Average power Waveguide Window”, PAC97, p. 3177.
- [33] E. Chojnacki, P. Barnes, S. Belomestnykh, R. Kaplan, J. Kirchgessner, H. Padamsee, P. Quigley, J. Reilly, and J. Sears, “Tests and Designs of High-Power Waveguide Vacuum Windows at Cornell”, 8th Workshop on RF Superconductivity, p. 753.
- [34] F. Krawczyk J. Gioia, B. Haynes, R. Lujan, B. Rusnak, B. Smith, “The Power Coupler Design for the APT Superconducting Accelerator,” 8th Workshop on RF Superconductivity, p. 762.
- [35] I. E. Campisi, E. F. Daly, J. E. Henry, P. Kneisel, W. J. Schneider, M. Stirbet, K. M. Wilson, “The Fundamental Power Coupler Prototype for the Spallation Neutron Source (SNS) Superconducting Cavities,” PAC 2001, Chicago, USA, June 18-22, 2001.
- [36] M. Champion, “Input Coupler and Windows for TESLA”, 6th Workshop on RF Superconductivity, p. 406.
- [37] H.P. Kindermann, E. Haebel, M. Stirbet, V. Veshcherevich, “Status of RF Power Couplers for Superconducting Cavities at CERN”, EPAC 96, p. 2091.
- [38] M. Champion, D. Peterson, T. Peterson, C. Reid, M. Ruschman, “TESLA Input Coupler Development”, PAC 93, p. 809.
- [39] K. A. Cummings, “Theoretical Predictions and Experimental Assessment of the Performance of Alumina RF Windows”, Ph.D. Dissertation, LANL Report LA-13466-T, July 1998.
- [40] X. Hanus, A. Mosnier, “Coaxial TW window for power couplers multipactor considerations”, 7th Workshop on RF Superconductivity, p. 701.
- [41] S. Chel, M. Desmons, C. Dupery, X. Hanus, A. Mosnier, G. Bienvenu, J. C. Bourdon, T. Garvey, J. Le Duff, J. Marini, G. Mace, R. Panvier, N. Solyak; A. le Goff, S. Maïssa, T. Junquera, “Power coupler development for superconducting cavities”, EPAC96, p. 2088.
- [42] E. N. Schmierer, K. C. D. Chan, R. C. Gentzlinger, W. B. Haynes, F. L. Krawczyk, D. I. Montoya, P. L. Roybal, D. L. Schrage, T. Tajima, “Design of the ADTF Spoke Cavity ED&D Input Coupler”, These Proceedings.
- [43] G. Spalek and J. Kuzminski” High Power Variable Couplers for Ladder and Spoke Type Resonators”, PAC 2001, Chicago, USA, June 18-22, 2001.
- [44] E. Schmierer, R. E. Lujan, B. Rusnak, B.G. Smith W. B. Haynes, D. C. Gautier, J. Waynert, F. L. Krawczyk, J. G. Gioia, “Development of the SCRF Power Coupler for the APT Accelerator”, PAC99, p. 977.
- [45] G. Devanz, H. Safa, C. Travier, “Preliminary Design of a 704 MHz Power Coupler for a High Intensity Linear Accelerator”, EPAC 2000, p. 2031.
- [46] Y. Kang, S. Kim, M. Doleans, I. E. Campisi, M. Stirbet, P. Kneisel, G. Ciovati, G. Wu, P. Ylä-Oijala, “Electromagnetic Simulations and Properties of the Fundamental Power Couplers for the SNS Superconducting Cavities,” PAC 2001, Chicago, USA, June 18-22, 2001.
- [47] P. Balleyguier, “A straightforward method for cavity external Q computation”, Particle Accelerators, Vol. 57, p 113, 1997.
- [48] P. Balleyguier, “External Q Studies for APT SC-Cavity Couplers”, Linac98, p. 133.
- [49] F. L. Krawczyk, “ Status of Multipacting Simulation Capabilities for SCRF Applications”, These Proceedings.
- [50] G. Devanz, “Multipactor simulations in superconducting cavities and power couplers”, Phys. Rev. Special Topics- Accelerators and Beams, Vol. 4, 012001 (2001)
- [51] G. Devanz, “A 2D Multipactor Simulation Code for RF Components and Accelerating Cavities”, EPAC 2000
- [52] E. Somersalo, P. Ylä-Oijala, D. Proch, “Electron multipacting in RF structures”, DESY Print TESLA 94-4, July 94.
- [53] P. Ylä-Oijala, “Analysis of Electron Multipacting in Coaxial Lines with Traveling and Mixed Waves”, TESLA Report 97-20, 1997.
- [54] P. Ylä-Oijala and M. Ukkola, “Multipacting Simulations on the Coaxial SNS Coupler”, University of Helsinki Report, November 2000.
- [55] P. Ylä-Oijala and D. Proch, “MultiPac-Multipacting simulation package with 2D FEM Field Solver”, These Proceedings.
- [56] P. Ylä-Oijala, “Suppressing Electron multipacting in Coaxial Lines by DC Voltage”, TESLA Report 97-21, 1997.
- [57] R. Bourque and G. Laughon, ”Thermal Analysis of a Refined APT Power Coupler and Thermal Shield and the Effect on the Cryoplant”, PAC 2001, Chicago, USA, June 18-22, 2001.
- [58] J. A. Waynert and F. C. Prenger, “A thermal analysis and Optimization of the APT 210 kW Power Coupler”, Linac98, p. 950.
- [59] Y. Kijima, S. Mitsunobu, and R. Noer, “The Secondary Electron Coefficient of the material for the Input Coupler on KEK-B superconducting Cavity”, These Proceedings.
- [60] S. Bauer, B. Griep, M. Peiniger, M. Pekeler, C. Piel, P. Vom Stein, H. Vogel, “SRF Technology at ACCEL for Worldwide Accelerator Projects”, These Proceedings.
- [61] AMAC and CPI are collaborating on a DOE grant to produce new window schemes.
- [62] S. Bousson, “Overview of Superconducting RF Activities at IPN”, These Proceedings.
- [63] G. Ciovati, I. E. Campisi, S.-H. Kim, P. Kneisel, J. Sekutowicz, R. Sundelin, “HOM Measurement Techniques and Results for the SNS Cavities”, JLAB Technote, 2002.
- [64] H.-P. Kindermann and M. Stirbet. “RF power tests of LEP2 couplers on a single cell superconducting cavity” 8th Workshop on RF Superconductivity, p. 732.
- [65] S. Chel, M. Desmons, C. Travier, T. Garvey, P. Lepercq, R. Panvier, S. Bulher, G. Guillier, “Status of the TESLA Power Coupler Development Programme in France”, EPAC98, p. 1882.

- [66] M. Stirbet, I. E. Campisi, G. K. Davis, M. Drury, C. Grenoble, G. Myneni, T. Powers, K. M. Wilson, "Processing Test Stand for the Fundamental Power Couplers of the Spallation Neutron Source (SNS) Superconducting Cavities," PAC 2001, Chicago, USA, June 18-22, 2001.
- [67] R. Bibeau, B. Campbell, D. Chan, M. Cola, K. Cummings, R. Edwards, G. Ellis, C. Gautier, B. Gentzlinger, J. Gioia, W. B. Haynes, D. Katonak, J. P. Kelley, F. L. Krawczyk, R. Lujan, R. Lujan, M. Madrid, R. Mitchell, D. Montoya, E. Newman, W. Roybal, E. Schmierer, A. Shapiro, B. Smith, R. Valicenti, J. Waynert, B. Rusnak, S. Shen, R. Walsh, "Status of the LANL Activities in the Field of RF Superconductivity", 9th Workshop on RF Superconductivity, p. 46.
- [68] J. Gioia, K. Cummings, C. Gautier, T. Hargenrater, W. B. Haynes, F. L. Krawczyk, M. Madrid, W. Roybal, B. Rusnak, E. N., Schmierer, B. Smith, R. Zimmerman, K. Kishiyama, S. Shen, H. Safa, "A Room Temperature Test Bed for Evaluating 700-MHz RF Windows and Power Couplers for the Superconducting Cavities of the APT Linac," PAC99, p. 983.
- [69] E. Haebel, H.-P. Kindermann, M. Stirbet, V. Veshcherevich, and C. Wyss, "Gas condensation on cold surfaces, a source of multipacting discharges in the LEP2 power coupler", 7th Workshop on RF Superconductivity, p. 707.
- [70] R. L. Geng, H. Padamsee, "Condensation/Adsorption and evacuation of residual Gases in the SRF System for the CESR Luminosity Upgrade", PAC99, p. 983.
- [71] Y. Kijima, S. Mitsunobu, and T. Furuya, "The Conditioning of the Input Coupler for KEK-B superconducting Cavity", These Proceedings.
- [72] M. Stirbet, I. E. Campisi, E. F. Daly, G. K. Davis, M. Drury, P. Kneisel, G. Myneni, T. Powers, W. J. Schneider, K. M. Wilson, Y. Kang, K. A. Cummings, T. Hardek, "Testing Procedures and Results for the Spallation Neutron Source Fundamental Power Coupler," PAC 2001, Chicago, USA, June 18-22, 2001.
- [73] K. Cummings, R. Cordova, D. Rees, W. Roybal, S. Risbud, and D. Wilcox, "Results and Lessons Learned from Conditioning 1 MW CW 350 MHz Coaxial Vacuum Windows", Linac98, p. 938.
- [74] S. Mitsunobu, K. Asano, T. Furuya, Y. Ishi, Y. Kijima, K. Sennyu, T. Tajima, T. Takahashi and S. Zhao, "Status and Development of Superconducting Cavity for KEK-B", PAC97, p. 2908.
- [75] I. E. Campisi, "Power Requirements for Pulse Peak Power Processing of CEBAF cavities", CEBAF Technical Note TN-95-007, February 1995.
- [76] S. Mitsunobu. "Operating Experience of KEK-B Factory Superconducting Cavity", These Proceedings.
- [77] A. Matheisen, "Status of the RF Superconductivity Activities at DESY", These Proceedings.
- [78] C. Reece, "Overview of the SRF-Related Activities at Jefferson Lab" These Proceedings.
- [79] P. Brown, O. Brunner, A. Butterworth, E. Ciapala, H. Frischholz, G. Geschonke, E. Peschardt, and J. P. H. Sladen, "Operating Experience with the LEP200 Superconducting RF system", These Proceedings.
- [80] E. N. Schmierer, W. B. Haynes, F. L. Krawczyk, D. C. Gautier, J. G. Gioia, M. A. Madrid, R. E. Lujan, K. C. D. Chan; B. Rusnak, "Testing Status of the Superconducting RF Power Coupler for the APT Accelerator", 9th Workshop on RF Superconductivity, p. 570.
- [81] E. Schmierer, W. B. Haynes, F. L. Krawczyk, D. C. Gautier, J. G. Gioia, M. A. Madrid, R. E. Lujan, K. C. D. Chan, D. Schrage, B.G. Smith, J. Waynert and B. Rusnak, "Results of the APT Power Coupler Development for superconducting Linacs", These Proceedings.
- [82] E. N. Schmierer, W. B. Haynes, F. L. Krawczyk, D. C. Gautier, J. G. Gioia, M. A. Madrid, R. E. Lujan, K. C. D. Chan, D. Schrage, B. G. Smith, J. Waynert; B. Rusnak; "Results of the APT RF Power Coupler Development for Superconducting Linacs", PAC2001, Chicago, IL, June 2001
- [83] W.-D. Moeller, "Operating Experience with superconducting Cavities at the TESLA Test Facility." These Proceedings.
- [84]. K. C. D. Chan, H. Safa, C. Pagani, and M. Mizumoto, "Review of superconducting RF Technology for High-Power Proton Linacs", 9th Workshop on RF Superconductivity, p. 465.
- [85] H. Safa, "Superconducting Proton Linac for Waste Transmutation," 9th Workshop on RF Superconductivity, p. 357.
- [86] N. Ouchi, J. Kusano, N. Akaoka, S. Takeuchi, B. Fechner, K. Hasegawa, M. Mizumoto, H. Inoue, E. Kako, S. Noguchi, M. Ono, K. Saito, K. Mukugi, Y. Honda, "Design and Development Work for a Superconducting Proton Linac at JAERI" 8th Workshop on RF Superconductivity, p. 22.
- [87] Y. Yamazaki, "The present status of the JAERI/KEK Joint Project for high-intensity proton accelerators", PAC2001, Chicago, IL, June 2001
- [88] M. Matsuoka, K. Sennyu, H. Hattori, K. Okubo, N. Ouchi, H. Ao, N. Akaoka, O. Takeda, H. Yoshikawa, S. Noguchi, K. Saito and E. Kako, "RF Power Coupler Development for Prototype Cryomodule at JAERI", These Proceedings.
- [89] N. Akaoka, E. Chishiro, K. Hasegawa, M. Mizumoto, J. Kusano, N. Ouchi H. Inoue, E. Kako, S. Noguchi, M. Ono, K. Saito, T. Shishido, K. Mukugi, C. Tsukishima, O. Takeda, M. Matsuoka, "Superconducting Cavity Development for High-Intensity Proton Linac in JAERI", 9th Workshop on RF Superconductivity, p. 450.
- [90] K. M. Wilson, I. E. Campisi, E. F. Daly, G. K. Davis, M. Drury, J. E. Henry, P. Kneisel, G. Myneni, T. Powers, W. J. Schneider, M. Stirbet, Y. Kang, K. Cummings, T. Hardek, "The prototype fundamental power coupler for the Spallation Neutron Source superconducting cavities: design and initial test results", These Proceedings.
- [91] M. Stirbet, Private communication: the SNS prototype couplers have exceeded 2 MW peak power.