

# DESIGN AND FABRICATION OF SUPERCONDUCTING CAVITIES FOR INDUSTRIALIZATION

K. Sennyu<sup>#</sup>, H. Hara, M. Matsuoka  
Mitsubishi Heavy Industries, Ltd, Kobe, Hyogo, 652-8585, Japan

## Abstract

MHI has supplied various types of superconducting cavities mainly to KEK in Japan since TRISTAN project started at 1977. We have a lot of experience in the development of superconducting cavities for Japanese projects. And we have the technology to design and fabricate the superconducting cavities. We can present some ideas to improve the quality, cost, and delivery time of the superconducting cavities based on our experience. We designed and fabricated four STF-Baseline superconducting cavities with frequency tuners, helium jackets, according to KEK specifications. To decrease a cavity deformation occurring due to Lorenz force, rigid jacket systems including tuner were designed. By fabricating four cavities, some problems and improvements in the next step are cleared. Some ideas to reduce the fabrication cost are proposed in this paper.

## INTRODUCTION

STF (Superconducting RF Test Facility) is under construction at KEK. MHI designed and fabricated four superconducting RF cavities for STF. After the vertical test at KEK, the cavities were assembled inside the titanium jacket with bellows in our factory. Presently, we are designing two more superconducting RF cavities for STF phase 1.5. Some improvements for STF1.5 from STF1.0 and some ideas for ILC are described in this paper.

## THE HISTORY OF THE SUPERCONDUCTING CAVITIES AT MHI

We have a lot of experience in designing and fabricating superconducting cavities in Japanese various projects as shown in table 1.

Table 1: MHI's history of the superconducting cavities.

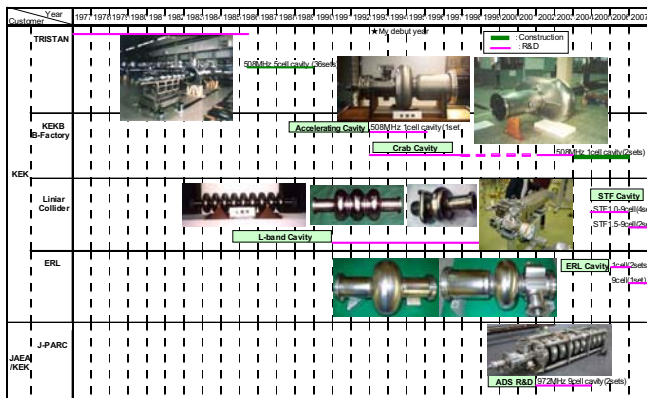

## DESIGN OF STF BASELINE CAVITY

A STF baseline cavity system consists of a 9-cell niobium cavity, a titanium jacket, a frequency tuner and a magnetic shield. The main features and dimension of the STF baseline cavity are shown in fig.1.

### Specification of STF Baseline cavity

The main specifications of STF baseline cavity are shown in table 2. To decrease Lorentz detuning, rigid jacket systems including a tuner were designed. The jacket stiffness was designed to be about 25 times as large as the cavity stiffness. [1]

To make a jacket system rigid, some modifications of TESLA cavity are summarised as follows: (shown in fig.2)

- Thick titanium baseplates.
- Thick beam tube by machining from the ingot.
- Thick bellows flange.
- Thick jacket body.
- Rigid frequency tuner system.

As a result of the improved jacket system, the stiffness is calculated as 72kN/mm. Therefore, the Lorenz detuning is calculated as -550Hz in operation at 31.5 MV/m.

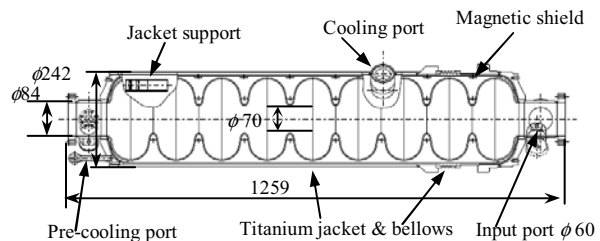

Figure 1: The STF baseline cavity with jacket.

Table 2: Specification and design value of the STF baseline cavity.

-	KEK Specification	Designed value or calculated
Nb sheet thickness	Center-cell:2.8mm End-cell:3.5mm	-
Iris, equator thickness	-	2.5mm
Cavity stiffness	3,500N/mm	3,000N/mm
Jacket Stiffness with tuner	90 kN/mm	72 kN/mm
Lorentz Detuning at 31.5 MV/m	- 600 Hz	~ 550 Hz
Magnetic shield	Inside the jacket	-

<sup>#</sup>katsuya\_sennyu@mhi.co.jp

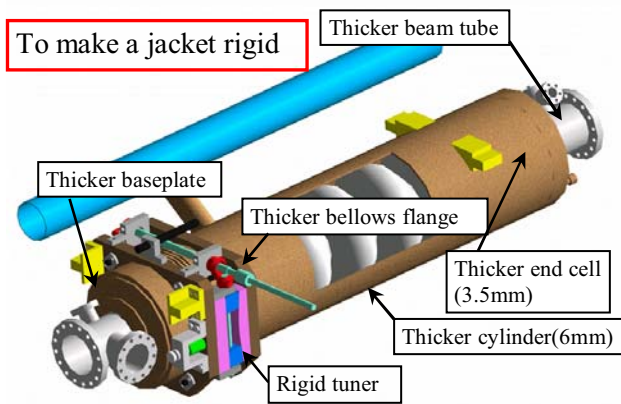

Figure 2: Design of the STF baseline cavity to conform to a rigid jacket.

### Frequency Tuner

A slide-jack tuner system (see Fig.3) based on the concept from KEK [2] was developed for the STF-Baseline cavities. A stepping motor outside of the vacuum vessel drives the tuner shaft. All parts are designed in oil-free condition because of the low temperature (2K) operation.



Figure 3: The frequency tuner with test stand.

## FABRICATION OF STF BASELINE CAVITY

### Dressing of the Helium Jacket

After the vertical tests [3], the four cavities were transported to our factory filled with Argon gas from KEK inside of the cavities. After covering the magnetic shield outside the cavities, the titanium jackets with bellows were dressed by TIG welding, as shown in Fig.4. Four shafts with ball bearings restrict the bellows.

After dressing the helium jacket, the four cavities were transported to KEK. And one of the four cavities was mounted frequency tuner and input coupler, as shown in Fig.5.



Figure 4: Before and after welding of a helium jacket. A magnetic shield (center left) was placed inside a helium jacket.



Figure 5: The STF cavity with jacket, tuner and input coupler at KEK.

### Some problems at fabrication of STF cavity

There were some problems, as follows, of the fabrication of STF cavity.

- Design: Some parts (HOM coupler, beam tube) needed brushing up by hand in order to smooth the shape conversion.
- EBW: Quality of inner welding beads was not smooth so that some of the beads remained after the barrel polishing.
- Environment: A cleaner area in assembling the cavity before EBW is needed. Contamination during assembly might cause the heating spot at the equator.
- Cleanness: The cavity parts were not frequently treated by chemical polish. The contamination might cause a heating spot at the welding beads.

### IMPROVEMENT FOR STF1.5 FROM STF1.0 AT KEK

We will fabricate two more superconducting cavities for STF phase 1.5. Now we are designing details according to KEK specifications. The main improvements for STF1.5 from STF1.0 are described below.

- HOM coupler design [4]: The angle of the pick-up antenna and loop antenna of HOM coupler is changed due to decrease  $Q_{ext}$  of HOM as shown in Fig.6. The design of the adapted angle is calculated by KEK.
- The beam tube design: The diameter is changed 84mm to 80mm by measurement of  $Q_{in}$  at KEK.
- Flange design: The flange thickness is thinner and the number of the bolt holes is reduced due to cost reduction and easy assembling.
- Cavity shape [5]: Cavity shape is changed by changing the target frequency.
- Welding condition: The thickness of the equator is changed from 2.5mm to 2.0mm due to the smooth welding beads. And the cleaning of the edge by CP is processed at all times before EBW.

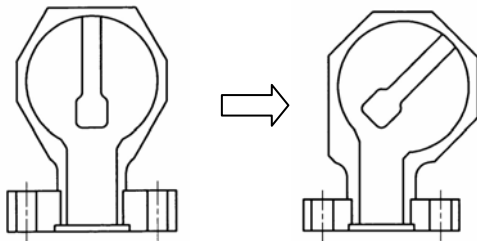

Figure 6: Cross section of the HOM coupler of STF1.0 (left) and STF 1.5 (right).

### SOME IDEAS TO REDUCE COST FOR INDUSTRIALIZATION

We have to consider Quality, Cost and Delivery time in mass production. We expect the ILC organization to discuss QCD from the point of view as described below,

- **Quality:** What the ILC organization will make us guarantee, in terms of performance ( $E_{acc}$ ,  $Q$ )?
- **Cost:** ILC organization has to reduce the cost not only for production but also for surface treatment and vertical test.
- **Delivery time:** ILC organization should realize the realistic delivery time of the material (Nb, Ti), capacity of the production facility and the treatment and test facility.

We have to consider improving QCD to realize ILC. Now we will propose some ideas to reduce the cost of the cavity production. All these ideas need to be studied concerning quality and delivery time by R&D.

### Material cost

We should try to reduce expensive materials such as niobium (Nb) and niobium-titanium (NbTi) as described below.

- Cell: We need to study reducing the thickness from the viewpoint of the frequency shifts by Lorentz detuning.
- Magnetic shield: We need to study reducing the thickness from the viewpoint of the Q drop by penetrating a magnetic field to cavity.
- Jacket and baseplate: We need to study reducing the thickness from the viewpoint of the frequency shifts by Lorentz detuning and tuner response.
- Beam tube: We need to study lowering required RRR value of Nb from the viewpoint of the performance in the vertical test.
- Flange: We need to study changing the material NbTi to Ti or Nb alloys from the viewpoint of the vertical test and leak tight. A cavity does not need a 1400 degree treatment.

### Machining and forming cost

We should try to reduce the machining and forming cost as described below for example.

- HOM coupler: We need to study simplifying HOM coupler design from the viewpoint of the character of HOM  $Q_{ex}$  as shown in Fig. 7. We propose to fabricate the stub the same thickness as antenna.
- Beam tube: We need to develop forming of the beam tube more than 4mm thick in place of machining.
- Baseplate: We need to develop forming of the baseplate more than 20mm thick in place of machining.

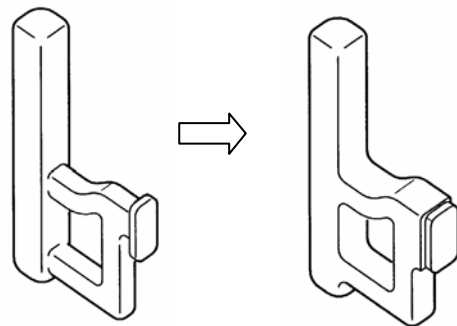

Figure 7: The inner conductor of the HOM coupler for STF1.0 (left) and ILC proposal (right).

### Welding cost

We should try to reduce the welding cost as described below for example.

- **Flange:** We need to study joining flanges and beam tubes by brazing not welding from the viewpoint of the mechanical properties and the cavity performance.
- **Stiffener:** We need to study joining stiffeners and half-cells by brazing not welding from the viewpoint of the mechanical properties and the cavity performance as shown in fig.8. This procedure can decrease not only the cost but also the cavity deformation.
- **Iris:** We need to study decreasing the iris welding by new forming method from the viewpoint of the cavity performance as shown in fig.9. This method increases the forming ratio and material cost.

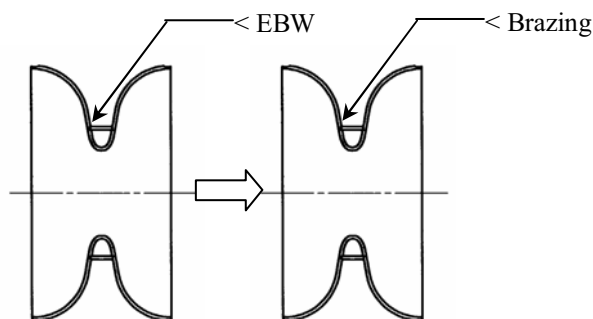

Figure 8: The procedure for joining the stiffener and half-cell for STF1.0 (left) and ILC proposal (right).

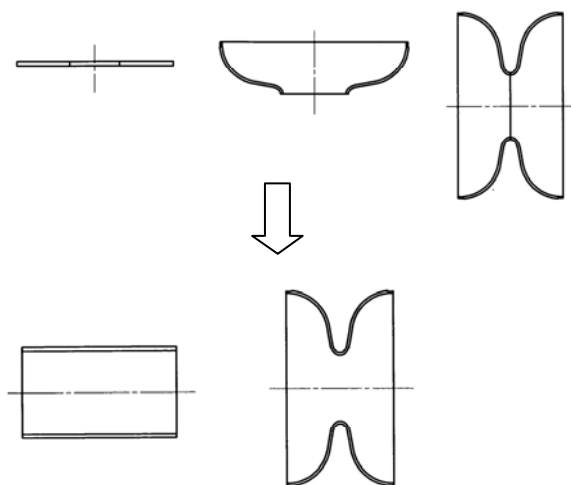

Figure 9: The new forming method (bottom) to decrease the iris welding compared to the traditional method (top).

### CONCLUSION

- We have a lot of experience in the development of superconducting cavities for various Japanese projects. We have some ideas to improve the quality, cost and delivery time of the superconducting cavities based on our experience.
- We designed and fabricated four STF baseline cavities. And all cavities have been carried out the vertical test at KEK. We recognized what we should do for the next step by fabricating four STF baseline cavities.
- Some improvements of STF1.5 from STF1.0 were shown.
- Some ideas to reduce the cost for ILC were proposed. These ideas need some R&D.
- We have more ideas to improve quality, cost and delivery time for ILC. We will present them at the next opportunity.

### ACKNOWLEDGEMENT

Special thanks to S. Noguchi, E. Kako, T. Shishido, K. Watanabe at KEK for this paper.

### REFERENCES

- [1] K. Sennyu, et al., "Design and Fabrication of Superconducting Cavities for STF", PAC'07, Albuquerque, NM, USA, (2007)
- [2] S. Noguchi, et al., "Review of New Tuner Design", SRF2007, Beijing, China, (2007) WE303 in this proceedings
- [3] E. Kako, et al., "Vertical Test Results STF Baseline 9-cell Cavities at KEK", SRF2007, Beijing, China, (2007) WEP10 in this proceedings
- [4] K. Watanabe, et al., "Higher Order Mode Study of Superconducting Cavity for ILC Baseline", EPAC'06, Edinburgh, Scotland, (2006) p747-749
- [5] E. Kako, "Frequency & Length Change in each steps on the four STF Baseline Cavities", STF Baseline Meeting, (2007, April 20<sup>th</sup>)