

# HOM COUPLERS AND RF ANTENNAS FOR HL-LHC CRAB CAVITIES: DEVELOPMENTS FOR MANUFACTURING

S. Barrière\*, S. Atieh, B. Bulat<sup>1</sup>, R. Calaga, S. Calvo, O. Capatina, T. Demazière<sup>1</sup>, G. Favre, A. Gallifa Terricabras, M. Garlaschè, J.-M. Geisser, L. Prever-Loiri, J. Mitchell, E. Montesinos, F. Motschmann, P. Naisson, R. Ninet, L. Renaglia<sup>2</sup>, K. Scibor and N. Villanti  
CERN, Geneva, Switzerland

<sup>1</sup>also at Foselev Suisse SA, Vernier, Switzerland

<sup>2</sup>also at Kraftanlagen Assystem Consortium, Geneva, Switzerland

## Abstract

Superconducting RF crab cavities are being manufactured as part of the High-Luminosity LHC project at CERN. Amongst its related ancillaries, radiofrequency HOM (High Order Modes) couplers and field antennas are essential for reaching nominal performance during operation with high energy beams, as they monitor and control the electromagnetic fields in the cavities. Several concepts of such equipment have been engineered and manufactured, for both design validation and RF performance assessment.

The following paper highlights manufacturing process definition, its challenges and the assembly strategies focusing on the ongoing RFD prototypes for the SPS beam tests. Specific tooling development and test campaigns are also described.

## INTRODUCTION

In the scope of the HL-LHC project [1], compact crab cavities will be installed in the LHC during the Long Shutdown 3. The purpose of such equipment is to increase the integrated luminosity of the LHC machine, through a reduction of the beam crossing angles at the interaction points [2].

Two cavity types have been developed and prototyped [3] at CERN main workshop for SPS beam tests, the Double Quarter Wave (DQW) cavities for ATLAS and the Radiofrequency Dipole (RFD) cavities for CMS. Each version comes with bespoke RF devices: the so-called High Order Modes (HOM) couplers and field antennas, designed to sustain the required high-power electromagnetic fields in the cavities. Whereas the HOM couplers (or suppressors) are essential to damp the detrimental resonance modes generated by the passage of the LHC beams, the field antenna is an acquisition device which allows precise control and feedback on the RF field quality during operation.

Specific variants of such equipment have been engineered [4] for the DQW and RFD cavities, as shown in Fig. 1. Each system features 3D shapes with demanding manufacturing and assembly tolerances. SRF requirements impose tight precision on the final assemblies, in the order of a few tenths of millimetres (up to  $\pm 0.2$  mm). Fabrication

is also rendered more complex by the intricate shape of the couplers, which calls for an elaborate assembly sequence.

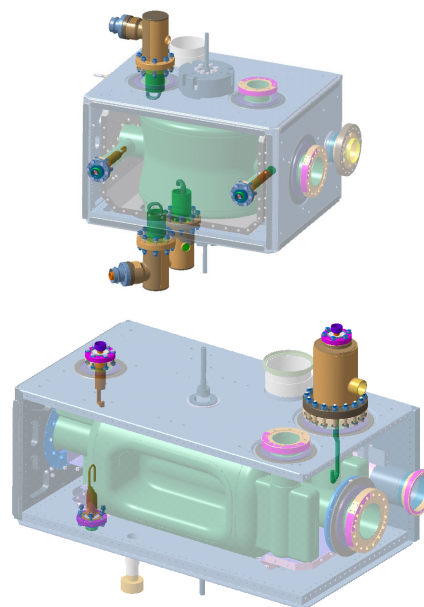

Figure 1: 3D views of the DQW (top) and RFD (bottom) dressed crab cavities with RF couplers and antennas.

Such a manufacturing endeavour requires a well-defined strategy for definition of sub-assemblies' cut-out, implementation of advanced fabrication and joining techniques, down to an extended development campaign and quality assurance. All these aspects are presented in this paper.

## EXAMPLE OF MANUFACTURING STRATEGY AND CUT-OUT

The complexity of the HOM couplers' shape imposes to find a good compromise between attainable geometrical tolerances, ease of manufacturing and material cost. To answer this problematic, the following strategy, shown in Fig. 2, was employed in the case of the RFD H-HOM coupler:

- Step 1: RRR300 niobium tubes are brazed [5] to 1.4429 stainless steel (316LN) flanges, while maintaining both niobium and stainless-steel components in a rough shape. After brazing, these subassemblies are machined to their final shape (with anticipation of welding shrinkage).

\* simon.barriere@cern.ch

- Step 2: the top asymmetric brazed assembly (called “top cover”) is welded to the bottom niobium pipe. Performing such an EB (Electron-Beam) weld at this stage allows better accessibility for non-destructive inspection techniques.
- Step 3: after complete machining of the bulk parts of the RF niobium antennas, the latter are EB welded to the H-HOM tube. A specifically designed tooling is exploited to guarantee and maintain the correct geometrical alignment of parts during welding.
- Step 4: the last step consists in EB and TIG (Tungsten Inert Gaz) welding of the outer stainless-steel jacket to the DN100 flange.

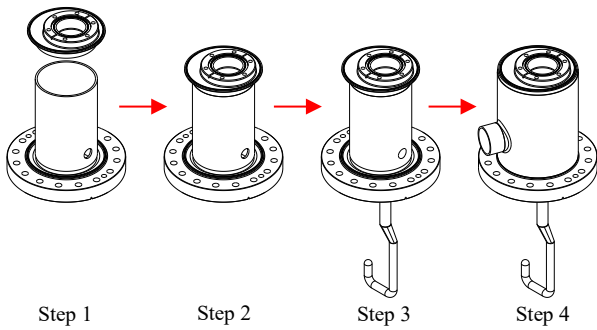

Figure 2: H-HOM assembly sequence.

## HIGHLIGHT OF FABRICATION DEVELOPMENTS

The following section examines the main technical challenges tackled during production, with particular focus on the HOM couplers and field antenna for the RFD SPS prototype cryomodule [6].

### Machining

Depending on the desired type of RF coupling, the couplers’ tips geometry can vary but is, in most cases, either hook-shaped or mushroom-shaped. Due to RF-sensitivity to the surface quality of such sub-components, multi-axis high-precision machining is the fabrication technique of choice, both in case of niobium and copper hooks.

The hooks for the RFD V-HOM coupler and field antenna are machined from bulk OFE (Oxygen-Free Electronics) C10100 copper rods, whereas ultrapure RRR300 niobium thick plates are used for the H-HOM coupler. All versions require a multi-step machining process, which starts with NNS (Near Net Shape) blanks wire-cut with the EDM technique (Electrical Discharge Machining). The cylindrical and long-overhanging shape of the hook’s body does not allow finishing with a single clamping stage. Therefore, specific stainless-steel fixtures have been manufactured to allow precise two-sides clamping of this bulk piece for final machining operations (see Fig. 3).

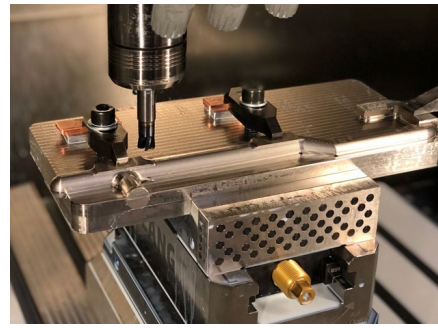

Figure 3: Custom machining fixture for finishing operation of a H-HOM niobium hook.

In the case of the RFD field antenna, CAM (Computer-Aided Manufacturing) simulations and the experience obtained throughout production of the DQW HOM couplers have allowed a clear definition of the best machining strategy (see Fig. 4), in this case called “incremental machining”, aiming at minimum deformations on the fragile hook’s tip. This method consists in a combination of stress-reduced clamping and multi-step machining with intermediate CMM (Coordinate-Measurement Machine) measurements. For all kind of hooks, the achieved shape accuracy after final machining is  $\pm 5 \mu\text{m}$  on the critical zones, and  $\pm 70 \mu\text{m}$  on the total shape.



Figure 4: 6-steps incremental machining to obtain the copper hook of the RFD field antenna.

Several cutting trials have been performed to compare performance of different cutting fluids. The retained technique is the MQL (Minimum Quantity Lubrication) with the straight mineral-based oil Vascomill™.



Figure 5: Comparison of surface finishing with two different lubricants: Vascomill™ (top) and Blasocut™ (bottom).

With regards to the CERN standard cutting oil (Blasocut™), the achieved surface roughness is enhanced by a factor 4 [7]. As shown in Fig. 5, the aspect of the piece is also brighter, which indicates a smoother surface finishing. The parts obtained have been measured both in terms of

surface rugosity ( $R_a < 0.4 \mu\text{m}$  achieved) and dimensions. Dedicated quality reports have been prepared and released to ensure traceability during the whole fabrication cycle.

Finally, as a standard process for SRF niobium devices, a surface treatment called BCP (Buffer Chemical Polishing) is applied. In the case of the RFD H-HOM coupler, four BCP steps have been performed after machining, totalling  $60 \mu\text{m}$  removal per surface. This etching process allows removal of contamination (oils, burrs, tool fragments) that could be incusted in the parts during machining, which could degrade SRF performance of the couplers.

### Joining Techniques

As seen previously, HOM couplers are very critical RF components for the good operation of crab cavities, while the quality of their performance is tightly linked to the quality of the obtained geometrical shape. Niobium HOM couplers are actively helium-cooled components; the leak tightness of their joints must thus be ensured. Therefore, an extensive testing campaign has been carried out to fulfil RF welding requirements, together with leak tightness, surface integrity and safety requirements.

**Electron Beam Welding** The most challenging aspect of EB welding on RF components is the presence of specific constraints, more stringent than what requested in normative such as ISO 13919-1 level B. Such additional requirements can be resumed as follows:

- No spatter.
- Smooth weld surface (on active RF surface).
- No undercuts or root concavity (on active RF surface).
- Contained excess of penetration (max 0.2 mm).

These requirements often mean that, for a given thickness, a specific welding procedure must be employed, using an unfocused beam and a much higher heat input than a typical focused parameter.

A good deposition energy balance must be found, too much energy can cause a collapse of the weld pool, while not enough energy can result in a lack of fusion, or incomplete melting of the joints. The balance can be difficult to find as a small variation of beam current can have a harmful effect. For niobium, a variation of beam current of more than  $\pm 3\%$  at 45 mA as nominal beam current and 100 kV of accelerating voltage is very likely to cause defects during welding. The geometry of the parts is also important, and the welding test samples must match as close as possible the parts to be welded in terms of thickness, diameter, and mass. As an example, a successful parameter for welding a 2.45 mm thick sheet, can lead to failure if used for welding of a 2.6 mm part.

Following the testing campaign, an optimal set of parameters was found for the different welding configurations and tested on representative samples.

Figure 6 shows a metallographic cross section of the welding parameter used for the weld between the two brazed niobium jackets of the RFD H-HOM. It can be seen how the chosen parameter yields sound compacity.

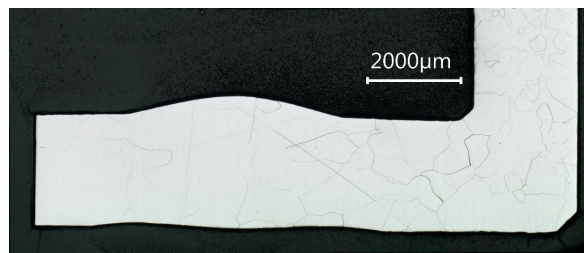

Figure 6: Macrograph of a test sample simulating the weld between the niobium brazed top cover and the niobium tube (W050).

The parameter was successfully applied to the final components of the RFD H-HOM coupler (see Figs. 7 and. 8).

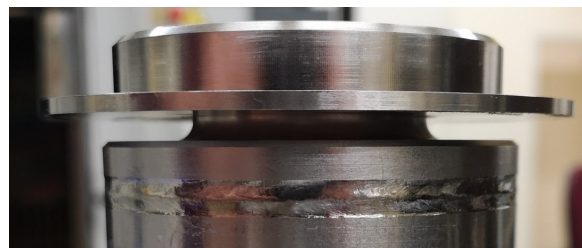

Figure 7: Face of the Nb-Nb weld between capot and tube.

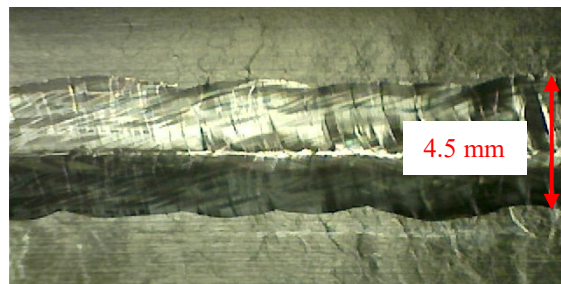

Figure 8: Weld root on the RF surface. Width of the root is 4.5 mm.

The weld between the niobium antennas and the tube proved to be amongst the most challenging welds. The first joint design (left on Fig. 9) did not allow to comply with acceptance criteria due to the difference of thickness between the 2.5 mm tube and the  $\phi 10$  mm bulk of the antenna. As a result, a shoulder with a 2 mm radius was added (right on Fig. 9), both to bring the joint configuration closer to a regular butt weld, and to have a well-defined radius on the RF-side. However, machining becomes more complex as this new radius imposes a 5-axis machining process with a reduced access.

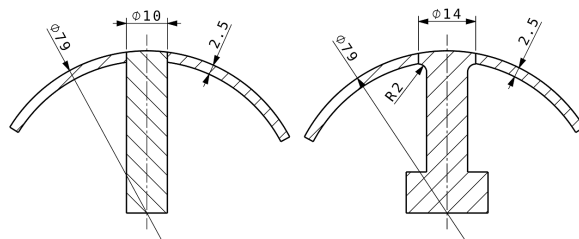

Figure 9: Cut views of the original joint design for hooks' weld (left) and new design (right).



Content from this work may be used under the terms of the CC BY 4.0 licence (© 2022). Any distribution of this work must maintain attribution to the author(s), title of the work, publisher, and DOI

The optimal set of parameters found for the niobium hooks' joint can be seen in the test sample in Fig. 10.



Figure 10: Macrography of welding test sample used to qualify the Nb-Nb hooks' welds.

The chosen parameter produced a very smooth and flat weld root around the entire circumference of the joint (see Fig. 11).

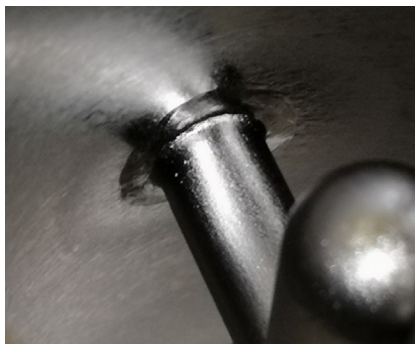

Figure 11: Weld root obtained with the new Nb-Nb joint configuration.

**Tooling Design** Custom fixtures have a primary role in EB welding. The weld quality in terms of geometrical accuracy and welding acceptance criteria directly depends on the quality of the tooling design and fabrication, see Fig. 12.

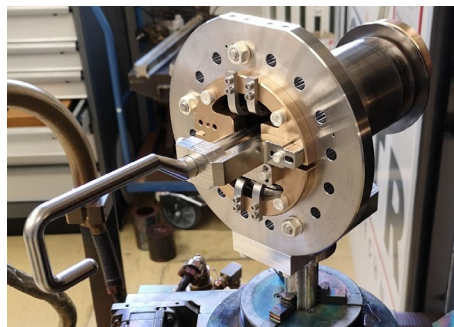
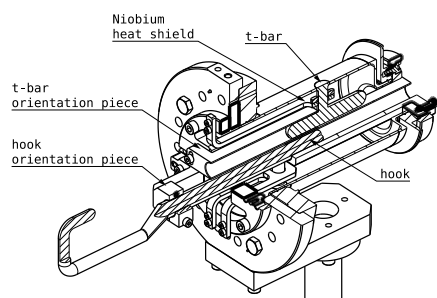

Figure 12: Tooling 2D-drawing (top) and setup ready for hook and T-bar welding (bottom).

Such a tooling must guarantee the following functionalities:

- Align parts to be welded as precisely as possible with respect to the reference system.
- Assembly must be as lean as possible.
- Precise rotation around circumference to be welded.
- Protect stainless steel and other niobium parts from accidental beam impact/projections.
- All tooling parts must be removable after welding.
- All material for tool components must be compliant with RF requirements (i.e., no contact with aluminium), especially while welding niobium.

**Vacuum Brazing** Niobium to 1.4429 stainless-steel brazing using OFE copper as filler metal is a well mastered process at CERN [8], through which joints showing a brazed area  $\geq 95\%$  can be produced with high repeatability (see Fig. 13).

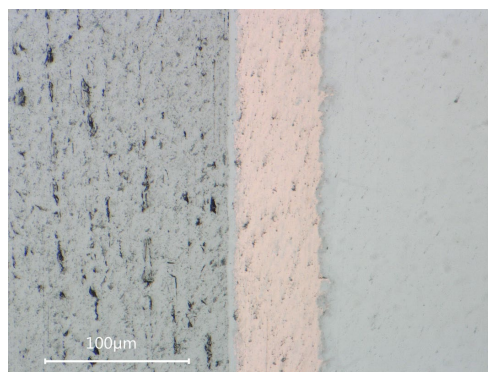

Figure 13: Vacuum brazing joint between a niobium tube (left), 1.4429 stainless steel flange (right) using copper as filler metal (centre).

Ceramic feedthroughs entailed in the RFD HOM couplers and field antenna require the assembly of a central copper conductor to an outer titanium flange, with an intermediate alumina insulation disc. This complex assembly of dissimilar materials is a challenging step in the manufacturing process of brazed RF feedthroughs. The implementation of a rotating flange design has allowed to reduce the volume of brazed titanium. This has led to the reduction of stresses applied during the tightening of the flange and the thermal shocks (both in operation and in the test campaign), thus greatly reducing the onset of cracks in the alumina ring. Developments on brazing process optimization are still ongoing.

### Final Metrology after Assembly

Final geometrical precision of coupler's assembly must be checked to ensure a good RF performance. Thanks to the accurate machining of parts, efficient tooling design and adequate assembly procedures, a good accuracy was reached for H-HOM assemblies (see Fig. 14) as well as for the other ancillaries.

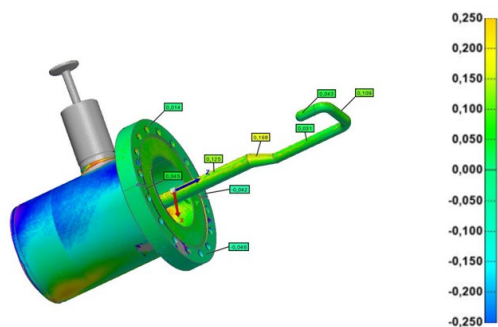

Figure 14: 3D metrology of a complete H-HOM assembly using a CREAFORM laser scanner, maximum deviation from nominal shape according to reference system on the hook is 0.17 mm (target 0.2 mm).

## RF VALIDATION

To assess the couplers' performance at the operational temperature of 2 K, RF measurements were performed and compared to the simulated response to confirm that the manufactured couplers operated as intended. An example of this measurement is shown in Fig. 15, measuring broadband transmission between the RFD H-HOM and V-HOM couplers.

These tests were carried out during performance assessment [9] of the dressed RFD crab cavity prototypes at CERN's SRF test facility. The frequency and quality factor of each HOM was also measured. To ensure that the HOM power is within the operational limitations, frequency and quality factor thresholds were pre-defined for the HOM at ~750 MHz, as this mode has a high longitudinal R/Q and is close in frequency to the 19<sup>th</sup> bunch spacing harmonic of an HL-LHC type beam. The measured frequency and quality factor of this mode was within tolerance, showing that the HOM couplers provided the correct amount of damping at this frequency.

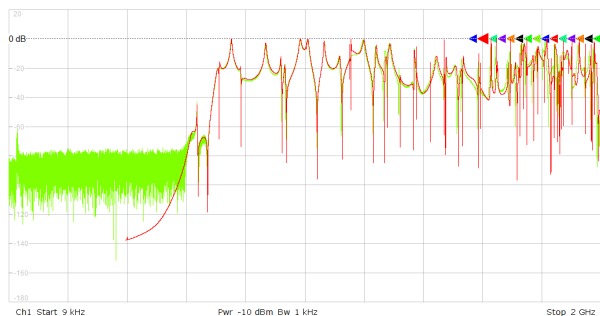

Figure 15: Simulated (red) and measured (green) response spectrum in dB, where port 1 is connected to the H-HOMC and port 2 to the V-HOMC on the RFD cavity.

## CONCLUSION AND OUTLOOK

A full set of RF HOM couplers and field antennas was successfully manufactured at CERN main workshop, in compliance with the tight specification imposed by SRF requirements. All procedures and parameters have been validated through various inspections and final RF measurements. Related inspection and quality strategy has been thoroughly followed in line with the HL-LHC project standards.

In addition to having allowed production of functional prototypes, the test campaigns and manufacturing strategies developed have been thought to also boost efficiency during the upcoming series production phase.

## REFERENCES

- [1] G. Apollinari, O. Brüning and L. Rossi, "High Luminosity LHC Project Description", CERN-ACC-2014-0321, Geneva, 2014. <http://cds.cern.ch/record/1974419>. ss
- [2] R. Calaga, "Crab Cavities for the High-luminosity LHC", in *Proc. 18th Int. Conf. RF Superconductivity (SRF'17)*, Lanzhou, China, Jul. 2017, pp. 695-699. doi:10.18429/JACoW-SRF2017-THXA03
- [3] M. Garlasché, "Advanced Manufacturing Techniques for the Fabrication of HL-LHC Crab Cavities at CERN", in *Proc. 18th Int. Conf. RF Superconductivity (SRF'17)*, Lanzhou, China, Jul. 2017, pp. 409-414. doi:10.18429/JACoW-SRF2017-TUPB013
- [4] C. Zanoni *et al.*, "Engineering Design and Prototype Fabrication of HOM Couplers for HL-LHC Crab Cavities", in *Proc. 17th Int. Conf. RF Superconductivity (SRF'15)*, Whistler, Canada, Sep. 2015, paper THPB069, pp. 1279-1283. <https://jacow.org/SRF2015/papers/thpb070.pdf>
- [5] J.P. Bacher *et al.*, "Brazing of niobium to stainless steel for UHV applications in superconducting cavities", CERN Preprint CERN/EF/RF 87-7, 1987.
- [6] T. Capelli *et al.*, "Design of Crab Cavity Cryomodule for HL-LHC", in *Proc. 19th Int. Conf. RF Superconductivity (SRF'19)*, Dresden, Germany, Jun.-Jul. 2019, pp. 320-325. doi:10.18429/JACoW-SRF2019-MOP099
- [7] P. Naisson *et al.*, "State of the Art of Niobium Machining for SRF Applications", in *Proc. 19th Int. Conf. RF Superconductivity (SRF'19)*, Dresden, Germany, Jun.-Jul. 2019, pp. 210-213. doi:10.18429/JACoW-SRF2019-MOP061
- [8] N. Valverde Alonso *et al.*, "Electron Beam Welding and Vacuum Brazing Characterization for SRF Cavities", in *Proc. 27th Linear Accelerator Conf. (LINAC'14)*, Geneva, Switzerland, Aug.-Sep. 2014, paper THPP039, pp. 932-934. <http://jacow.org/LINAC2014/papers/thpp039.pdf>
- [9] N. Valverde Alonso *et al.*, "RF dipole crab cavity R&D for HL-LHC", presented at *20th Int. Conf. on RF Superconductivity (SRF'21)*, virtual conference, June 2021, paper WEOCAV03, this conference.