

THE 1.5 GHz COUPLER FOR VSR DEMO: FINAL DESIGN STUDIES, FABRICATION STATUS AND INITIAL TESTING PLANS

E. Sharples-Milne*, V. Dürr, J. Knobloch¹, S. Schendler, A.V. Velez², N.W. Wunderer
 Helmholtz Zentrum Berlin, Berlin, Germany

¹ also at Universität Siegen, Faculty of Physics, Siegen, Germany

² also at Technische Universität Dortmund, Faculty of Physics, Dortmund, Germany

Abstract

The variable pulse length storage ring demo (VSR DEMO) is a research and development project at the Helmholtz Zentrum Berlin (HZB) to develop and validate a 1.5 GHz SRF system capable of accelerating high CW currents (up to 300 mA) at high accelerating fields (20 MV/m) for application in electron storage rings. Such a system can be employed to tailor the bunch length in synchrotron light source such as BESSY II. VSR DEMO requires a module equipped with two 1.5 GHz 4-cell SRF cavities and all ancillary components required for accelerator operations. This includes one 1.5 GHz fundamental power coupler (FPC) per cavity, designed to handle 16 kW peak and 1.5 kW average power. The final design studies, fabrication status and initial testing plans for these FPCs will be presented.

VSR DEMO

In order for VSR DEMO to reach its goal of validating SRF technology to achieve high current (300 mA) - high gradient (20 MV/m) – CW operation and enable future high current CW projects, a test module needs to be developed. This module comprises of two complex SRF cavities, two FPCs and ancillary components such as the collimated shielded bellows, the full module can be seen in Fig. 1. Full details of the current status of the cold string can be found in [1] and of the module in [2]. This module will be commissioned at peak power in the bERLinPro bunker at HZB, with a beam test in the bERLinPro accelerator considered as a final validation step.

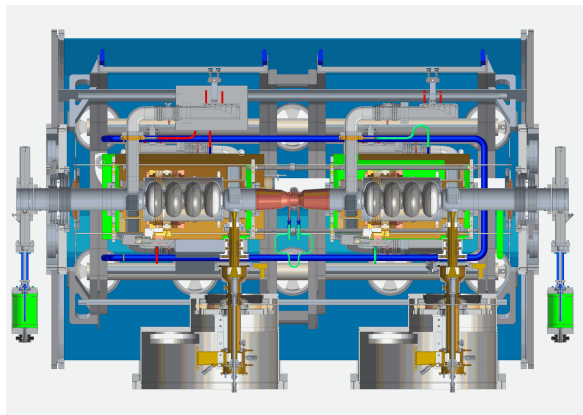

Figure 1: The VSR DEMO module showing the cold string components.

* emmy.sharples@helmholtz-berlin.de

COUPLER DESIGN AND RF RESPONSE

VSR demo requires couplers to provide 16 kW peak and 1.5 kW average power for CW operation at 1.5 GHz. The design has been extensively developed and the finalised RF design gives the results shown in Fig. 2. This S_{11} plot of the reflected power shows that the coupler gives a strong RF response within the VSR operating range. To ensure good performance VSR requires an RF response with S_{11} reaching at least -30 dB, equivalent to 0.1% reflected power. This design exceeds this requirement, reaching -50 dB at the central frequency and remaining well under -30 dB within the operating range.

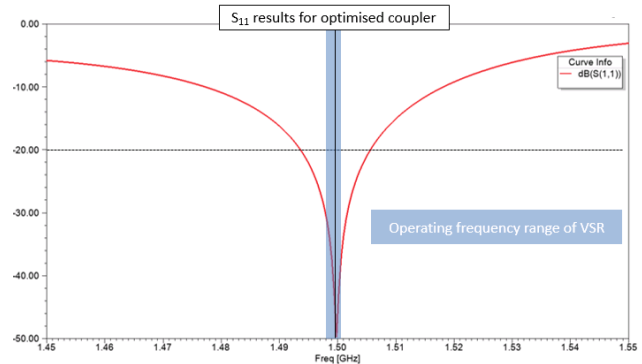

Figure 2: The S_{11} plot of the final coupler with the operational range for VSR superimposed over.

Figure 3 shows the final coupler design, which has undergone significant development to ensure the best possible performance, full details including the results of multipacting studies can be found in [3] and [4]. The design is based the Cornell coupler [5] and [6] scaled for the VSR DEMO frequency range. It is a coaxial style coupler with two cylindrical ceramic windows, one warm, one cold, and two sets of bellows for an adjustable coupling range. The main changes from this base design to meet the VSR DEMO requirements will be presented here.

The VSR DEMO cavity is highly complex due to the need to damp the higher order modes (HOMs) [7]. This is done using 5 waveguides which come off the cavity end groups and end in HOM loads. Since the FPC is also located on the cavity end group it is essential to stop or mitigate HOMs propagating up the coupler port. This could result in a standing wave in the coupler cold part, leading to damage of the cold window and performance degradation. By reducing the cold coaxial dimension, the HOMs are more likely to

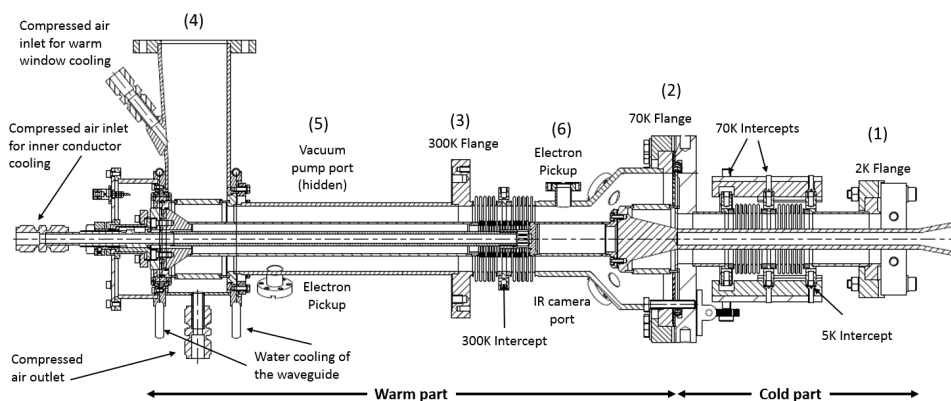

Figure 3: The assembly drawing of the full coupler showing intercepts, ports and the cold and warm parts.

propagate up the surrounding waveguides than the coupler port.

The warm coaxial part of the coupler is larger in both radius and length than a scaled version of the Cornell design. The warm coax has a larger radius to ease coupler assembly with more space and give more space to the compressed air cooling of the warm inner conductor. The length of the warm part of the coupler was increased to ensure that the coupler came far enough out of the module to fit the thermal and magnetic shields and enable connection the RF system. Even with this increased length the coupler does not fully protrude out of the module, but any further increase would cause stresses in the system due to the horizontal mounting of the coupler. The solution was the addition of recessed coupler ports in the module referred to as the ‘Nudeltopf’, as seen in Fig. 1.

The external Q factor Q_{ext} is a measure of the coupling, the initial requirements for VSR were a range of Q_{ext} from 6×10^6 to 6×10^7 . The design of the coupler tip and the amount it penetrates into the cavity dictate the level of coupling. Due to the coupling level required, the horizontal mounting of the coupler and system constraints, the coupler tip design has developed significantly from the ‘Pringle’ style Cornell coupler tip. This development resulted in a hollow conical tip, full details of this development and the effects on the coupling factor can be found in [3]. However, even with this optimised design the initial order of magnitude Q_{ext} was not reachable, due to the bellows limiting the range of tip movement to ± 4 mm.

Since the ideal Q_{ext} range is not reachable a new optimised range should be found and the length of the coupler tip fixed to ensure this is achievable with the ± 4 mm range of movement. The aim is to provide as much tuning overhead as possible while maintaining an acceptable average power level. Figure 4 shows the analysis results of the forward power, the detuning overhead and the external Q. The optimal Q_{ext} range is indicated by the green box, it shows a range of movement from -2 to 6 mm, which is equivalent to shifting the neutral position of the tip 2 mm further into the

cavity. The resultant 2 mm longer tip gives an optimal Q_{ext} range is from 9.1×10^6 to 3.9×10^7 .

THE COUPLER AS PART OF THE COLD STRING AND MODULE

Often it is easier to consider the coupler as an independent component, however the cavity and the coupler are strongly linked and changes to the cavity especially in the region of the coupler port affect the coupler. This has already been discussed in terms of HOMs, but this is not the only way the cavity effects the coupler. Moreover, the coupler design can also be affected by module design. In this section the design studies performed as a direct result of these interactions with the cavity and module as a larger system are discussed. These studies were performed after the RF design was finalised.

Coupler Port Blend Radius Studies

At the point where the coupler port meets the cavity, there is a join with a set 15 mm blend radius (R15), this radius in conjunction with changes in the cavity vessel led to stresses of up to 42 MPa on the coupler port joint as shown in Fig. 5. Increasing the blend radius reduced stresses, but due to space limitations this cannot be applied over the full region. Therefore, a variable radius was introduced with a fixed R15 in the horizontal plane and an increased value (R20-R30) in the region of peak stress.

Table 1 shows the results from these simulations. Increased blend radius significantly affects the stresses in this region but has a minimal affect on the Q_{ext} response, beyond a slight reduction in the range of Q_{ext} values achievable. This reduction in the range of values remains constant for increasing radii, thus this effect comes not from the blend radius but from the asymmetry created.

The main affect observed on the coupling response is a slight shift of the tip position range that corresponds to the optimal Q_{ext} values. This shift means the desired response occurs further out of the cavity. This is a desirable side effect as a shorter coupler antennae tip will reduce both weight and the disruption to the cavity field. Therefore a variables

Content from this work may be used under the terms of the CC BY 4.0 licence (© 2022). Any distribution of this work must maintain attribution to the author(s), title of the work, publisher, and DOI

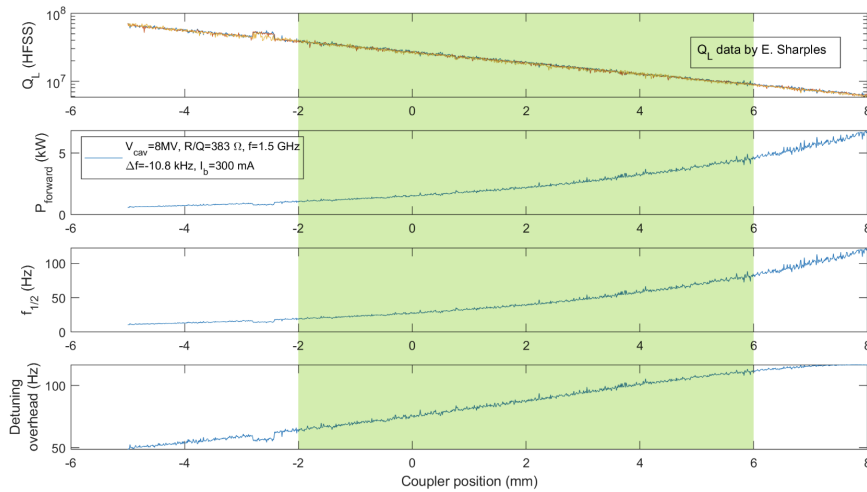

Figure 4: Plots comparing Q, power, and tuning overhead over the possible Q range of the coupler. The green box indicates the new Q range of the coupler.

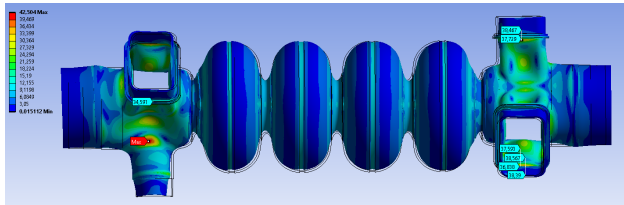

Figure 5: Initial design with R15 blend radius showing maximal stresses where the coupler port joined the cavity.

Table 1: A Table Showing How Changing the Blend Radius of the Coupler Port Changes the Stress and the Q_{ext} Response

| | R20 | R25 | R30 |
|--|----------------------|----------------------|----------------------|
| Stress (MPa) | 36 | 32.5 | 30 |
| Q_{ext} @ -4mm | 3.17×10 ⁷ | 3.1×10 ⁷ | 3.13×10 ⁷ |
| Q_{ext} @ 4mm | 8.01×10 ⁶ | 7.42×10 ⁶ | 7.19×10 ⁶ |
| Span | 2.37×10 ⁷ | 2.36×10 ⁷ | 2.41×10 ⁷ |
| Q_{ext}=3.86×10⁷ | -4.2 mm | -5.2 mm | -5.5 mm |
| Q_{ext}=9.16×10⁶ | 3.8 mm | 2.8 mm | 2.5 mm |
| Tip change | -0.2 mm | -1.2 mm | -1.5 mm |

radius of R30 is implemented in the cavity design, reducing stresses to 30 MPa and the coupler tip length by 1.5 mm to 334.4 mm, while maintaining the Q_{ext} range.

Displacement Studies

Since the coupler acts as a fixed point within the module, there will be some slight displacement of the coupler tip relative to the coax walls and cavity due to thermal contraction in the module during cool down. A maximum

displacement of 0.8 mm is expected. To see how this displacement affected the coupler Q_{ext} was calculated through simulation at different radial displacements as the tip moved in and out of the cavity, see Fig. 6. The definition of the positions can be seen in the insert of Fig 6, for example the position 90° is displaced by 0.8 mm in y and 45° is displaced by 0.56 mm in both y and Z, where x is the direction of mounting.

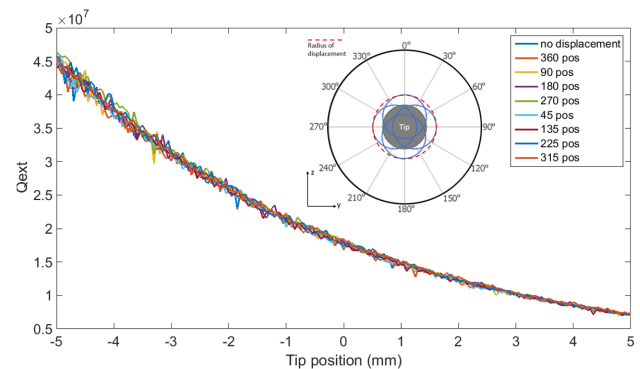

Figure 6: A plot of Q_{ext} vs tip position for the neutral and displaced tip positions. Tip was moved in 0.1 mm steps.

The Q_{ext} values of the displaced tip vary minimally from those of the non displaced tip. With the strongest deviation being when the coupler tip is furthest from the beam cavity axis. This behaviour could be due to the cut-off by the non coax tube part leading to smaller fields and thus a larger error (signal to noise) with a given meshing and Q_{ext} calculation. A comparison of the percentage difference between Q_{ext} of the coupler with and without displaced tip showed a deviation larger than 5% only for one case the 90° displacement when the coupler was furthest from the cavity. In general all results were lower than 10% and

hence acceptable. Thus provided the displacement remains at ≤ 0.8 mm the effect on the coupler is minimal.

COUPLER MANUFACTURING STATUS

Manufacturing of the 1.5 GHz VSR DEMO couplers by Research Instruments (RI) with Thales as a subcontractor began in September 2020. The prototypes are due to be delivered August 2021 with the series expected Q2 2022. Remote inspections of parts have occurred and inspections on site at the manufacture should be possible for the factory acceptance tests this July.

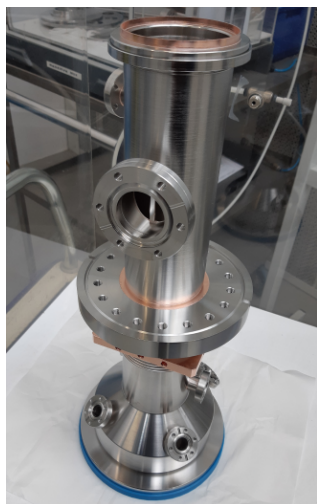

Figure 7: A one to one sample of the warm outer conductor ready for copper coating.

Thales is responsible for the manufacture, brazing and copper coating of the warm internal conductor (WIC), the warm external coax and the cold external conductor. The final qualification of the copper coating is ongoing, with the WIC already approved. Initial samples have been visually inspected at HZB and a tape adhesion test was performed. Thickness measurements will be taken from these samples and a protocol for sample processing developed for when the final copper coating samples reach HZB.

In parallel, Thales has begun to braze one to one samples and initial prototype pieces ready for final coating qualification. Figure 7 shows the one to one sample of the warm outer coax, including CF16 ports on the area around the cold window that were integrated initially for monitoring the cold window in testing but are now considered defunct. These ports will hold additional samples and will be used to further validate the copper coating.

RI are responsible for the manufacture of the cold inner conductor, the waveguide box and the ceramic windows including the E-beam welding and TiN coating. The final assembly, cleaning and heat treatment are also the responsibility of RI. All ceramics have been procured and heat treated, with a remote inspection before heat treatment and an in person inspection post heat treatment already passed. The warm and cold ceramics differ in dimensions

and so a sample of each type is required. Eight of each type were procured, these will then be used in the following way;

- 1 of each for samples
- 2 of each for the prototype couplers
- 4 of each for the series couplers
- 1 of each spare

After heat treatment of all ceramics one warm ceramic and one cold ceramic were identified for use as samples, these ceramics showed some discolouration on the surfaces and both had small scratches in the metallisation that could affect leak tightness. The samples have been brazed to their copper sleeves and then E-beam welded to an extended collar than can be used for pull tests. These samples were leak tested at RI and shipped to HZB for inspection in the form of a secondary leak test and a final pull test, which will be passed when the ceramic rather than the braze breaks.

TESTING AND CONDITIONING

Figure 8 shows the testing set up for the 1.5 GHz VSR demo couplers, comprising of a base copper RF testbox on which the couplers are mounted suspended within a vacuum vessel up to the 300 K flange to avoid condensation and icing on the parts. The system is cooled using gaseous Helium at around 90 K, with direct cooling on the base RF testbox and with thermal strips on the cold bellows of the coupler. The cooling pipes can be seen in red in Fig 8.

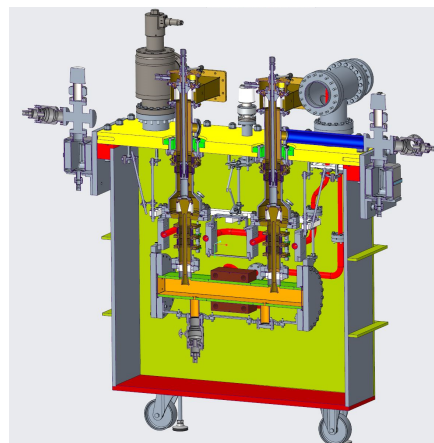

Figure 8: A cut through image of the testing set up showing both the base RF testbox and the vacuum vessel.

In addition to the gaseous helium cooling, the couplers will have compressed air cooling (CA in Fig. 9), which is used to cool the WIC and the warm window and cooling water (CW in Fig. 9) which cools the waveguide box. The testing set up is equipped with a large number of diagnostics to allow for careful monitoring of the set up during conditioning. In addition to the sensors shown in Fig. 9 temperature and flow rate sensors will be installed on the cooling medium and vacuum gauges to measure the vacuum levels.

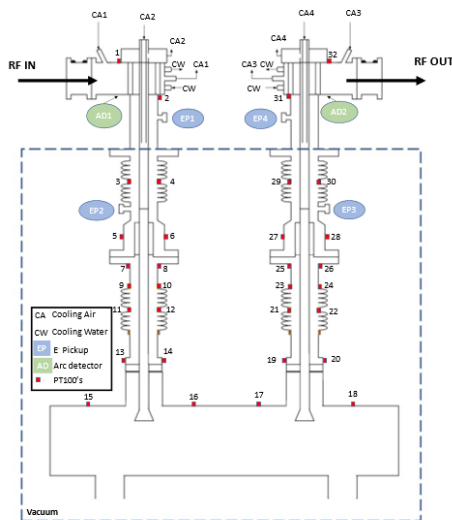

Figure 9: A sketch of the RF components of the test stand showing the locations of the sensors and cooling circuits.

The preliminary conditioning plan is based on the one used to condition the XFEL couplers [8], with the ramping down scheme used to condition the bERLinPro couplers at HZB [9] and is as follows;

1. Starting with a pulse length of 20 μ s at 50 Hz increase pulse power in steps up to 15 kW, maintain 15 kW power and then step back down.
2. Increase the pulse length to 30 μ s at 50 Hz and repeat the stepwise increase and decrease of power
3. Repeat for pulse lengths of 50 μ s, 100 μ s, 200 μ s, 400 μ s, 1 ms, 2 ms, 4 ms, 10 ms, 15 ms up to 20 ms (CW operation).

The size of the power steps will be determined during the conditioning depending on the response. The pulse length may be adjusted after the first run if it is found to be too long to notice events such as e pick up or Arc response. Once the desired power is reached at CW the coupler test stand will remain at this level for a prolonged period to enable the completion of conditioning. Conditioning is considered complete if both couplers operate for 8 hrs at 15 kW (± 1 kW) CW RF power under matched conditions (reflected power under 1%) after reaching thermal equilibrium and during this run,

- No vacuum events ($\geq 2 \times 10^{-8}$ mBar) in either coupler
- No temperature variation greater than ± 5 K of the equilibrium temperature excluding temperature variation caused by changes in the ambient temperature affecting cooling media.
- With no more than 3 interruptions caused by external factors, i.e., power loss, loss of cooling media etc.

Three coupler pairs have been ordered, one of which will be reserved as spares. If all prototype and series couplers

complete their conditioning, leaving the spare pair unused, an attempt will be made to condition up to a higher power of 50 kW.

CONCLUSION

Coupler manufacture is in full swing and component inspections both remotely and on site have been performed. Final inspections and factory acceptance tests are expected in the coming months, with the prototype couplers expected in late summer 2021 and series couplers in spring 2022. The initial set up for testing is planned in winter 2021 with the commissioning of the first coupler pair in early 2022. Tests with the cavities expected in early 2023. In preparation for this the testing plan is being finalised to ensure the best possible conditioning process can be found.

ACKNOWLEDGEMENTS

The authors would like to thank our invaluable external coupler consultant Wolf Dietrich Moeller for bringing his experience and expertise to the project, and Axel Neumann for his help with the Q studies and his insight into coupler conditioning.

REFERENCES

- [1] N. Wunderer *et al.*, "VSR DEMO Cold String: Recent developments and manufacturing status," presented at SRF'21, Grand Rapids, MI, USA, Jun. 2021, paper WEPTEV008, this conference.
- [2] F. Gloeckner *et al.*, "The VSR Demo Module design a spaceframe-based module for cavities with warm waveguide HOM absorbers," presented at SRF'21, Grand Rapids, MI, USA, Jun. 2021, paper MOPTEV013, this conference.
- [3] E. Sharples-Milne *et al.*, "Final design studies for the VSR DEMO 1.5 GHz coupler," in *Proc. IPAC'21*, Campinas, Brazil, May 2021, paper TUPAB343, p. 2261.
- [4] E. Sharples *et al.*, "Design development for the 1.5 GHz couplers for BESSY VSR," in *Proc. SRF'19*, Dresden, Germany, Jul. 2019, pp. 795-799. doi:10.18429/JACoW-SRF2019-WETEB9
- [5] V. Veshcherevich *et al.*, "High power tests of input couplers for Cornell ERL injector," in *Proc. SRF'07*, Beijing, China, Jul. 2007. doi:10.1109/PAC.2007.4441248
- [6] V. Veshcherevich *et al.*, "Design of high power input coupler for Cornell ERL injector cavities," in *Proc. SRF'05*, Cornell, NY, USA, Jul. 2005, paper THP54, pp. 590-592.
- [7] A. Tsakanian *et al.*, "Study of HOM power levels in the BESSY VSR module," in *Proc. IPAC'17*, Copenhagen, Denmark, May 2017, pp. 982-985. doi:10.18429/JACoW-IPAC2017-MOPVA052
- [8] W. Kaabi *et al.*, "Power couplers for XFEL," in *Proc. IPAC'13*, Shanghai, China, May 2013, pp. 2310-2312.
- [9] A. Neumann *et al.*, "RF Conditioning of 120 KW CW 1.3 GHz High Power Couplers for the bERLin Pro Energy Recovery Linac," presented at SRF'21, Grand Rapids, MI, USA, Jun. 2021, paper MOPTEV007, this conference.