

## Status of RF Superconductivity at Argonne National Laboratory

P.M. Markovich, K.W. Shepard, and G.P. Zinkann

Physics Division

Argonne National Laboratory

Argonne, Illinois 60439

### Introduction

This paper reports the status of hardware development for the linac portion of the Argonne tandem-linac accelerator system (ATLAS). The ATLAS superconducting linac consists of an independently-phased array of 45 superconducting niobium resonators of the split-ring type. The linac has been operating in its present form since 1985, on a 24 hours per day, 5 days per week schedule. The linac has in various configurations been delivering beam since 1978.[1]

An upgrade of the ATLAS system is currently under construction, the positive-ion injector (PII). The PII system will consist of an ECR positive-ion source mounted on a high-voltage platform injecting a very-low-velocity superconducting linac.[2,3,4] The completed system will provide for the acceleration of beams of mass up to uranium, and will replace the tandem electrostatic accelerator as the injector for ATLAS. The status of resonator development for the superconducting linac is reported in this paper.

Accelerating gradients in the existing ATLAS linac are currently limited by excessive heating and rf loss in the fast-tuning system associated with each superconducting resonator. Development of an upgraded fast-tuning system is also reported here.

### ATLAS Operation

The superconducting linac element of ATLAS continues to be a highly reliable operating element.[5] The accelerating gradients obtained on-line with the superconducting resonators continue to be somewhat below those obtained in off-line tests, which have been performed on all resonators and in which an average gradient of 4 MV/m has been achieved.

On-line gradients have averaged from 3 MV/m, typically obtained after maintenance, down to 2.2 MV/m, typically after prolonged operation without maintenance or high-field conditioning.

The necessity for re-conditioning arises primarily if any exposure to air occurs, either through vacuum accidents or substantial outgassing of nearby surfaces. We have occasionally observed beam-induced multipacting, which could be eliminated by conditioning in the presence of the heavy-ion beam.

## Fast Tuning System

Ambient vibration excites acoustic modes of superconducting cavities and, in the case of ATLAS resonators, causes rf eigenfrequency jitter of as much as 100 Hz peak-to-peak, or about 1 part in  $10^6$  in the 97 MHz resonators. The intrinsic bandwidth of the superconducting resonators is typically a few tenths of a hertz. Since beam-loading is small, typical beam currents being only a few particle nanoamperes, the loaded bandwidth of the cavities is at most a few hertz. Thus, direct control of rf phase is not possible without greatly over-coupling. Any fast-tuning system must handle an rf reactive power

$$P = 4 \Delta\omega U$$

where  $\Delta\omega$  is the tuning range (radians/sec) and  $U$  is the total rf energy content of the resonator. In ATLAS, the tuning system consists of a variable reactance (two state) in the form of a PIN diode switch, coupled to the resonant cavity sufficiently strongly to give the required tuning range. For a PIN diode tuning system, the reactive power  $P$  equals the product of the peak rf voltage across the diodes in the off state and the peak rf current through the diodes in the on state. For current ATLAS resonators, the reactive power requirement is typically 5 KVA.

Figure 1a shows schematically the fast tuning system originally developed for ATLAS.[6] Several key features should be noted. The fast tuner is operated at 77-90 K, is cooled by liquid nitrogen, and is thermally separate from the 4-5k superconducting resonant cavities. This is necessary since the rf losses in the tuner represent typically 95 percent of the total rf loss, which is roughly 100 watts per resonant cavity. A portion of the loss is caused by rf eddy-current heating of the capacitive coupling probe. The probe consists of several square cm of copper at 80-90k in an rf magnetic field (inside the superconducting resonator) of typically 45 Gauss. Another loss term of similar magnitude is the rf loss in the PIN diode active control element.

The coupling probe is cooled by thermal conduction through a beryllium oxide electrical insulator. The beryllium oxide insulator is joined by brazing to copper flanges at either end. These braze joints have proven unreliable: about 20% of 50 such units have failed mechanically, and a similar number, while apparently mechanically sound, exhibit impaired thermal conductivity, manifested by excessive heating of the capacitive coupling element during operation at high field levels. The probe tip temperature in the defective units becomes sufficiently high to heat the resonator by thermal radiation and to cause a thermal instability at the coupling port.

Figure 1b shows a new fast tuning system currently under development. Rf coupling is via an inductive loop, which can be cooled by conduction directly through copper. The electronic elements are cooled by immersion in liquid nitrogen. The required 77k, high-vacuum, rf feed-through is formed by a double indium gasket seal to a ring of high-density alumina. Also, a new PIN diode (Microwave Associates type MP4000) been employed, which provides an increase of more than a factor of two in reactive power capability.

Early tests of the new system have achieved phase stabilization of a superconducting H-type ( $\beta=0.105$ ) split-ring resonator at accelerating fields above 6 MV/m, and switched reactive rf power loads of more than 20 KVA, some four times greater than could be handled by the previous tuner design. The new tuner will be first used on the new PII linac, but would permit upgrading of the performance of the ATLAS linac.

### Status of the PII Superconducting Linac

#### Resonant Cavities

Figure 2 shows a cross section of the four geometries of superconducting resonant cavity required for the positive ion injector. The first three types, covering a velocity range  $.008c < v < .024c$ , operate at 48.5 MHz. The fourth type resonates at 72.75 MHz, and extends the velocity range to  $0.05c$ , sufficient to inject the existing ATLAS accelerator. The resonant cavities are all of the interdigital type, and consist of a four-accelerating-gap drift tube array terminating a coaxial, quarter-wave line.[2,3]

The technology used is a straightforward adaptation of that developed for the ATLAS split-ring resonators; a demountable rf joint is used to mount the counter drift-tube, and an explosively-bonded niobium-copper composite material is used for the resonator housing.[6]

Niobium prototypes of the first three interdigital resonator types have been constructed and tested. Figure 3 shows elements of the I3-class prototype prior to final welding and assembly. The tapered center conductor and drift-tube assembly are made of high thermal conductivity niobium.[7]

Figure 4 shows measured Q vs. accelerating field level at 4.2k for the three prototypes so far tested. In all cases the accelerating gradient substantially exceeds the initial, conservative performance projection of 3 MV/m.

All of the interdigital structures exhibit good mechanical stability. Static eigenfrequency shifts are typically 10 Hz at 1 MV/m gradient, and ambient noise induced vibration effects typically  $\leq 150$  Hz peak-to-peak.

### Linac Cryostat

Figure 5 shows a cross section of the cryostat for the injector linac. Each cryostat will house 6 resonant cavities and 3 or more superconducting solenoid lenses.

The cryostat is top-loading; the resonators and focusing solenoids are mounted on a rigid frame and aligned prior to insertion into the cryostat. A major change from the ATLAS cryogenic system is that static pool boiling is sufficient to cool the interdigital resonators, and forced-flow of liquid helium is not required.

### Future Plans

Development of superconducting components for the very-low-velocity injector linac is nearly complete. A prototype of the fourth interdigital resonator class, which operates at 72.75 HMz and a velocity of .037c, will be complete in early 1988. The first section of the injector linac will be completed in late 1988.

Although the performance of the ATLAS linac is satisfactory, performance can be improved by upgrading the fast-tuning system. Development of an improved fast tuner is nearing completion.

### Acknowledgements

We acknowledge many helpful discussions with Lowell M. Bollinger concerning all aspects of hardware development, and also note that Pat Den Hartog, in charge of ATLAS operation, deserves much of the credit for the good operating record of the system. This work was performed under the auspices of the U.S. Department of Energy, Nuclear Physics Division, under contract number W-31-109-ENG-38.

### References

1. J. Aron et al., in: Proc. 1984 Linear Accelerator Conf., Seeheim, FRG (May 7-11, 1984) Report GSI-84-11, p. 132, 1984.
2. L.M. Bollinger and K.W. Shepard, in: Proc. 1984 Linear Accelerator Conf., Seeheim, FRG (May 7-11, 1984) Report GSI-84-11 p. 217, 1984.
3. K.W. Shepard, in: Proc. of the 1987 Particle Accelerator Conf., to be published in IEEE Trans. Nucl. Sci.
4. R.C. Pardo and P.J. Billquist, to be published in Proc. of the International Conference on ECR Ion Sources and their Applications, East Lansing, Michigan (Nov. 16-18, 1987).
5. J. Aron et al., Rev. Sci. Instrum. 57, p. 737, 1986.
6. Proposal for ATLAS (Jan. 1978) and Addendum (Dec. 1978). Copies of these detailed discussions can be obtained from the Physics Division, Argonne National Laboratory.
7. P. Kneisel et al., IEEE Trans. Magnetics MAG-21, p. 1000, 1985.

(a)

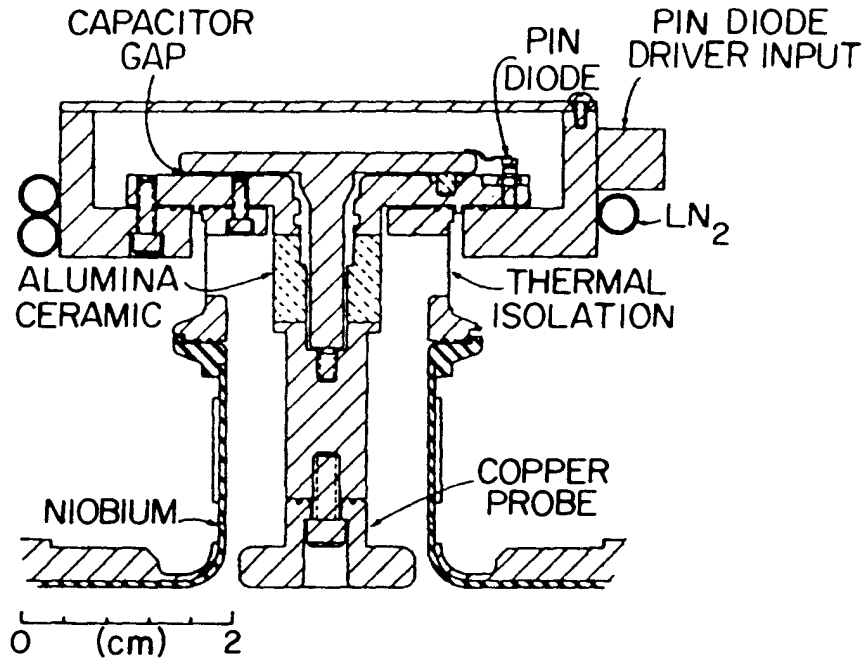

(b)

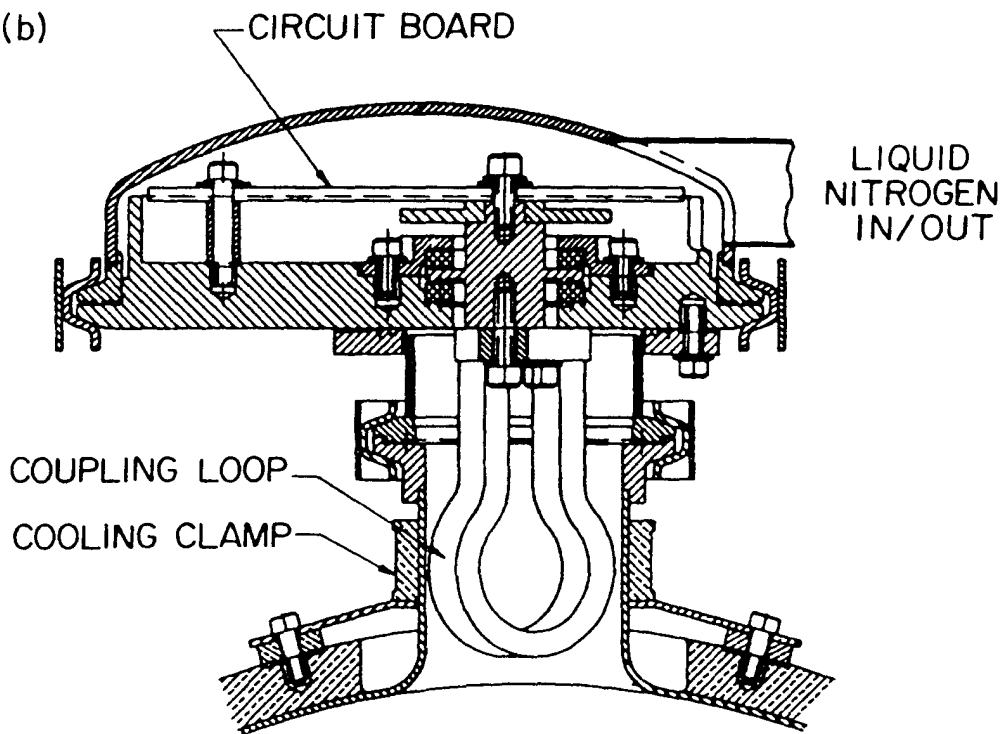

Figure 1. Two versions of the fast tuning system required to control the phase of ATLAS resonators. The first version (a) was capacitively coupled. Currently being developed is an inductively coupled version (b).

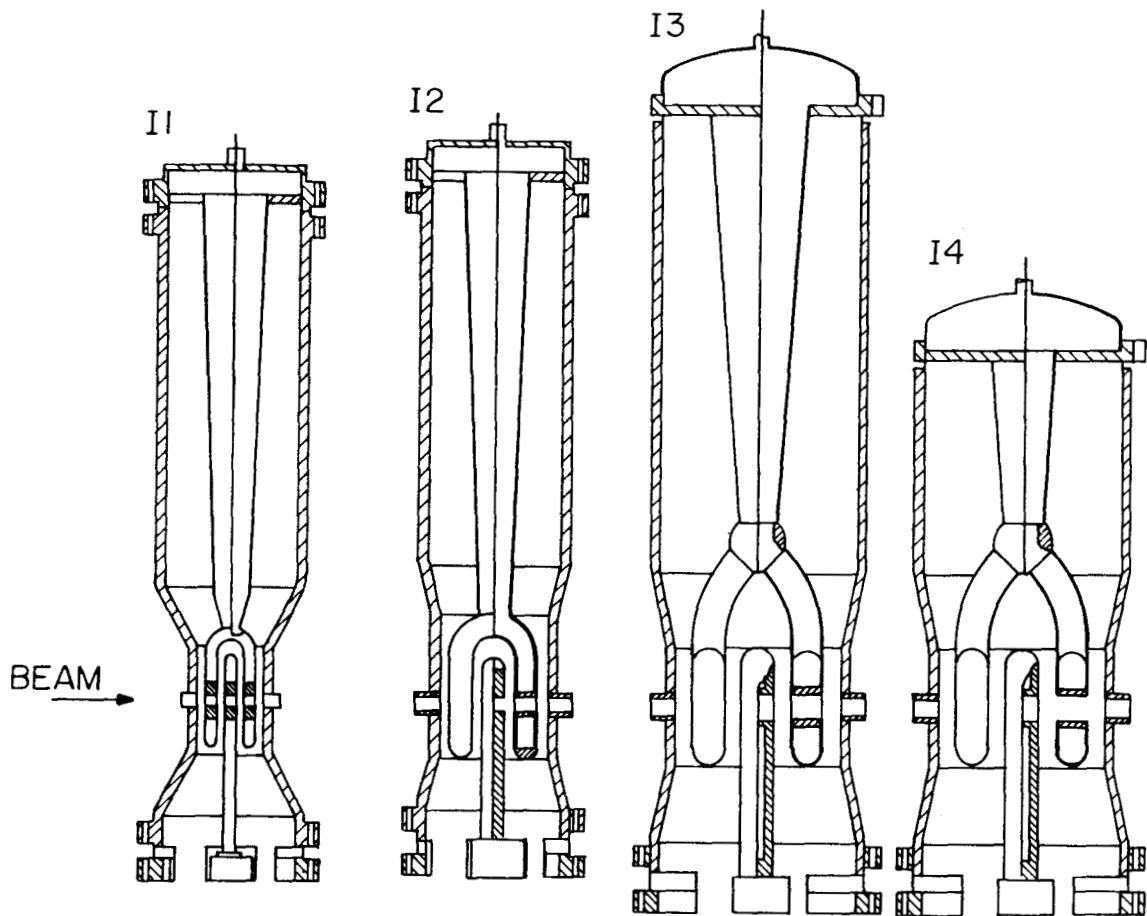

Figure 2. The four superconducting resonant cavities for a very-low-velocity heavy-ion injector linac. Types I1 - I3 operate at 48.5 MHz, and type I4 at 72.75 MHz. The four resonators cover a velocity range from below .008 to .05c.

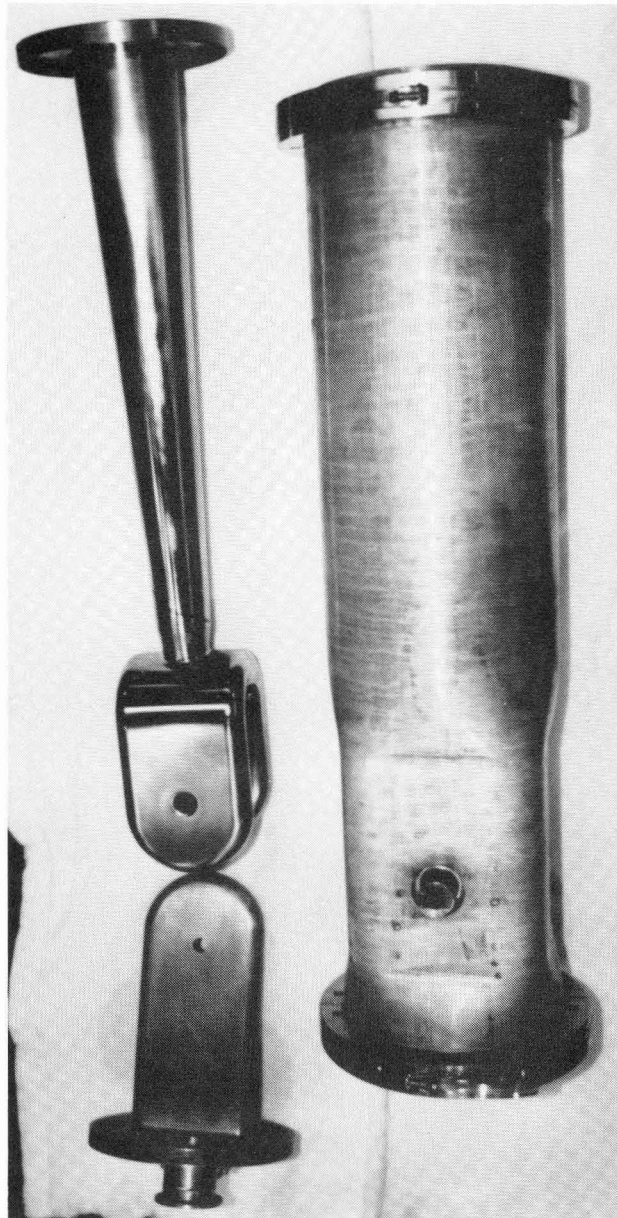

Figure 3. Elements of the prototype I3 resonator prior to final welding and assembly. Pieces shown include the explosively-bonded Nb-Cu outer housing, the high-purity niobium center conductor and forked drift-tube, and the demountably joined counter drift tube.



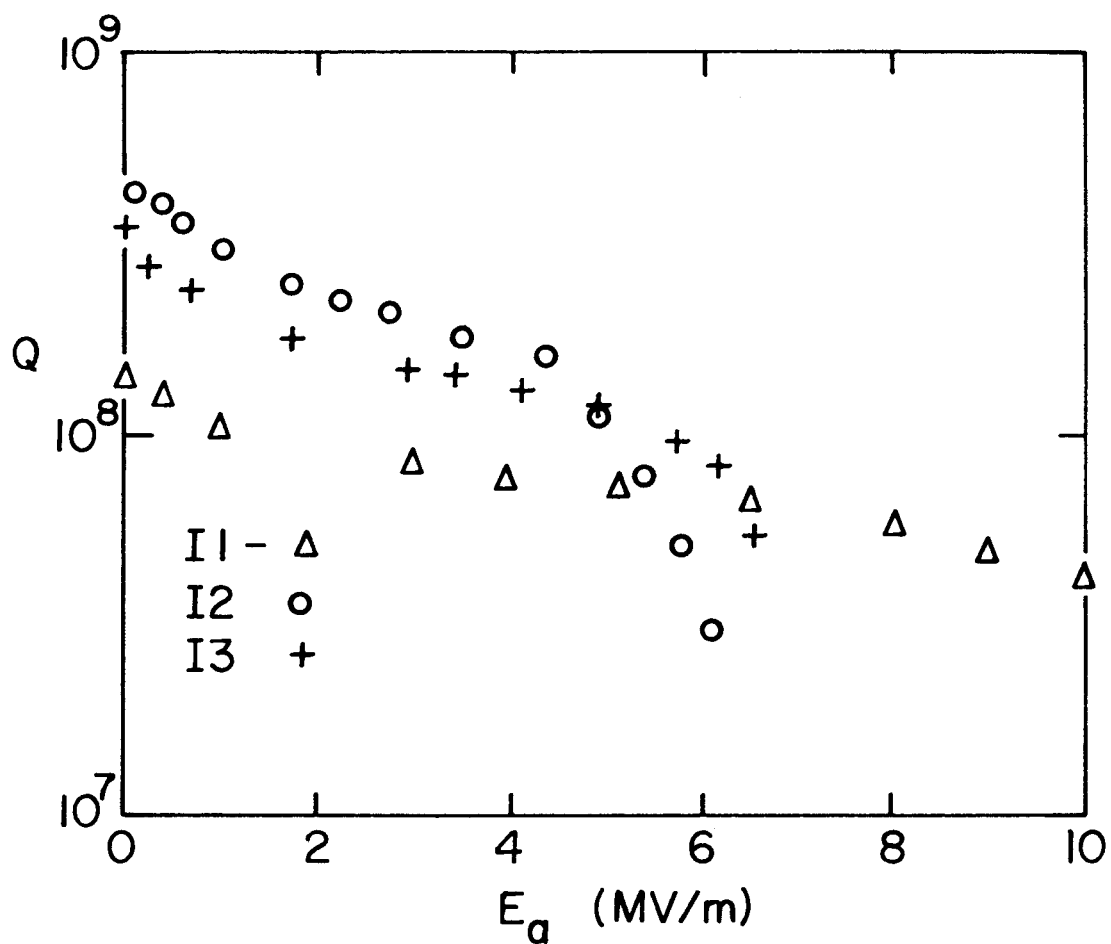

Figure 4. Performance obtained at 4.2K with prototypes of three classes of superconducting interdigital resonators.

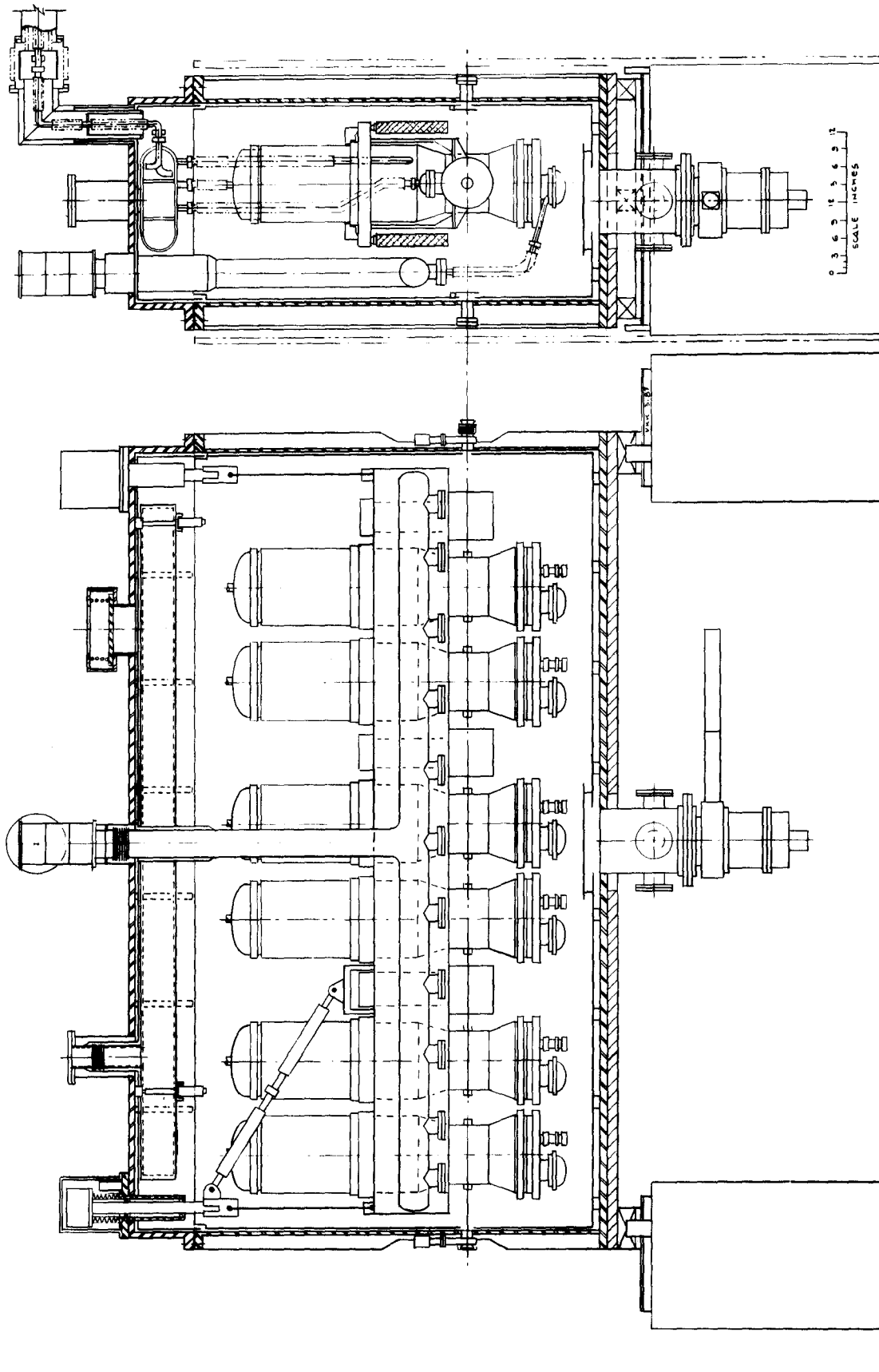

Figure 5. Cross-sections of one of three cryostats which will form the superconducting injector linac.